



GLOBAL
FINISHING
SOLUTIONS



Basic Non-Pressurized Control Panel

Operator Manual

Document Number: 239-066 rev 1

Read and keep this manual for future reference. All personnel operating the equipment described in this manual should review and understand all instructions before use.

Table of Contents

Introduction	3
About Global Finishing Solutions LLC	3
Contacting Global Finishing Solutions	3
Target audience	3
Conventions used in this manual	4
Safety notices	4
Information notices	4
General safety	5
Product safety	7
Basic Non-Pressurized control panel	8
Operating modes and controls	11
Using the booth	12
Starting the booth	12
<i>If applicable:</i> Manual balance setup	12
<i>If applicable:</i> Consta-Flow setup	13
<i>If applicable:</i> Economy mode	17
Shutting down the booth	18
<i>If applicable:</i> Air proving switch setup	18
<i>If applicable:</i> Dirty filter alert	19
<i>If applicable:</i> AMU interlock	21

Introduction

About Global Finishing Solutions LLC

Leading the Industry in Paint Booth and Finishing System Technology

With decades of experience, Global Finishing Solutions is the leading manufacturer of paint booths and finishing systems for many industries, including automotive refinish, aerospace and defense, industrial manufacturing, woodworking, and large equipment. By combining high-quality components, strong relationships with paint manufacturers, and our experienced distribution network, GFS provides the best equipment and support to set your business up for success.

Contacting Global Finishing Solutions

General information

- Toll-free: 800-848-8738
- Fax: 715-597-2193
- Email: info@globalfinishing.com
- Online: www.globalfinishing.com

Technical support

- Toll-free: 800-848-8738; select option 8
- Fax: 715-597-8818
- Email: techservices@globalfinishing.com

Parts and filters

- Toll-free: 800-848-8738; select option 2
- Fax: 888-338-4584
- Email: parts@globalfinishing.com

Target audience

This document is intended for use by trained, experienced paint booth installers and maintenance technicians. If you have questions about the installation procedure described in this manual, contact GFS as described above.

Conventions used in this manual

This section describes how information is presented, organized, and referenced within this manual.

Safety notices

This manual uses the following standards to identify conditions related to safety hazards and equipment damage.

Table 1. Safety notices

Symbol	Description
DANGER	Indicates an imminent hazard that will result in death.
WARNING	Indicates a hazard that can result in serious personal injury or death.
CAUTION	Indicates a hazard that can result in personal injury.
NOTICE	Indicates a situation that can result in equipment or property damage, but poses no risk of personal injury.

Information notices

In addition to the safety notices described above, this manual uses a boldface keyword to identify certain other types of information.

Table 2. Information notices

Keyword	Description
NOTE	Denotes general information that provides additional context or guidance.
Important	Denotes information to which you should pay special attention.
Reference	Directs you to related content in a separate document.
Prerequisites	Specifies other tasks that must be completed or conditions that must exist before you perform the current task.
Scope	Describes limitations to the current task or conditions under which the task applies or does not apply to the procedure.

General safety

Follow all safety guidelines when assembling, operating, or servicing this product.

WARNING

There are inherent hazards associated with the operation and service of this equipment. For your personal safety, observe all safety information. Failure to observe these safety practices can result in personal injury or death.

WARNING

Operation and maintenance of this product must be performed properly by qualified personnel who observe the warnings in all documentation and notes provided with and on the product.

WARNING

Follow all general standards for installation and safety for work on installations. Follow all good practices for the proper use of lifting tackle and equipment. The use of protective equipment such as safety goggles and protective footwear must be considered.

WARNING

All persons who will operate, service, inspect, or otherwise handle this product must read and understand the safe operating practices, safety precautions, and warning messages in this documentation.

WARNING

Comply with OSHA guidelines and with all applicable local electrical, safety, and fire codes and standards.

WARNING

All field wiring provided must comply with local codes or, in the absence of local codes, the National Electrical Code (NFPA 70). Article 516 covers applicable of flammable and combustible materials.

WARNING

Electrical installation should be completed by a qualified electrician. Installation must meet all applicable national, state, and local electrical codes.

WARNING

Ensure that all electrical components are grounded to a central ground.

WARNING

Disconnect and lock out the main electrical service before installing, adjusting, or servicing the product.

WARNING

Guards and covers that prevent contact with electrically energized or moving parts are required and must not be removed or left open during operation.

WARNING

Local fire and building codes require fire protection. Check with local inspector authorities for requirements.

CAUTION

Read and save these instructions before attempting to assemble, install, operate, or maintain the product described. Protect yourself and others by observing all safety information. Failure to comply with instructions could result in personal injury and/or property damage. Retain these instructions for future reference.

CAUTION

This manual contains statements that relate to worker safety. Read this manual thoroughly and comply as directed. Operate this equipment in accordance with the guidelines set forth in this manual. It is impossible to list all potential hazards of this equipment. Instruct all personnel involved with this equipment in the safe conduct and operation of the system. GFS recommends that only qualified personnel operate and maintain this equipment.

CAUTION

Safety signs, panels, and labels that are normally affixed to the product must be replaced immediately if illegible or missing.

CAUTION

New or replacement parts that are installed during repair or maintenance must include all safety signs, panels, and labels as specified by the manufacturer. These must be affixed to the new or replacement parts as specified by the manufacturer.

CAUTION

Where applicable, use earplugs or take other safety measures for hearing protection.

NOTICE

The product must be installed and serviced only by a trained, qualified service technician. Incorrect installation may void the warranty.

NOTICE

If you have questions about the warranty, please contact your distributor prior to contacting GFS.

Product safety

For both safety information, refer to the documentation that accompanied your equipment.

Basic Non-Pressurized control panel

The Basic Non-Pressurized (BNP) control panel provides pushbuttons and lights for operating booth's that are not pressurized by an Air Make-Up Unit (AMU) or intake fan. The BNP control panel also monitors system safety and performance.

There are three versions of the BNP control panel:

- BNP control panel
- BNP control panel with manual balance
- BNP control panel with Consta-Flow

NOTE

The BNP control panel is available for single or three phase power circuits and all standard North American voltages. Custom voltages are available.

The BNP control panel is mounted on the outside of the booth or on a nearby wall in a convenient position for the operator.



Figure 1. BNP control panel



Figure 2. BNP control panel on a booth with manual balance



Figure 3. BNP control panel on a booth with Consta-Flow

Operating modes and controls

The front of the Basic Non-Pressurized control panel provides the following controls:

NOTE

Some of these controls are optional and may not be present on every control panel.

Table 3. Basic Non-Pressurized Control Panel

Name	Description
Main Power Disconnect	Provides a means to disconnect power, along with the ability to add lockout/tagout safety devices.
Booth Lighting On/Off	Two-position selector switch that operates the paint booth lights.
System Start Pushbutton	Starts the exhaust ventilation.
System Stop Pushbutton	Stops the exhaust ventilation.
System Energized Light	Indicates that the system is energized when lit.
Exhaust Unit On Light	Indicates that the exhaust fan is operating when lit.
Fire System Fault	Indicates a fire protection system fault or alarm when lit.
Keypad with Dial	<i>If applicable:</i> Used to set the airflow in booths with manual balance.
Airflow Controller	<i>If applicable:</i> Pressure gauge with setpoint needles used for setting airflow in booths with Consta-Flow systems.
Dirty Filter Light	<i>If applicable:</i> Indicates that filters are loaded and air solenoid valve is disabled.

Using the booth

This section describes how to use a booth that has Basic Non-Pressurized controls.

Starting the booth

Perform the following steps to apply power to the booth:

1. At the control panel, turn the **Booth Lighting On/Off** selector switch to the on position to turn on the booth lights.
2. Press the **Start Pushbutton** to turn on the exhaust ventilation, initiating the booth.

NOTE

If the booth includes the optional AMU interlock, see “*If applicable: AMU interlock*” (page 21) for more information.

The exhaust fan is running. If all safety interlocks are met, the spray permissive signal will be active. Typically, a compressed air solenoid valve is also active, supplying process air to the spray gun.

If applicable: Manual balance setup

- Clean filters must be installed in the booth.
- A part or vehicle must be in the booth, simulating a typical spraying environment.

NOTE

The equipment to do a test spray or a velometer are required to test the airflow and properly set up manual balance.

Basic Non-Pressurized control panels equipped with optional manual balance systems have a keypad with a dial that controls the variable frequency drive (VFD). You can use the keypad and dial to manually increase the fan frequency as the filters load.



Figure 4. Manual balance keypad

Perform the steps below to configure manual balance:

1. Use the keypad and dial to set the fan frequency.

NOTE

The recommended starting point for the fan frequency is 54 Hz.

2. Press the **Set** button.
3. Test the booth's airflow:
 - Enter the booth and do a test spray to ensure that the paint is pulled to the exhaust filters.
 - Enter the booth and use a velometer to test the airflow. Refer to your paint manufacturer's recommended airflow.
4. Repeat steps 1-3 to adjust the fan frequency until your booth reaches the desired airflow.
5. Record the clean-filter fan frequency in Hz.

NOTE

This is the setting that the VFD should be returned to every time the filters are replaced.

6. As the booth's filters begin to load, manually increase the VFD's Hz setting to maintain the desired airflow.

If applicable: Consta-Flow setup

- Clean filters must be installed in the booth.
- A part or vehicle must be in the booth, simulating a typical spraying environment.

NOTE

The equipment to do a test spray or a velometer are required to test the airflow and properly set up manual balance.

Basic Non-Pressurized control panels equipped with optional Consta-Flow systems (GFS part number CF-UNV) automatically adjust the fan speed and maintain consistent airflow, regardless of filter loading.

NOTE

The Consta-Flow system should be installed as shown in the following diagram.

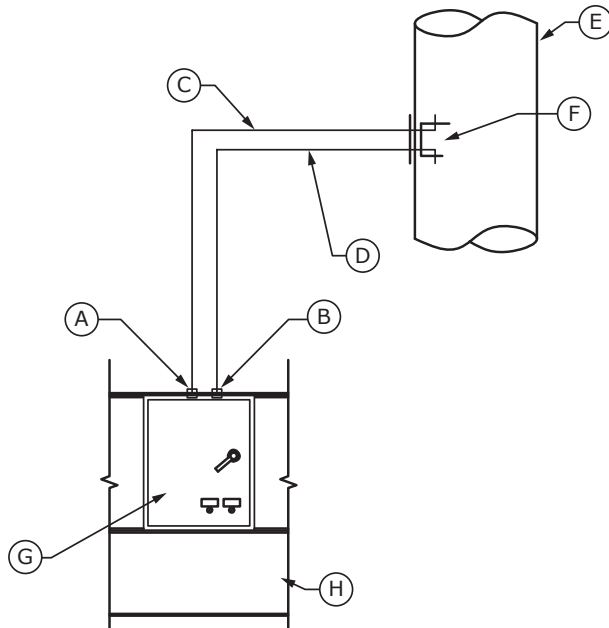

- A:** Low-pressure bulkhead fitting
- B:** High-pressure bulkhead fitting
- C:** Low-pressure sensing tube
- D:** High-pressure sensing tube
- E:** Exhaust stack
- F:** Consta-Flow System (CF-UNV)
- G:** Control panel
- H:** Outside booth (minimum 3 feet from any opening)

Perform the steps below to configure the Consta-Flow airflow controller (Photohelic):

1. With the booth off, ensure that the black indicator needle on the Photohelic is set to zero.
To adjust the indicator needle, use a small screwdriver to turn the zero adjustment screw.

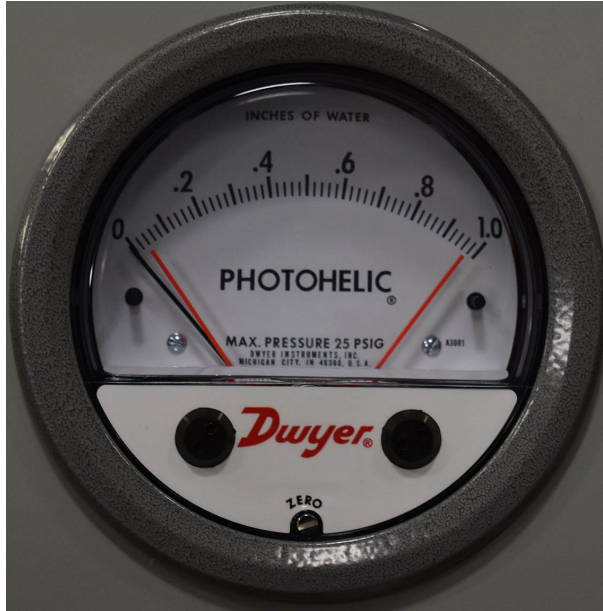

- Using the provided tool, twist the knobs on either side of the Photohelic so that the left-most orange needle is positioned all the way to the left and the right-most orange needle is positioned all the way to the right.



Figure 5. Photohelic adjustment tool

- Start the booth.
The VFD ramps the exhaust fan up and the black indicator needle moves into position between the two orange needles.
- Test the booth's airflow:
 - Enter the booth and do a test spray to ensure that the paint is pulled to the exhaust filters.
 - Enter the booth and use a velometer to test the airflow. Refer to your paint manufacturer's recommended airflow.
- If the airflow is acceptable, use the adjustment tool to move the orange needles to either side of the indicator needle, establishing the VFD setpoint.



6. If the airflow is unacceptable, use the adjustment tool to move the orange needles to the desired location. The indicator needle will adjust automatically to be within the setpoints.

NOTE

Move the orange needles lower on the Photohelic for less airflow in the booth and higher for more airflow.



The Consta-Flow system is now configured. The VFD will ramp the exhaust fan up or down to maintain consistent airflow.

If applicable: Economy mode

Basic Non-Pressurized control panels equipped with optional Economy mode will reduce the exhaust airflow to conserve energy when the spray gun is not in use. There are two options for Economy Mode activation:

- **Compressed airflow switch:** A flow switch mounted in the compressed air line senses the flow of compressed air to the spray gun. If airflow is not detected for the configured amount of time, the exhaust system enters Economy mode. When airflow is detected, Economy mode will be canceled.

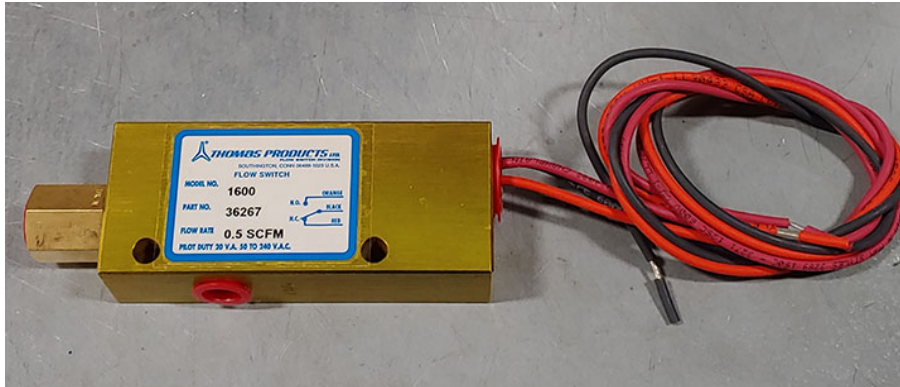

- **Gun hanger switch:** A hanger mounted on the side of the booth enables the spray gun to be hung up when not in use. This hanger is equipped with a switch that detects the presence of the spray gun. When the spray gun is on the hanger for the configured amount of time, the exhaust system enters Economy mode. When the spray gun is removed from the hanger, Economy mode will be canceled.



A timer in the control panel must be configured before Economy mode is activated. Set the desired time by rotating the dial so that the red indicator needle is at the desired time setting. The dial is configurable in minutes or seconds with a numerical time range of zero through ten.



Figure 6. Economy Mode switch

Shutting down the booth

Perform the following steps to shut down the booth:

1. Press the red **System Stop** pushbutton at the front of the control panel.
2. Switch off the **Booth Lighting On/Off** selector switch to turn off the booth lights.
3. Turn off the booth power at the Main Power Disconnect.

If applicable: Air proving switch setup

- The air solenoid valve must already be installed.
- Clean filters must be installed in the booth.

The optional air proving switch is part of the booth's ventilation system and is used to prove airflow across the exhaust fan. Loss of exhaust airflow causes the air solenoid valve to shut off, turning off spray air in the booth.



Figure 7. Air proving switch

NOTE

The desired mounting location of the switch is near the fan(s) being monitored. If necessary, the switch can be mounted remotely and a maximum of 50 feet of tubing can be used to connect the fan(s) to the switch.

Perform the steps below to configure the air proving switch:

1. Ensure that the ventilation system is in operation.
2. Remove the cover from the air proving switch and locate the adjustment screw. Carefully turn the screw until it is fully counterclockwise.
3. Slowly turn the adjustment screw clockwise until the switch trips.

NOTE

This can be observed by measuring the resistance across the common contacts using an electrical meter set to ohms. When the switch trips, the resistance will go to zero.

4. Carefully rotate the adjustment screw 1-1/2 turns counterclockwise from the trip point.

The air proving switch is now set.

If applicable: Dirty filter alert

- The air solenoid valve must already be installed.
- Clean filters must be installed in the booth.

The optional dirty filter alert will sense the differential pressure across the exhaust filters. When properly set up, this alert will light the dirty filter light and prevent any additional spraying if the differential pressure exceed the specification.



Figure 8. Differential pressure switch

Perform the steps below to configure the dirty filter alert:

1. In the junction box, carefully turn the differential pressure switch adjustment screw fully counterclockwise.

NOTE

A manometer or similar device should be used to adjust the switch correctly.

NOTE

Refer to the filter manufacturer's recommendations for filter loading. This example uses a typical paint arrest filter with a recommended loading of 1/2 inch wc pressure when clean to dirty. Actual filter loading values vary from filter manufacturers, material, and performance.

2. Start the ventilation system and note the differential pressure shown on the manometer or similar device.
3. Slowly add material (such as cardboard or plastic) over the exhaust filters to simulate filter loading. Cover the filter area until 1/2 inch wc is noted from the initial reading of the manometer.
4. Slowly turn the adjustment screw clockwise until the switch trips.

NOTE

This can be observed by measuring the resistance across the common contacts using an electrical meter set to ohms. When the switch trips, the resistance will go to zero.

The differential pressure switch is now set. The dirty filter alert will light when the filters are loaded and the spray solenoid will shut off.

If applicable: AMU interlock

The optional air make-up unit (AMU) interlock is a set of dry contacts that can be used to start the AMU when the booth is started. This interlock ensures that the exhaust and AMU supply fans run together.

NOTE

There will be a slight delay between booth start and when the AMU dampers open and the AMU starts.

NOTE

With an AMU interlock, there is a separate AMU remote operator station for visual operation and temperature selection.