

## RAPID UNITS - MC/OR

Training Manual



RAPID OR  
(Overhead Rail)



RAPID MC  
(Mobile Cart)

# CONTENTS

How it Works . . . . .	3
REVO Rapid Unit Diagram & Specifications . . . . .	4 - 5
Powering On . . . . .	6
Testing Rapid . . . . .	7 - 8
Overview . . . . .	9
Cassette Adjustment . . . . .	10
Using REVO Rapid Unit:	
Body Filler . . . . .	11
Etch Primer. . . . .	12
Primer Surfacer . . . . .	13
Basecoat . . . . .	14
Clearcoat . . . . .	15
Single Stage Paint . . . . .	16
Plastic Parts . . . . .	17
Specialty Programs. . . . .	18
Updates & Maintenance . . . . .	19
Parts Breakout . . . . .	20 - 23

## HOW IT WORKS

REVO Systems use short wave infrared light to cure coatings from the inside out. Traditional methods of curing use medium or long wave infrared. Medium and long wave infrared light cures from the outside in — which can trap solvents or only cure the surface — leaving coatings wet on the inside. Short wave differs from these other methods by penetrating the applied coating and heating the substrate beneath, forcing all of the solvents out and resulting in a uniform and complete cure. Since it works from the inside out, REVO can cure up to three full coats of a product in one curing cycle with no need to cure between coats. Additionally, the infrared technology works on nearly all substrates including steel, aluminum, fiberglass, plastic, carbon fiber, etc.

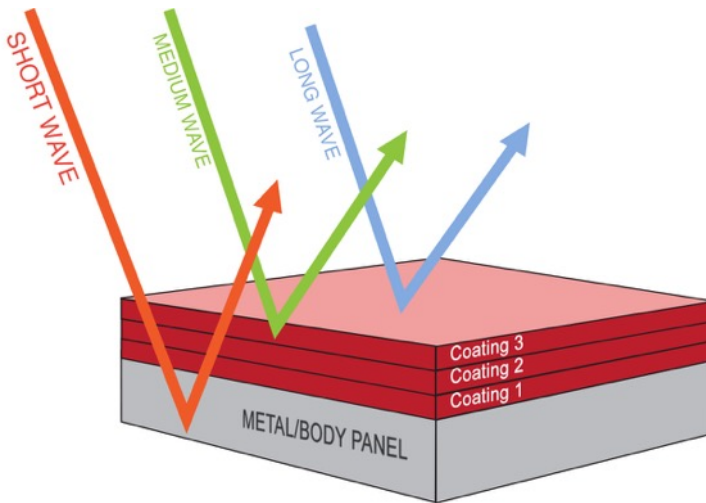

## RAIPD MC/OR DIAGRAM



## RAIPD MC/OR UNITS

SPECIFICATIONS	
Rated voltage	220-240 VAC, 3~/PE 480 VAC, 3~/PE
Auxiliary voltage	24 VDC
Rated frequency	50 – 60 Hz
Rated current	30 A 24 A
Rated power	6 kW + 6kW
Lamp type	Ruby infrared
Lamp output	1 KW / 2 KW
Drying temperature	Max 170°C / 338°F
Acoustic pressure level	70 dB(A) at 1 m distance
Sound power level	70 dB(A) at 1 m distance
Overall weight	about 110 Kg

# POWERING ON

First time Powering On the REVO Rapid Unit:

1. Flip the red main power switch to the on position to power the unit on and wait for it to boot up.
  - The unit is ready when you see this screen. Press the **Next** button to continue.
  - The “Select Program” screen appears.



2. From the “Select Program” screen, press the **Setup** button.



3. From the “Setup” screen, push the **Password** icon.



4. Enter the four-digit password on the “Password” screen, and then press **Enter**.
  - The password will vary depending on which version of software is in your unit. Passwords can be obtained from GFS or your distributor.

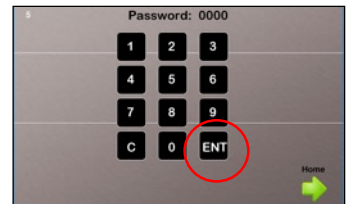

## TESTING - RAPID MC/OR

1. When you push the **Enter** button the screen will automatically enter into "Test mode." The first test is **lamp 1**. Verify that all four bulbs on lamp 1 are working. Press the **Up Arrow** icon to continue.



2. The next screen will be for **lamp 2**. Lamp 1 will shut off and all the bulbs on lamp 2 should power on. Verify they are working and press the **Up Arrow** icon to continue.



3. The next screen is for **ventola 1**. Verify that you are able to hear the fan power on in Cassette number 1.

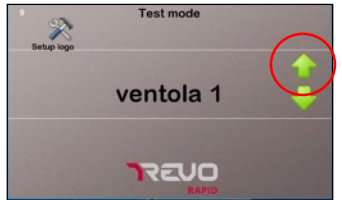

4. Press the **Up Arrow** icon and repeat for **ventola 2**.

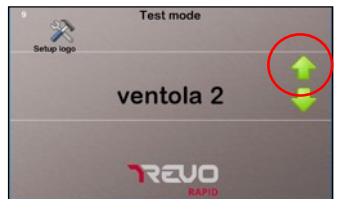

5. Press the **Up Arrow** icon again.

## TESTING - RAPID MC/OR

6. The next test will be for the laser aimers. Verify that the red lasers are turning on. Press the **Up Arrow** icon to continue.



7. The final test is for the sonar system. You will hear a high pitched tone to verify the sonar is working. Press the **Up Arrow** icon to continue.



8. If everything was working properly the **Test OK** screen appears. Press the **Next** button to exit.

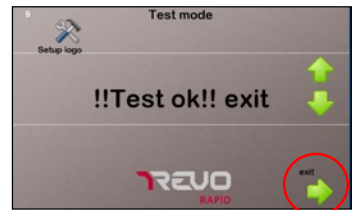



## OVERVIEW

### Using the REVO Rapid MC /OR Unit

- In order to use REVO on a top coating, all under coatings should also be cured with REVO before applying the top coat. If you don't use REVO to cure your primer, you shouldn't use REVO to cure your basecoat. If you don't use REVO to cure your basecoat, you shouldn't use REVO to cure your clearcoat.
- **Coverage Area:** Each cassette will cure a 40 inch by 40 inch area.
- **Incompatible Products:** 1K products are not intended to be heated and do not work well with REVO with the exception of basecoat. Basecoat works fine but avoid 1K putties and aerosol primers.  
**Mixing on a Scale:** All sprayable coatings should be mixed on a scale to ensure accurate ratios. Too much hardener will not speed up the curing process, it will only cause failure of the products.
- **No Accelerators:** Do not use any accelerators. REVO cures from the inside out and accelerators will skim the surface of the coating. When the REVO pushes out the solvents it can cause solvent popping.
- **Hardener and Reducer Selection:** Use only medium or slow hardeners and reducers. Fast hardeners will cause the same issues as accelerators.
- **Cure Times Are Adjustable:** The REVO comes with a decal that lists times and temperatures that are safe for a wide range of products. Contact GFS to get product specific recommendations. Some products can withstand greater temperatures and cure in shorter times.
- **Checking Temperature:** Infrared thermometers can give inaccurate readings due to the interference from the infrared light produced by the REVO. Check temperatures on the backside of the panel or in between flashes of infrared light.
- **Proper Shutdown:** Power the unit down by touching the power button on the touchscreen. When the computer shuts down then you can then flip the main power switch. Simply turning off the main power switch would be similar to unplugging your computer instead of shutting it down. This could lead to computer issues down the road.

## CASSETTE ADJUSTMENT

Side adjustment knobs are used to tilt the cassettes upward and downward.



The top adjustment knobs swing the cassettes out to the side.



The center knob articulates the cassettes clockwise and counter clockwise

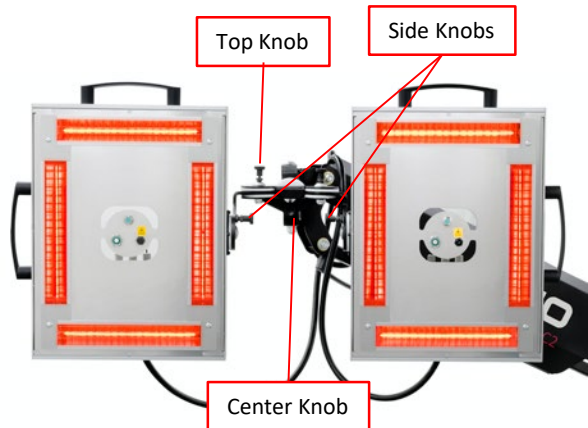

# BODY FILLER

Using the REVO Rapid Unit for Body Filler:

- Mix and apply the body filler.
  - Be sure to mix your body filler properly!** Many people put too much hardener in the filler. Follow the directions on the can. Too much hardener can cause pinholes or bubbling.
  - Automix filler systems are recommended to ensure mixing accuracy.
  - Always use two part fillers and putties. One part glazing putties and fillers are not compatible with REVO.
- Place Rapid unit about 2 feet away from the area to be cured.
- Select the **Body Filler** program and push the **Lamp Select** button (Picture 1).
- Select which lamp or lamps you will be using and press the **Drying Arrow** icon (Picture 2).
- The aiming lasers will turn on. Make sure they are aimed at the repair area and the cassette is parallel to the curing surface.
  - Position the cassettes 24 inches away from the repair area.
  - The **Place at 24 in** text will switch to say **OK** when the proper distance is achieved.
- Press the **Start** button and the Rapid unit will begin curing (Picture 3)
  - Curing will take place in two stages: The “Flash Off” mode will bring the panel to temperature and the “Drying” mode will finish the cure.
  - When the curing cycle is complete the lamps will automatically shut off.
- When the panel has returned to ambient temperature you can begin sanding the body filler.
  - Cooling can be accelerated by using a blow gun to force air over the panel.

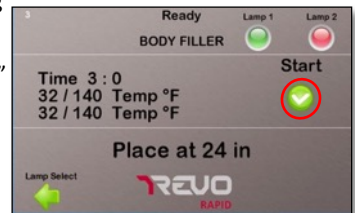
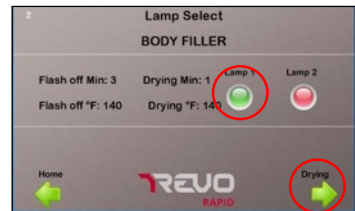
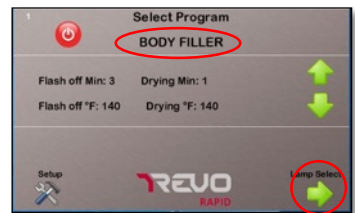

## ETCH PRIMER

Using the REVO Rapid Unit for Etch Primer:

- Mix and apply the etch primer.
  - Be sure to use a two-part etch primer.** 1K aerosol products are not meant to handle heat and do not having good etching qualities.
- Place the Rapid unit about 2 feet away from the area to be cured.
- Select the “Etch Primer” program and push **Lamp Select** button (Picture 1).
- Select which lamp or lamps you will be using and press the **Drying Arrow** icon (Picture 2).
- The aiming lasers will turn on. Be sure they are aimed at the repair area and the cassette is parallel to the curing surface.
  - Position the cassettes 24 inches away from the repair area.
  - The **Place at 24 in** text will switch to say **OK** when the proper distance is achieved.
- Press the **Start** icon and the Rapid unit will begin curing (Picture 3).
  - Curing will take place in two stages The “Flash Off” mode will bring the panel to temperature and the “Drying” mode will finish the cure.
  - When the curing cycle is complete the lamps will automatically shut off.
- When the panel has returned to ambient temperature you can begin applying topcoats.
  - Cooling can be accelerated by using a blow gun to force air over the panel.

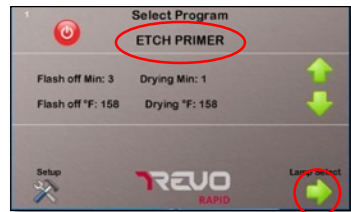

# PRIMER SURFACER

Using the REVO Rapid Unit for Primer Surfacers:

- Mix and apply the Primer Surfacers.
  - Always use slow or medium hardener and reducers. Do not use fast products.
  - Mix primer on the scale to ensure proper mixing.

2. Place Rapid unit about 2 feet away from the area to be cured.

3. Select the “Primer Surfacers” program and push the **Lamp Select Arrow** icon (Picture 1).



4. Select which lamp or lamps you will be using and press the **Drying Arrow** icon (Picture 2).

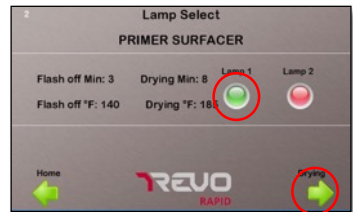

5. The aiming lasers will turn on. Be sure they are aimed at the repair area and the cassette is parallel to the curing surface.

- Position the cassettes 24 inches away from the repair area.
- The **Place at 24 in** text will switch to say **OK** when the proper distance is achieved.

6. Press the **Start** icon and the Rapid unit will begin curing (Picture 3)

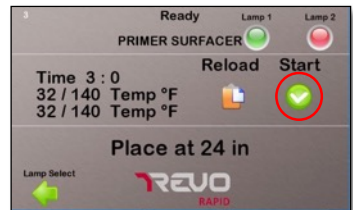

- Curing will take place in two stages The “Flash Off” mode will bring the panel to temperature and the “Drying” mode will finish the cure.
- When the curing cycle is complete the lamps will automatically shut off.

7. When the panel has returned to ambient temperature you can begin sanding the primer.

- Cooling can be accelerated by using a blow gun to force air over the panel.

8. If re-priming is needed after sanding, primer can be reapplied immediately and the same curing procedure should be followed.

## BASECOAT

Using the REVO Rapid Unit for Basecoat:

- Apply all coats of basecoat per manufacturer's recommendations.
  - There is no need to dry with REVO between coats.
  - For tri-coats: Dry with REVO after last coat of basecoat, and again after last coat of midcoat.
- Place Rapid unit about 2 feet away from the area to be dried.
- Select the "Base Coat" program and push the **Lamp Select Arrow** icon (Picture 1).
- Select which lamp or lamps you will be using and press the **Drying Arrow** icon (Picture 2).
- The aiming lasers will turn on. Be sure they are aimed at the repair area and the cassette is parallel to the drying surface.
  - Position the cassettes 24 inches away from the repair area.
  - The **Place at 24 in** text will switch to say **OK** when the proper distance is achieved.
- Press the **Start** icon and the Rapid unit will begin curing (Picture 3)
  - Drying will take place in two stages. The "Flash Off" mode will bring the panel to temperature and the "Drying" mode will finish the drying.
  - When the drying cycle is complete the lamps will automatically shut off.
- When the panel has returned to ambient temperature you can begin applying clearcoat.
  - Cooling can be accelerated by using a blow gun to force air over the panel.
  - If nibbing or any additional coats of base are needed, reapply basecoat and follow the same drying procedure.

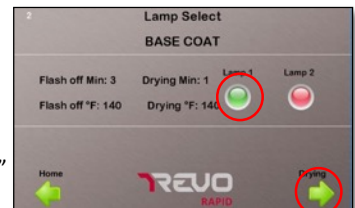
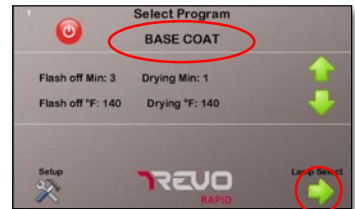

# CLEARCOAT

- Using the REVO Rapid Unit Clearcoat:
- Mix and apply all coats of clearcoat per manufacturers recommendations.
  - There is no need to cure with REVO between coats.
  - Only use slow or medium hardeners and reducers!**
  - Be sure to use a "Baking Clearcoat."** Air dry clears are not designed to handle heat and curing them with REVO could result in solvent popping or bubbling.
- Place Rapid unit about 2 feet away from the area to be cured.
- Select the "Clear Coat" program and push the **Lamp Select** button (Picture 1).
- Select which lamp or lamps you will be using and press the **Drying Arrow** icon (Picture 2).
- The aiming lasers will turn on. Be sure they are aimed at the repair area and the cassette is parallel to the curing surface.
  - Position the cassettes 24 inches away from the repair area.
  - The **Place at 24 in** text will switch to say **OK** when the proper distance is achieved.
- Press the **Start** button and the Rapid unit will begin curing (Picture 3)
  - Curing will take place in two stages The "Flash Off" mode will bring the panel to temperature and the "Drying" mode will finish the cure.
  - When the curing cycle is complete the lamps will automatically shut off.
- When the panel has returned to ambient temperature you can begin assembling parts or start the buffing process.
  - Cooling should not be accelerated, let it cool naturally.

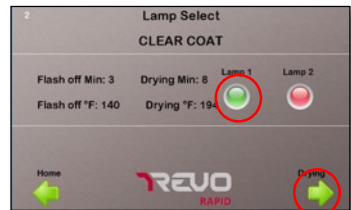

# SINGLE STAGE PAINT

Using the REVO Rapid Unit for Single Stage Paint:

1. Mix and apply all coats of the single stage paint per manufacturers recommendations.

- There is no need to cure with REVO between coats.
- **Only use slow or medium hardeners and reducers!**

2. Place Rapid unit about 2 feet away from the area to be cured.

3. Select the “Single Stage” program and push the **Lamp Select Arrow** icon (Picture 1).

4. Select which lamp or lamps you will be using and press the **Drying Arrow** icon (Picture 2).

5. The aiming lasers will turn on. Be sure they are aimed at the repair area and the cassette is parallel to the curing surface.

- Position the cassettes 24 inches away from the repair area.
- The **Place at 24 in** text will switch to say **OK** when the proper distance is achieved.

6. Press the “Start” icon and the Rapid unit will begin curing (Picture 3)

- Curing will take place in two stages The “Flash Off” mode will bring the panel to temperature and the “Drying” mode will finish the cure.
- When the curing cycle is complete the lamps will automatically shut off.

7. When the panel has returned to ambient temperature you can begin assembling parts or start the buffing process.

- Cooling should not be accelerated, let it cool naturally.

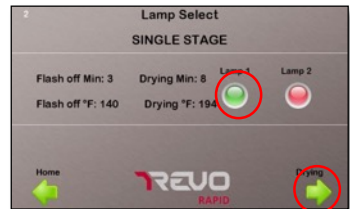



# PLASTIC PARTS

Using the REVO Rapid Unit for Plastic Parts:

- The plastic parts setting should be used on all coatings applied during a plastic repair process
  - This setting uses a lower temperature to cure as most plastic repair materials are more sensitive to higher temperatures.
  - Use this program after fillers, after primer, after basecoat and after clearcoat.
- Place Rapid unit about 2 feet away from the area to be cured.
- Select the “Plastic Parts” program and push the **Lamp Select Arrow** icon.
- Select which lamp or lamps you will be using and press the **Drying Arrow** icon.
- The aiming lasers will turn on. Be sure they are aimed at the repair area and the cassette is parallel to the curing surface.
  - Position the cassettes 24 inches away from the repair area.
  - The **Place at 24 in** text will switch to say **OK** when the proper distance is achieved.
- Press the **Start** button and the Rapid unit will begin curing.
  - Curing will take place in two stages The “Flash Off” mode will bring the panel to temperature and the “Drying” mode will finish the cure.
  - When the curing cycle is complete the lamps will automatically shut off.
- Follow all the curing and cooling procedures listed for the other programs for each coating you are curing. Just substitute the “Plastic Parts” program for the other program listed in that procedure.

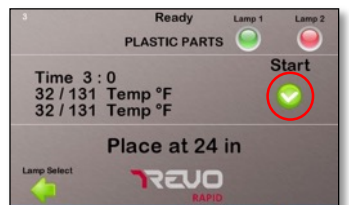

# SPECIALTY PROGRAMS

Using the REVO Rapid Unit for Specialty Programs:

- There are three specialty programs in the REVO Rapid Unit.
  - These can be programmed to cure a specialty product you are currently using in your shop. (Contact GFS for programming instructions)
    - A second type of clearcoat or primer
    - Plastic repair material
    - Seam sealers
    - Rock or chip guard
    - Decal removal



- Place Rapid unit about 2 feet away from the area to be cured.

- Select the desired specialty program and push **Lamp Select** button (Picture 1).

- Select which lamp or lamps you will be using and press the **Drying Arrow** icon (Picture 2).

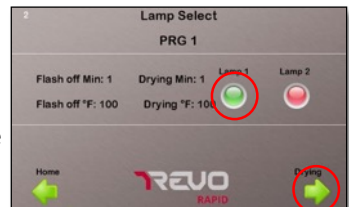

- The aiming lasers will turn on. Be sure they are aimed at the repair area and the cassette is parallel to the curing surface.
  - Position the cassettes 24 inches away from the repair area.
  - The **Place at 24 in** text will switch to say **OK** when the proper distance is achieved.



- Press the **Start** button and the Rapid unit will begin curing (Picture 3)

- Curing will take place in two stages The “Flash Off” mode will bring the panel to temperature and the “Drying” mode will finish the cure.
  - When the curing cycle is complete the lamps will automatically shut off.
- When the panel has returned to ambient temperature you can begin the next step of the repair process.
    - Cooling can be accelerated by using a blow gun to force air over the panel unless curing top coats.

# UPDATES & MAINTENANCE

## Updates

As new coatings products come to market and new software is developed the REVO unit may occasionally require a software update (similar to the way a phone or computer is updated). When an update is required GFS will send you an SD card that will need to be put into the computer of the REVO unit. The SD card will come with instructions on how to do so. These updates will keep the operating system running at optimal performance.

## Maintenance

### 1. Cleaning the bulbs and machine

- Touchscreen can be cleaned with mild detergents. Using screen protectors are recommended.
- Blow off bulbs with compressed air daily
- Mild solvents and detergents can also be used to clean bulbs of overspray when needed

### 2. Changing Bulbs

If a bulb is broken contact GFS or your distributor for replacement parts. They will provide instructions for changing a bulb (it is very simple)

### 3. Cleaning filters

Fan filters should be cleaned when dirty. They can be removed and blown off with compressed air or hand washed with soap and water (dry before re-installing)

### 4. Replacement Parts

Available from GFS or your local distributor, see parts breakout on the following page.

---

## NOTICE

Proper use and maintenance is critical to the function of REVO Systems. Ensure that all filters, parts, and components are clean and in good repair. Replace worn or damaged components immediately.

---

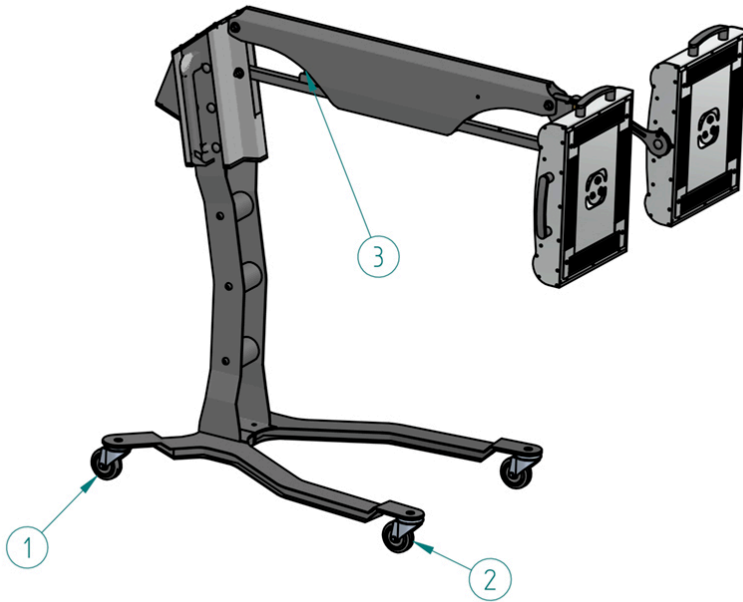

Position	Code	Description
1	8141343	WHEEL WITH BRAKE
2	8141426	WHEEL WITHOUT BRAKE
3	8006793	PISTON PANTOGRAPH

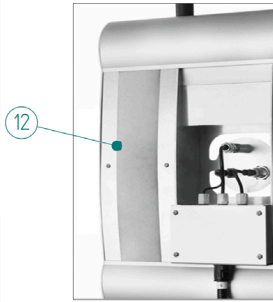
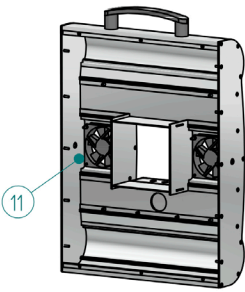
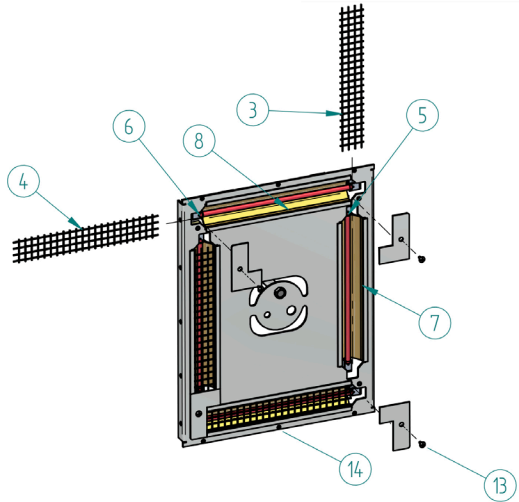
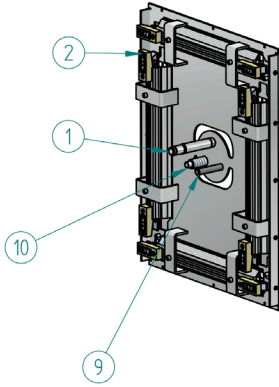

Position	Code	Description
1	352172	PYROMETER IR/FSU 242TBURST OUTPUT (FROM S.N.: 12.100.309 & 22.200.288)
1	337691	REVO PYROMETER IR/FSU 242T TC-K (TO S.N.: 12.100.308 & 22.200.287)
2	296350	REVO CERAMIC HOLDER FOR MET. FIXTURE
3	8147464	SAFETY NET 1K
4	8147530	SAFETY NET 2K
5	295824	LAMP IR 1KW RUBY ATT J
6	328641	LAMPIR 2KW RUBY ATT J
7	8136152	REFLECTIVE FOIL 1K
8	8136236	REFLECTIVE FOIL 2K
9	318337	LASER POINTER
10	328682	DISTANCE SENSOR
11	292813	REVO FAN 24VDC 92X92CM
12	8137226	FILTER FOR SPOT/RAPID UNITS
13	8115776	UNI7687 SCREW TCB 5X16 STANDARD
14	8113615	UNI7687 SCREW TPS 4.8 4X14 STANDARD

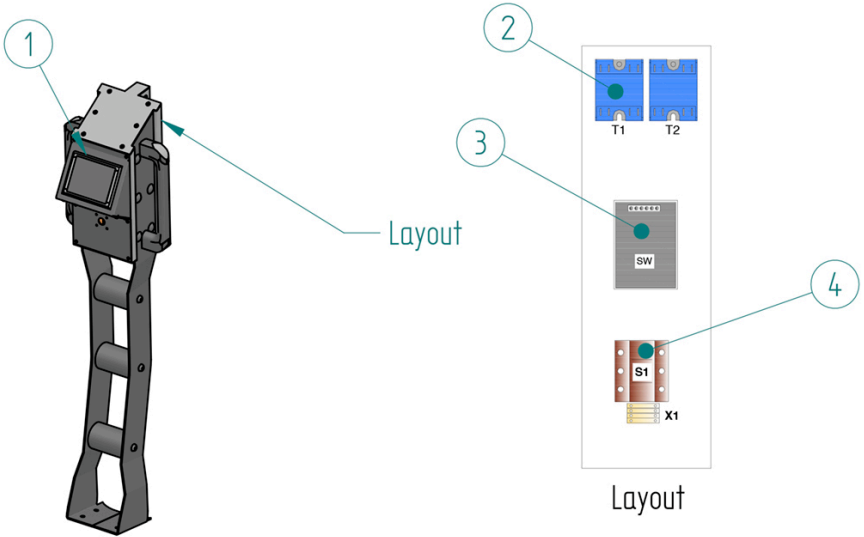

From S/N:

FSU 242 T 200V 22.200.226i  
 IR 242 T 200V 12.100.217i  
 IR 241 T 13.100.206i

have been used Celduc thyristor

Position	Code	Description
1	352182	VIDEO TOUCHSCREEN SERIAL PYROMETER (FROM S.N.: 12.100.309 & 22.200.288)
1	8179137	VIDEO TOUCHSCREEN TERMOCOUPLE PYROMETER (TO S.N.: 12.100.308 & 22.200.287)
2	8184996	THYRISTOR CELDUC 25A 400V
2	8185076	THYRISTOR CELDUC 25A 200V (MC2 only)
3	333666	SWITCHING SUPPLY VER. 200V (MC2 only)
3	8075426	SWITCHING SUPPLY VER. 400V
4	8021131	ON/OFF SUPPLY

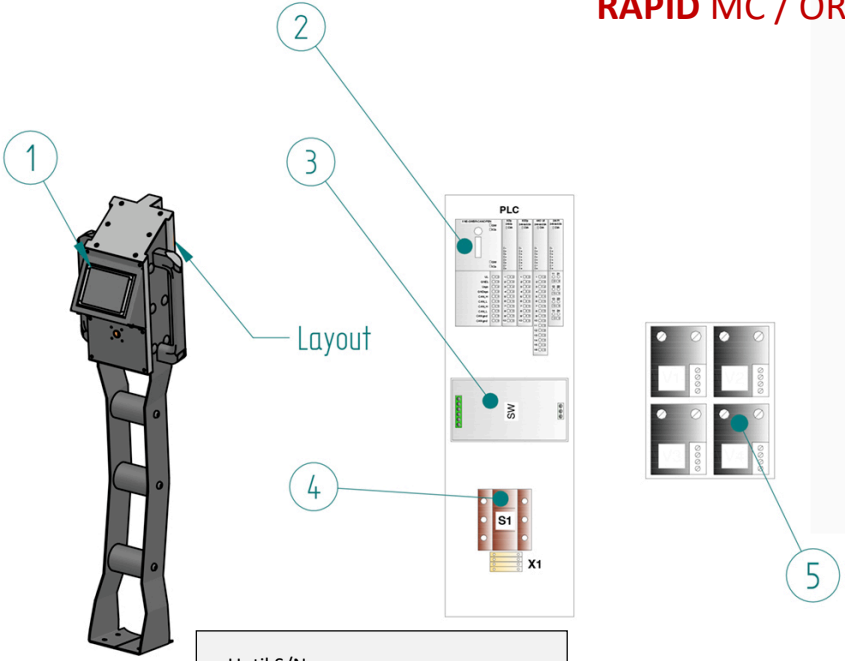

Until S/N:  
 FSU 242 T 400V 22..200.233i  
 FSU 242 T 200V 22.200.225i  
 IR 242 T 400V 12.100.214i  
 IR 242 T 200V 12.100.216i  
 IR 241 S 13.100.205i

have been used Crydon thyristor

Position	Code	Description
1	8102238	VIDEO HMI+PLC 5,7" TOUCH CANOPEN
2	8074924	MODULE PLC XNE 4AO
2	8074841	MODULE PLC XNE 8DI
2	8075269	MODULE PLC XNE 8DO
2	8074767	GATEWAY PLC XNE ECO CANOPEN
2	328831	BASE PLC XNE for THERMOCOUPLE
2	328823	MODULE PLC XNE 2AI THERMOCOUPLE
3	328849	SWITCHING SUPPLY VER. 200V
3	8075426	SWITCHING SUPPLY VER. 400V
4	8021131	ON/OFF SUPPLY
5	328724	THYRISTOR CRYDON 50A VER. 200V
5	MCME0006	THYRISTOR CRYDON 25A VER. 400V



**Faster Repairs. Better Results.**

[revocuring.com](http://revocuring.com)