

FINISHING EQUIPMENT FOR WOODWORKERS



GLOBAL
FINISHING
SOLUTIONS

FINISHING EQUIPMENT FOR **WOODWORKERS**

Global Finishing Solutions (GFS) provides a comprehensive line of paint booths and finishing equipment for the woodworking and wood manufacturing industries. Whether you are a small woodworking business or a large manufacturer, GFS has a wide range of equipment solutions to meet your wood finishing needs.

GFS Woodworking Paint Booths can accommodate all types of wood finishing coatings – including stains, varnishes, sealers, fillers, nitrocellulose, water-based lacquer and catalyzed lacquer. Choose from our pre-engineered booths and options, or work with our experienced design and engineering team to custom design a booth or system to meet your requirements.

WOOD FINISHING EQUIPMENT

DUST COLLECTION BOOTHS

The safest, most efficient option for prepping woodworking products prior to painting is a Dust Collection Booth. A controlled environment for prepping, Dust Collection Booths prevent dust from overtaking a shop, while providing excellent lighting. The addition of a Dust Collection Booth enables wood finishers to increase production and save on material costs by cutting rework. Dust Collection Booths from GFS are available in a range of sizes and price points to meet your budgetary needs.



OPEN FACE PAINT BOOTHS

For woodworkers wanting a safe, code-compliant environment for painting, Open Face Paint Booths offer flexible, cost-effective solutions that save valuable floor space and make it easy to move products in and out of the booth. Open Face Paint Booths are attractive to woodworkers because of the flexibility in their dimensions. Standard Open Face Paint Booths from GFS range from 6 to 20 feet wide, with depths as short as 6 or 8 feet. This allows products like cabinets to be stacked inside and easily accessible to the painter.



ENCLOSED FINISHING PAINT BOOTHS

Enclosed Finishing Booths provide the most stable, dependable environment for woodworkers. High-efficiency filtered doors prevent dirt and dust from entering the booth for cleaner paint jobs with less rework. If the Enclosed Finishing Booth is pressurized, the balanced airflow makes it easier to spray multiple colors in one cycle, allowing woodworkers to bundle products from different jobs. Enclosed Finishing Booths from GFS are available in 260 pre-engineered models and standard options or can be customized to meet your needs.



LOW-TEMPERATURE OVENS

Available in numerous sizes and different configurations, Low-Temperature Ovens – also known as Drying Enclosures – dry wood components by recirculating heated air. For woodworkers seeking increased throughput, a Low-Temperature Oven attached to a heated paint booth provides the highest return on investment. This allows you to maximize production, as you can easily move painted products into the oven, and while they are drying, you can paint, stain or coat another set of products in the booth. Low-Temperature Ovens from GFS can be added any time after the paint booth is installed, in sizes as small as a paint mix room to as large as a truck booth.

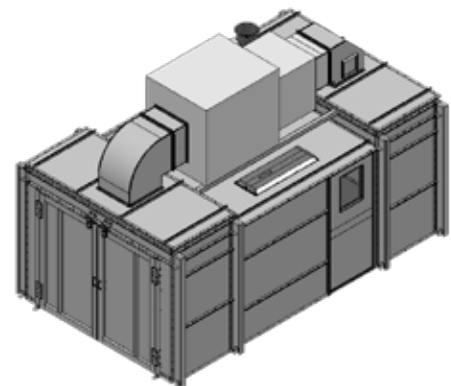

ENGINEERED SOLUTIONS. DEDICATED SUPPORT.

HIGH-QUALITY CONSTRUCTION

GFS Woodworking Paint Booths and finishing equipment are constructed from high-quality galvanized sheet steel. Quality components ensure longevity, safety and excellent structural integrity. GFS is experienced at designing and building state-of-the-art finishing equipment that exceed our customers' expectations. Woodworking businesses of all sizes continue to come back to GFS for consistent, quality equipment every time.

PRECISION ENGINEERED & BUILT TO LAST

Not just a sheet metal box, GFS Woodworking Paint Booths and finishing equipment are expertly designed and engineered for reliable performance and longevity. We guarantee quality by carefully selecting all equipment components and manufacturing or assembling a majority of these components in-house. Wall panels on GFS Woodworking Paint Booths are precision punched for rigid nut-and-bolt construction. Regardless of your production needs, you can count on your GFS equipment to deliver consistent results and last many years of use.

SERVICE & SUPPORT YOU CAN COUNT ON

We stand by our products and believe that excellent service shouldn't end at the sale. You can rely on GFS and our experienced distribution network for lifelong support and service of your woodworking equipment. GFS' unmatched Technical Services department and a local distributor are available to assist you with any emergency repairs or maintenance issues to ensure your equipment is always running in peak condition.

VARIETY OF MODELS & OPTIONS

GFS offers more than 500 pre-engineered models and multiple standard options for Woodworking Paint Booths. Pre-engineered models and standard options offer shorter lead times, having completed a thorough validation process to ensure consistent, quality performance. Standard options for GFS Woodworking Paint Booths include drive-thru configuration, six-tube lighting, pre-coated white panels for a brighter, cleaner appearance and Consta-Flow for consistent airflow, regardless of filter loading.

CUSTOM-ENGINEERED SOLUTIONS

What sets GFS apart from the rest is our ability to deliver precisely engineered custom products. We have the resources and expertise to design technologically advanced Woodworking Paint Booths and finishing equipment to meet your specific feature and size requirements. Custom options on GFS Woodworking Paint Booths include conveyor or crane slot openings, an Air Make-Up Unit (AMU), dual-skin insulated panels and custom product doors. Custom-engineered solutions provide the same exceptional quality and performance you expect from GFS in a truly one-of-a-kind booth for painting products and parts.

CODE-COMPLIANT FINISHING ENVIRONMENTS

GFS Woodworking Paint Booths and finishing equipment are designed to meet all applicable International Fire Code and NFPA codes. Our complete engineering staff includes structural, mechanical, electrical and code compliance experts to ensure that you can achieve all necessary permits and stamped drawings for your new equipment.

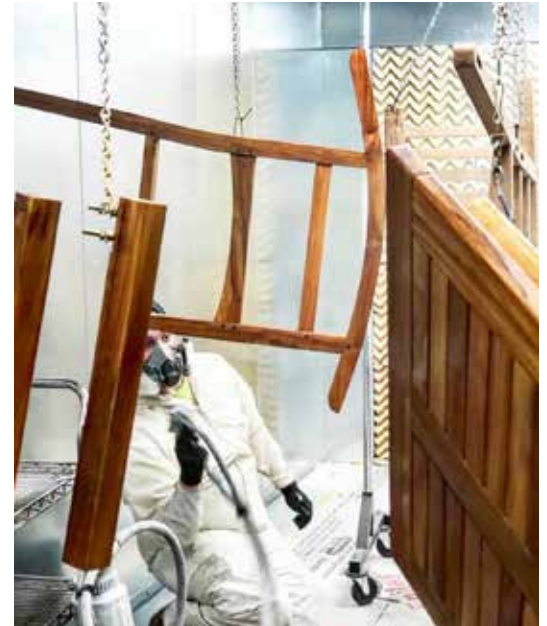

GLOBALFINISHING.COM

800-848-8738 • info@globalfinishing.com

© 2021 Global Finishing Solutions®. All Rights Reserved. • rev.07012021

