



GLOBAL
FINISHING
SOLUTIONS



Performer ES: Crossdraft and Semi-Downdraft Booths

Installation Manual

Document Number: 239-105 rev 2

Publication date 03/11/2022

Read and keep this manual for future reference. All personnel operating the equipment described in this manual should review and understand all instructions before use.

Table of Contents

Introduction	4
About Global Finishing Solutions LLC	4
Contacting Global Finishing Solutions	4
Target audience	4
Conventions used in this manual	5
Safety notices	5
Information notices	5
General safety	6
Booth safety	8
Booth description	11
Preparing for installation	12
Accepting delivery of your booth	12
Gathering required documentation	13
Confirming site requirements	14
Confirming booth layout	14
About the Design Drawings document	15
Page elements	15
Page types	17
Required materials	18
Required tools	18
Recommended equipment	19
Installation best practices	20
Unpack in stages	20
Sort parts by size	21
Follow assembly guidelines	22
Installation procedure	23
Prepare the floor	23
Build the rear bay	23
<i>If applicable:</i> Assemble a solid-back exhaust chamber bay	24
<i>If applicable:</i> Assemble a drive-through exhaust bridge chamber bay	24
Install the exhaust fan	25
Assemble the bays	26
Build a center bay	26
<i>If applicable:</i> Build the front bay in a crossdraft booth	28
<i>If applicable:</i> Build the front bay and front wall in a semi-downdraft booth	29
<i>If applicable:</i> Install the intake filter supports	30
Install the door frame for the front product door	31
Anchor the bays	31
Install a product door	32
Install the personnel door	34
Mount the door	34

Attach the handles	35
Install door seals	35
Assemble the exhaust stack	36
<i>If applicable:</i> Install the guy-wire kit	37
Install the lights	38
Install cage nuts in the light fixtures	38
Install light fixtures in panels	39
Install covers over light fixtures	41
<i>If applicable:</i> Install the manometer	41
Install the control panel	42
Install miscellaneous electrical devices	44
Install the air-proving switch for the exhaust stack	44
Install the air solenoid valve	45
Install the Economy Mode switch	46
Caulk the booth	46
Perform electrical hookup	47
Wire miscellaneous electrical devices	47
Install the access door in the exhaust plenum	47
Install filters	48
<i>If applicable:</i> Install the intake filters in a crossdraft booth	48
<i>If applicable:</i> Install the intake filters in a semi-downdraft booth	48
Install the exhaust filters	49
Perform commissioning and startup	51

Introduction

About Global Finishing Solutions LLC

Leading the Industry in Paint Booth and Finishing System Technology

With decades of experience, Global Finishing Solutions is the leading manufacturer of paint booths and finishing systems for many industries, including automotive refinish, aerospace and defense, industrial manufacturing, woodworking, and large equipment. By combining high-quality components, strong relationships with paint manufacturers, and our experienced distribution network, GFS provides the best equipment and support to set your business up for success.

Contacting Global Finishing Solutions

General information

- Toll-free: 800-848-8738
- Fax: 715-597-2193
- Email: info@globalfinishing.com
- Online: www.globalfinishing.com

Technical support

- Toll-free: 800-848-8738
- Fax: 715-597-8818
- Email: techservices@globalfinishing.com

Parts and filters

- Toll-free: 800-848-8738
- Fax: 888-338-4584
- Email: parts@globalfinishing.com

Target audience

This document is intended for use by trained, experienced paint booth installers and maintenance technicians. If you have questions about the installation procedure described in this manual, contact GFS as described above.

Conventions used in this manual

This section describes how information is presented, organized, and referenced within this manual.

Safety notices

This manual uses the following standards to identify conditions related to safety hazards and equipment damage.

Table 1. Safety notices

Symbol	Description
DANGER	Indicates an imminent hazard that will result in death.
WARNING	Indicates a hazard that can result in serious personal injury or death.
CAUTION	Indicates a hazard that can result in personal injury.
NOTICE	Indicates a situation that can result in equipment or property damage, but poses no risk of personal injury.

Information notices

In addition to the safety notices described above, this manual uses a boldface keyword to identify certain other types of information.

Table 2. Information notices

Keyword	Description
NOTE	Denotes general information that provides additional context or guidance.
Important	Denotes information to which you should pay special attention.
Reference	Directs you to related content in a separate document.
Prerequisites	Specifies other tasks that must be completed or conditions that must exist before you perform the current task.
Scope	Describes limitations to the current task or conditions under which the task applies or does not apply to the procedure.

General safety

Follow all safety guidelines when assembling, operating, or servicing this product.

WARNING

There are inherent hazards associated with the operation and service of this equipment. For your personal safety, observe all safety information. Failure to observe these safety practices can result in personal injury or death.

WARNING

Operation and maintenance of this product must be performed properly by qualified personnel who observe the warnings in all documentation and notes provided with and on the product.

WARNING

Follow all general standards for installation and safety for work on installations. Follow all good practices for the proper use of lifting tackle and equipment. The use of protective equipment such as safety goggles and protective footwear must be considered.

WARNING

All persons who will operate, service, inspect, or otherwise handle this product must read and understand the safe operating practices, safety precautions, and warning messages in this documentation.

WARNING

The roofs of GFS equipment are not designed or intended to be walked upon or to support weight of any kind. As designed and manufactured, equipment roofs do not meet the minimum requirements of a safe walking and/or working surface under OSHA 1910.22. Under no circumstances should the roof be used by maintenance personnel or others for walking, standing, or storage of any kind. When necessary, roof access should be secured through the use of a properly supported platform that satisfies the minimum load requirements specified by ASCE 7 (Minimum Design Loads and Associated Criteria for Buildings and Other Structures) and ASCE 37 (Design Loads on Structures during Construction). Additionally, personnel should always utilize appropriate fall safety protocols when using an elevated platform. Use of the roof in a contrary manner may result in injury and/or death.

WARNING

Comply with OSHA guidelines and with all applicable local electrical, safety, and fire codes and standards.

WARNING

All field wiring provided must comply with local codes or, in the absence of local codes, the National Electrical Code (NFPA 70). Article 516 covers applicable of flammable and combustible materials.

WARNING

Electrical installation should be completed by a qualified electrician. Installation must meet all applicable national, state, and local electrical codes.

WARNING

Ensure that all electrical components are grounded to a central ground.

WARNING

Disconnect and lock out the main electrical service before installing, adjusting, or servicing the product.

WARNING

Guards and covers that prevent contact with electrically energized or moving parts are required and must not be removed or left open during operation.

WARNING

Welding, cutting, and other spark-producing operations shall not be permitted in or adjacent to a booth until a written permit authorizing such work has been issued. The permit shall be issued by a person in authority following his or her inspection of the area to ensure that precautions have been taken and will be followed until the job is completed.

WARNING

Local fire and building codes require fire protection. Check with local inspector authorities for requirements.

CAUTION

Read and save these instructions before attempting to assemble, install, operate, or maintain the product described. Protect yourself and others by observing all safety information. Failure to comply with instructions could result in personal injury and/or property damage. Retain these instructions for future reference.

CAUTION

This manual contains statements that relate to worker safety. Read this manual thoroughly and comply as directed. Operate this equipment in accordance with the guidelines set forth in this manual. It is impossible to list all potential hazards of this equipment. Instruct all personnel involved with this equipment in the safe conduct and operation of the system. GFS recommends that only qualified personnel operate and maintain this equipment.

CAUTION

Safety signs, panels, and labels that are normally affixed to the product must be replaced immediately if illegible or missing.

CAUTION

New or replacement parts that are installed during repair or maintenance must include all safety signs, panels, and labels as specified by the manufacturer. These must be affixed to the new or replacement parts as specified by the manufacturer.

CAUTION

Where applicable, use earplugs or take other safety measures for hearing protection.

NOTICE

The product must be installed and serviced only by a trained, qualified service technician. Incorrect installation may void the warranty.

NOTICE

If you have questions about the warranty, please contact your distributor prior to contacting GFS.

Booth safety

DANGER

Ceiling panel load capacity for installation and maintenance: You must use temporary platforms that span at least two structural frames for maintenance. **Do not walk on or apply any pressure to lights or explosion (deflagration) relief panels.**

WARNING

All equipment must be operated and maintained in accordance with local, state, and federal (OSHA) requirements governing occupational safety, fire protection, and booth operations. Operators must read and understand GFS and included independent equipment and/or component manufacturer's instructions prior to use. **Disclaimer:** GFS is not responsible for any injury, illness, or property damage that results from not abiding by local, state, or federal (OSHA) requirements that govern occupational safety, fire protection, and booth operations. GFS is also not responsible for any injury, illness, or property damage that is the result of not adhering to GFS and/or independent equipment/component operating, service, maintenance, and/or installation requirement's or directives.

WARNING

Install the booth in compliance with locally enforced codes and standards.

WARNING

A fire suppression system is required by the International Fire Code and NFPA 33. A fire suppression system is not supplied with this booth.

WARNING

Do not allow overspray to accumulate on the inside of the paint booth walls. When overspray accumulates, remove it as soon as possible to prevent a possible fire hazard. Use a non-ferrous, non-sparking scraper to eliminate any possibilities of igniting combustible material.

WARNING

Do not leave piles of paint sweepings in the booth as it creates a possible fire hazard.

WARNING

Treat used filters and any other paint-contaminated items as flammable products and dispose of them safely.

WARNING

If coatings containing nitrocellulose are sprayed in the booth, all residue must be removed from exhaust diffuser components and all exhaust filters must be changed at least once a day.

WARNING

Improper disposal of used filters may cause spontaneous combustion. You must consult local authorities for proper storage and disposal requirements. Guidelines include:

- Immediately remove all contaminated filters from the paint booth.
- Discard filters to a safe, detached location, place them in a non-combustible container with tight-fitting lid, or place them in a water-filled metal container to prevent a possible fire hazard.
- Disposal varies depending on the type of paint that is being captured. Consult local authorities for storage and disposal requirements.

WARNING

Duct the exhaust air from the fan away from the working environment to the outdoors. Do not operate the booth unless exhaust has been ducted properly.

WARNING

Isolate the outdoor vent from air-conditioning intakes, windows, and any other equipment that may re-circulate the exhaust indoors.

WARNING

Turn on the exhaust fan before using the booth. Ensure that the exhaust fan is operating correctly before entering the booth.

WARNING

Check local codes to see if a booth interlock is required. A booth interlock prevents the spray devices from operating unless the exhaust fan is operating.

WARNING

Some spray activities may require the use of respiratory protection.

WARNING

Use an OSHA-approved paint spray respirator when spraying in the booth.

WARNING

Do not overfill the manometer. Overfilling allows fluid to collect in the flexible plastic connecting loop in the back of the manometer, which could cause a serious reading error. If the manometer is subject to overflow, make sure that the fluid has not passed into the plastic connecting loop.

WARNING

This equipment is designed for the removal of particulate matter only. Reduction of volatile organic compounds (VOCs) requires either coating reformulation or optional, additional equipment.

CAUTION

Become familiar with all controls before operating or servicing this booth.

CAUTION

Proper door alignment is critical to the operation of the booth. Ensure that there is equal space around the doors. Move the bottom of the door jamb to the left or right or in and out until the doors are sealed and plumb.

CAUTION

If this installation includes pumps or compressors, install and connect those devices in accordance with the manufacturer's documentation.

NOTICE

GFS recommends storing crates indoors pending installation. If you must store crates outside, protect crates and their contents from moisture to prevent damage to equipment.

NOTICE

Install the control panel per NFPA 70 and local codes and standards.

NOTICE

Failure to anchor the booth structure to the floor properly may result in structural damage.

Booth description

GFS' Performer ES provides value and reliable performance for shops in need of an affordable all-in-one paint environment. Performer ES booths feature single-skin, galvanized steel panels with non-pressurized crossdraft or semi-downdraft airflow.

Optionally, semi-downdraft booths may be pressurized with an intake fan or BTFD 1200 air heater.

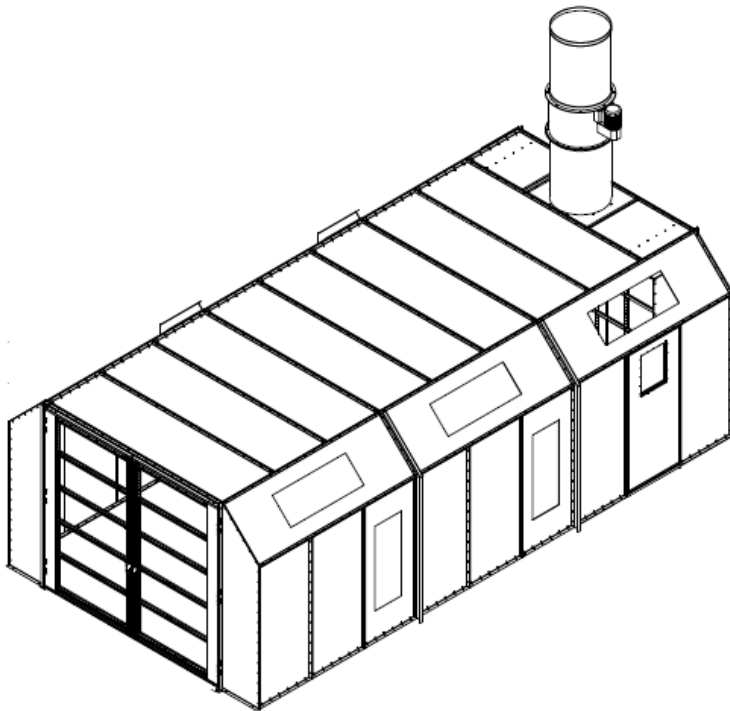

Figure 1. Crossdraft Performer ES booth

Preparing for installation

Accepting delivery of your booth

The booth is delivered unassembled, in multiple crates.

Upon delivery, count the number of crates you received and compare that number to the expected number per the Bill of Lading. Also inspect each crate for any signs of damage during shipment.

NOTE

If you see shipping damage, note it on the freight carrier's paperwork; failure to do so may result in claim denial.

If any parts are missing or damaged, contact Global Finishing Solutions at 800-848-8738 to speak to a Technical Service Representative.

NOTICE

GFS recommends storing crates indoors pending installation. If you must store crates outside, protect crates and their contents from moisture to prevent damage to equipment.

Gathering required documentation

Ensure that you can locate these documents and that they are available during the installation procedure.

NOTE

Certain manuals, project drawings, and the Job-Specific Guide are also provided electronically to distributors via box.com. Many manuals are available for download on globalfinishing.com.

Table 3. Additional documentation

Document	Description	How provided
Design Drawings	Provides instructions for assembling this particular booth and includes information about the booth order, configuration, and components.	Ships in the "Miscellaneous" box
Electrical Drawings	Provides wiring diagrams for electrical components.	Ships inside the control panel
<i>If applicable:</i> Air heater owner's manual	Installation, operation, and maintenance instructions for the air heater, if purchased.	Ships inside the air heater control panel
Final Commissioning Document (D0420)	Includes all tasks related to booth startup and commissioning.	Ships inside the control panel

Confirming site requirements

Before beginning the installation procedure, confirm that the site where the equipment will be assembled meets the following requirements:

- The floor where you will assemble the paint booth is level.
- There is sufficient overhead clearance for an exhaust unit and the exhaust ductwork in the area where the equipment is to be located.
- A licensed electrician has verified that the incoming power meets the requirements specified for the equipment. (The power specification is included with the submittal or provided at delivery.)
- The appropriate miscellaneous hardware kits are available on-site. (Either purchased from GFS with the equipment, or obtained elsewhere by the customer.)

Confirming booth layout

Before beginning the installation procedure, review the booth configuration and layout with the end user. Be sure you understand what options this booth includes and how the end user wants to arrange the booth.

The GA page of the Design Drawings shows one *possible* booth layout. However, end users might want their booths arranged differently. **During installation, you must make the appropriate adjustments to the instructions to accommodate the actual booth layout.**

For best results, review the GA page of the Design Drawings drawing with the end user and discuss the items listed below:

- Does this booth have an air heater?
- Is this booth a drive-through booth (a booth with a product door on each end) or a solid-back booth?
- Where does the end user want to locate the personnel door?
 - On the left or right side of booth?
 - At which panel position?
- Where does the end user want to place the control panel?

NOTE

Per NEC, the control panel cannot be located within 3 feet of any door opening. Refer to “Install the control panel” (page 42) for more information.

- On an exterior booth wall? (If so, specify which.)
- On a nearby wall? (If so, determine distance and orientation relative to booth.)
- Within the booth’s interior, how does the end user want to arrange the wall lights?
- If the booth includes standard options and accessories, where should those items be located? (Examples include additional light fixtures, rotating access tables, observation windows, parts hangers, additional personnel doors, etc.)

About the Design Drawings document

Page elements

Pages within the Design Drawings document contain the following elements:

- **Title block:** The title block is located along the right edge of each page. It contains the model information, drawing identification label or number, the order/serial number, and other information.
- **Model Info:** Contains text that identifies each page within the Design Drawings document, e.g., "Overall Assembly". When the installation instructions refer you to a specific page within the Design Drawings, look for that text in the Model Info field. (For a description of the various page types that might be included in your Design Drawings document, see "Page types" (page 17).)
- **Scale:** If the drawing is to scale, the scale is defined here (e.g., 3/16" = 1' 0"). Otherwise, this field contains "NTS," or "Not to Scale."
- **Drawings:** The main area of each page can contain any or all of these types of drawings:
 - An exploded and/or assembled view of the product or subassembly
 - Additional views or "Detail" drawings
- **Bill of Materials:** Any page that includes a drawing with labeled parts also includes a table that lists each item number with its corresponding part number and quantity.
- **Quantity per Booth:** Pages that show a subassembly of the product and list the quantity provided of that particular subassembly.
- **Notes:** Pages within the Design Drawings often contain notes that provide information about how to install that particular section or subassembly.

About the Design Drawings document

NOTE:

- USE BRUSH & 3/4" NUTS & WITTS FOR ALL TOP ANGLE AND PANEL CONNECTING.
- USE 20" x 4" x 1/2" GAL. SS/304 ANCHORS TO MOUNT PANELS TO CEILING. (IF OTHER)

DISCRETE AND INVENTORY BY:

PACKED BY:

QUANTITY PER BOOTH:

BOOTHS REQUIRED:

TOTAL QUANTITY:

ITEM	QTY	ITEM NUMBER	DESCRIPTION	MATERIAL
21	2	RF-0001-15110	PANEL, 36.000 x 108.000	18 GA
22	4	RF-0001-15110	PANEL, 36.000 x 40.000	18 GA
23	3	RF-0001-15110	PANEL, 36.000 x 114.000	18 GA
25	8	RF-0001-15110	TOP ANGLE, 3/4 x 1/2 x 1/8	18 GA
27	2	RF-0001-15110-001	WALL SUPPORT ANGLE, 30.000 x 112.000	14 GA
29	2	RF-0001-15110	PANEL, 36.000 x 81.000	18 GA

GLOBAL FINISHING SOLUTIONS
 1000 W. 10TH ST. SUITE 100
 OSCEOLA, WI 54758 USA
 800-948-8738
 globalfinishing.com

SCALE: 1/2" = 1'-0"
DATE: 11/25/2020
PROJECT: 11/25/2020
REVISION DATE:

PROJECT NO.: 10148011-11
PROJECT NAME: 11/25/2020

DESIGNED BY: [Redacted]
CHECKED BY: [Redacted]

DRAWING SET: [Redacted] **REVISION:** [Redacted]
ROLL: [Redacted] **DRAWING NO.:** [Redacted]

- A:** Serial number
- B:** Model info
- C:** Drawing number
- D:** Drawings: Main view (exploded and/or assembled)
- E:** Drawings: Detail view
- F:** Bill of materials
- G:** Quantity per booth
- H:** Notes
- I:** Title block

Page types

The Design Drawings document may contain any of the following pages that apply to your particular product.

Table 4. Page names in the Design Drawings document

Page name	Description
<i>If applicable:</i> Air Heater	Provides instructions for assembling the air heater.
<i>If applicable:</i> Air Heater Discharge Connection	Shows how to assemble the discharge hood that connects the optional air heater to the booth plenum. NOTE This page applies only to booths that have a BT air heater.
Booth Caulking Guide	Provides instructions for applying caulk to the booth.
End Section	Shows an exploded view of the exhaust yoke or exhaust chamber located at the rear of the booth.
<i>If applicable:</i> Filter Ceiling	Shows how to install the filter ceiling. NOTE This page applies only to semi-downdraft booths.
Front Section	Shows an exploded view of the front section (a bay that accepts a product door), hip light panels, and ceiling located at the front of the booth.
Label Placement Instructions	Shows where to place various booth labels, including exit, maintenance, and safety labels.
Mid Section	Shows an exploded view of the side walls, hip light panels, and ceiling located at the middle of the booth.
Overall Assembly	Shows an exploded view of the entire booth; identifies the major components and sub-assemblies of the booth.
<i>If applicable:</i> Product Doors, Filtered	Shows how to install a filtered product door and its associated hardware.
<i>If applicable:</i> Product Doors, Solid	Shows how to install a solid product door and its associated hardware.
Roof Panels	Shows how to install the roof panels.
Temp Sensor & Diffuser/Baffle	Provides instructions for installing the temperature sensor and a diffuser (for an air heater with side-discharge into the booth) or a baffle (for an air heater with down-discharge into the booth).

Required materials

This section lists the tools, equipment, and documentation required for installing your booth.

NOTE

Depending on the type of equipment you are installing, additional tools may be required.

Required tools

- Screwdrivers
- Wrenches and socket set
- Hammer and mallet
- Load bar that can extend to at least 9 feet (108 inches)
- Filter-insertion tool (metal pizza cutter; approximately 3-inch to 4-inch diameter)
- Drift pins (two per person; 1/8-inch to 5/8-inch taper)
- Caulk gun
- Impact driver and drill
- Unibit or step drill bits
- Chalk and/or felt-tip marker (for marking initial measurements on floor)
- Chalk-line tool
- 4-foot box level
- Laser level (*Suggested:* Quad laser or rotary laser level)
- Tape measures (35-foot and 100-foot)
- Tin snips
- Duct crimping tool
- Torque nut runner
- Reciprocating saw
- *Optional:* Torch and welder in case modifications need to be made on site

Recommended equipment

- Ladders
- Two or more sawhorses
- Two 26-foot T scissor-lift platforms

NOTE

Lifts and cranes are not required, but they may improve both the safety and speed of installation.

NOTE

The end user is responsible for providing any lifts, cranes, and material handlers. Alternatively, the end user can coordinate with the installer so the installer can rent those items before starting the work.

Installation best practices

Unpack in stages

As you begin each section of the installation procedure, unpack the crate(s) that contain the parts for that section. In general, the skids are organized so the parts that go together during assembly are packed on the same skid.

NOTE

For faster unpacking, use a reciprocating saw to cut the crates.



Figure 2. Skids awaiting unpacking

A packing list is attached to each crate. As you unpack a crate, compare all the parts with that crate's packing list to check for shortages or losses in transit. Also check parts for any damage that might have been caused in shipping.

NOTE

Slightly bent panels and angle braces can be straightened and will cause no performance or assembly problems.

If any parts are missing or damaged, contact Global Finishing Solutions at 800-848-8738 to speak to a Technical Service Representative.

Sort parts by size

To help installation proceed more efficiently, sort all parts by size as you unpack them (Figure 3).

Each part has a specific part number. The part number is either etched into the part or printed on a label affixed to the part (Figure 4).



Figure 3. Panels sorted by size in preparation for assembly

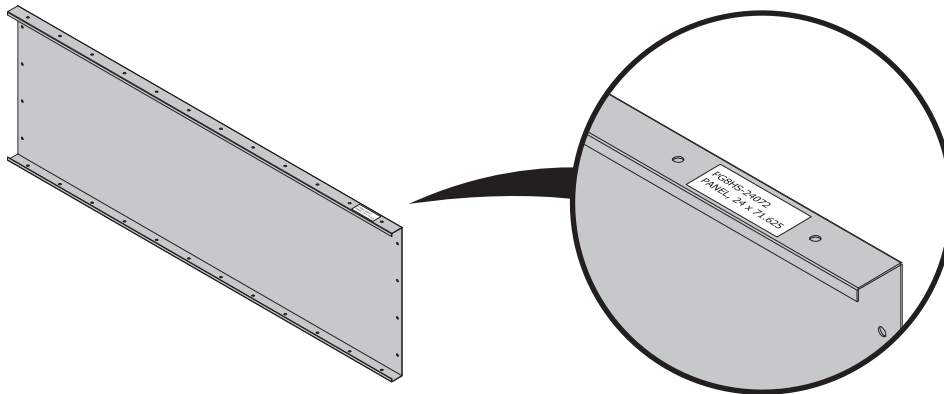

Figure 4. Example of a part number label

Follow assembly guidelines

Follow these guidelines when assembling the booth:

- Assemble the booth in sections, following the sequence provided in this document.
- As you build each section, tighten the bolts only to finger-tight.
- Before tightening the bolts within a section, confirm that the section is plumb and square.
- When directed to do so, tighten the bolts within a section to *snug-tight*. Snug-tight is defined as “the tightness that is attained with a few impacts of an impact wrench or the full effort of an ironworker using an ordinary spud wrench to bring the plies into firm contact.” (RCSC 2014)
- **For single-skin booths:** Orient panels so that each panel’s flanged side faces outward, and the non-flanged side faces the booth’s interior.
- **For all booths:** When applicable, orient bolts so that the bolt heads (and a washer) are on the booth’s interior and the threads are on the exterior.
- Use hardware as specified on the assembly drawings.
- Plumb the panels so that they are perpendicular to the floor. The sides of the booth must be parallel to each other.

Installation procedure

This procedure describes how to install a Performer ES booth.

Prepare the floor

1. Sweep the floor clear of debris.
2. Use a laser level to check the floor:
 - If the floor is out of level by **1/4 inch or less** over the full length of the booth, continue to the next step. (You do not need to take any corrective action now because you can use the supplied shim pack to correct for slope when installing frame assemblies later in the procedure.)
 - If the floor is **more than 1/4 inch** out of level over the full length of the booth, shim or grout the floor as needed to get it to within 1/4 inch of level. GFS does not supply shims for this purpose.
3. Referring to the Working Width and Working Depth from the Design Drawings, measure the booth's footprint on the floor and mark the corners.

NOTE

Ensure that the location allows for the clearances specified in "Confirming site requirements" (page 14).

NOTE

Use a piece of chalk or other temporary mark at this stage, in case you have to adjust the position of the marks in the next step.

4. Measure the diagonals to confirm that the opposite sides are parallel and that adjacent sides are perpendicular to each other.

Re-measure and adjust the corner markings as needed until the diagonals are equal length.

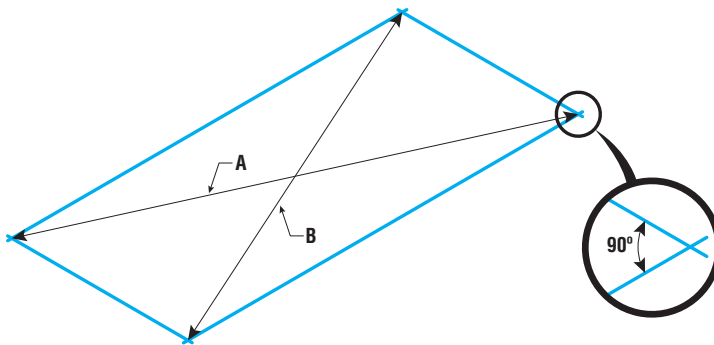

5. After confirming that the measurements are correct and the angles are 90 degrees, snap chalk lines to mark the outline of the booth's footprint.

Build the rear bay

NOTE

Use 5/16-inch x 3/4-inch bolts and nuts for all panel and tie angle connections.

Reference: Refer to the End Section page of the Design Drawings to determine which type of end bay is required at the rear of the booth:

- **Solid Back Bay:** Refer to “*If applicable: Assemble a solid-back exhaust chamber bay*” (page 24).
- **Drive-Through Bay:** Refer to “*If applicable: Assemble a drive-through exhaust bridge chamber bay*” (page 24) for a rear bay that contains a product door.

If applicable: Assemble a solid-back exhaust chamber bay

Scope: This task applies to a Performer ES that uses an exhaust chamber bay rather than an exhaust bridge (yoke) chamber bay. (If you are installing a Performer that uses an exhaust bridge chamber bay, perform “*If applicable: Assemble a drive-through exhaust bridge chamber bay*” (page 24) instead of this task.)

Prerequisites: The booth's footprint must already be marked on the floor as described in “Prepare the floor” (page 23).

Reference: Refer to the End Section page of the Design Drawings.

1. Assemble the panels and tie angles that form the rear wall and the left and right side walls of the exhaust chamber bay.
2. Assemble the panels, tie angles, and fan panel that form the roof of the exhaust chamber bay.
3. Install the filter racks.
4. Ensure that the completed exhaust chamber is plumb, square, and level.
5. Tighten all bolts in the exhaust chamber to snug-tight.
6. Install the panels and tie angles that form the left and right sides of the rear-most bay.
7. Install the hip-light panels and tie angles atop the left and right sides of the bays.
8. After tightening the end section bolts, jump to “Install the exhaust fan” (page 25).

If applicable: Assemble a drive-through exhaust bridge chamber bay

Scope: This task applies only to a Performer ES that uses an exhaust bridge chamber bay rather than a standard (non-yoke) exhaust chamber bay. (If you are installing a Performer that uses a standard exhaust chamber, perform “*If applicable: Assemble a solid-back exhaust chamber bay*” (page 24) instead of this task.)

Prerequisites: The booth's footprint must be marked on the floor as described in “Prepare the floor” (page 23)

NOTE

Use 5/16-inch x 3/4-inch bolts and nuts for all panel-to-panel, tie angle-to-tie angle, and panel-to-tie angle connections.

NOTE

Use one 5/16-inch x 1/2-inch bolt and nut every six inches for all filter rack-to-filter rack connections and for all panel-to-filter rack connections.

Reference: Refer to the End Section page of the Design Drawings.

1. Build the rear corners using the frontal header, frontal panels, and the left and right side walls of the exhaust bridge chamber bay.
2. Install the exhaust yoke filter panel assemblies.
3. Build the roof and front of the plenum.
4. Build the floor of the plenum.

NOTE

If this booth has a product door at the rear of the booth, install part of the rear door frame during this step.

NOTE

Do not install the access door at this time. You will be directed to install the access door in “Install the access door in the exhaust plenum” (page 47).

5. Ensure that the completed exhaust bridge chamber bay is plumb, square, and level.
6. Tighten all bolts in the exhaust bridge chamber bay to snug-tight.
7. Install the panels and tie angles that form the left and right sides of the rear-most bay.
8. Install the hip-light panels and tie angles atop the left and right sides of the bays.
9. After tightening the end section bolts, continue to “Install the exhaust fan” (page 25).

Install the exhaust fan

Prerequisites: The rear end wall of the booth must be assembled as directed in “Build the rear bay” (page 23).

NOTE

The direction of the fan blade rotation and the direction of the airflow are indicated on the outside of the exhaust fan housing.

Reference: Refer to the End Section page of the Design Drawings to identify the fan panel.

1. Apply caulk around the opening of the fan panel.
2. Place the first section of duct and attach it to the fan panel.
3. Place the exhaust fan on a forklift, orienting the fan so that the fan motor will be facing the appropriate side of the booth when the fan is removed from the forklift.

NOTE

Refer to the Plan View on the Concept page of the Design Drawings to see how the fan motor should be oriented relative to the booth.

4. Lift the fan to the top of the exhaust chamber and place it onto the section of duct, orienting the fan so that:
 - The arrows on the airflow label point the correct direction.
 - The holes in the fan's lower flange align with the holes in the section of duct.

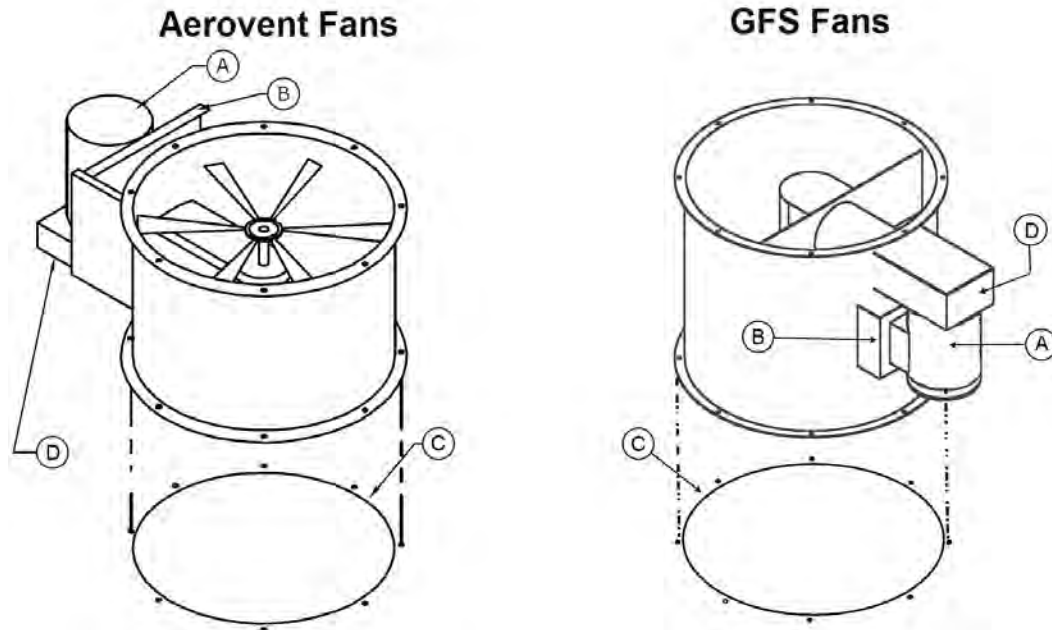

- A: Motor
- B: Motor plate
- C: Caulk location
- D: Belt guard

5. Bolt the fan to the ductwork using 5/16-inch x 1-1/2 inch bolts.

NOTE

Tighten the bolts to finger-tight until they are all installed; then tighten them to snug-tight.

6. Caulk the outside of the joint between the fan and the section of duct.

Assemble the bays

Prerequisites: The exhaust fan must be installed as described in “Install the exhaust fan” (page 25).

NOTE

Build bays in order from back to front of the booth. Thus, the first bay to be built is always the bay that contains the exhaust chamber.

NOTE

Use 5/16-inch x 3/4-inch bolts and nuts for all panel and tie angle connections.

Reference: Refer to the appropriate Bay Assembly of the Design Drawings.

Build a center bay

NOTE

Connect the center bay to the frame of the previous bay. The center bay does not contain a door.

NOTE

Use 5/16-inch x 3/4-inch bolts and nuts except where noted. Tighten all bolts onto to finger tight except where noted.

Reference: Refer to the appropriate Mid Section page of the Design Drawings as you complete this step.

1. Build the first side wall:

- a. Connect the panels and tie angles to the frame of the previous bay.

NOTE

In order to complete this step, you must remove the bolts that temporarily connected the frame assembly to the *previous* bay. After connecting the panels and tie angles for *this* bay to the frame assembly, install *all* required bolts.

- b. Assemble the frame for that side wall.

NOTE

Use 5/16-inch x 3/4-inch bolts and nuts for frame-to-panel connections.

2. Repeat the previous step to build the opposite side wall.

3. Connect the panels and tie angles to assemble the bay roof.

4. Use a forklift to lift the roof panels into position at the top of the bay; then **hold the panels in place with the forklift** while you connect it.

5. Connect the sides of the roof to the side walls of the bay.

6. **Continue holding the roof panels in place with the forklift** while you plumb and tighten the bay:

- a. Ensure that the bay is plumb, square, and level.

- b. Tighten all bolts in the bay to snug-tight *except* the bolts that are temporarily connecting the frame assembly to the bay (because you will have to remove those bolts to connect to next bay to the frame).

7. After tightening the bolts to snug-tight, remove the forklift support from under the bay roof.

8. Working from back to front, build the next bay:

- **If the next bay is a center bay** (i.e., not the front section or the end section), repeat this task.
- **If the next bay is the last bay**, follow the instructions in “*If applicable*: Build the front bay in a crossdraft booth” (page 28) or “*If applicable*: Build the front bay and front wall in a semi-downdraft booth” (page 29).

If applicable: Build the front bay in a crossdraft booth

Scope: This task applies only to crossdraft Performer ES booths.

NOTE

The front bay connects to the frame of the previous bay (toward the rear). It will also connect to a frame on its front end (installed during this step).

NOTE

Use 5/16-inch x 3/4-inch bolts and nuts except where noted. Tighten all bolts onto to finger tight except where noted.

Reference: Refer to the appropriate Front Section page of the Design Drawings as you complete this step.

IMPORTANT

The images below provide *general* building instructions and design concepts. **Always refer to the appropriate page in the Design Drawings** for guidance on your *specific* booth.

1. Build a side wall.

NOTE

Connect the panels and tie angles to the frame of the previous bay.

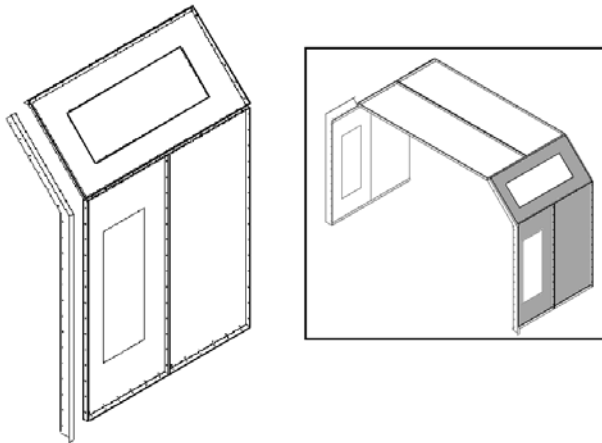

2. Use 1/2-inch x 1-inch bolts and nuts to connect a corner plate to the appropriate single-frame pieces; then connect that sub-assembly to the bay's side wall *temporarily*, using only a few bolts.
3. Repeat the previous steps to build the opposite side wall.

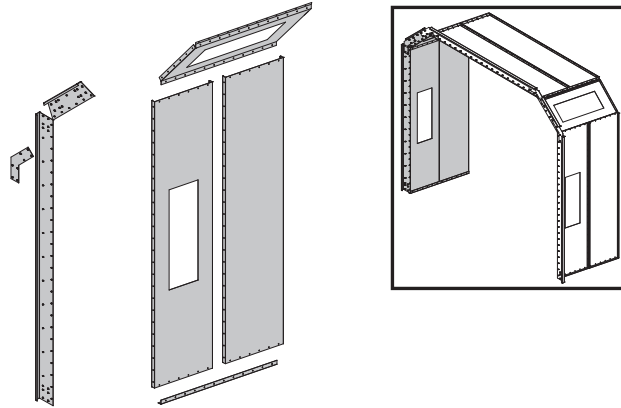

4. Build the bay roof on the floor:
 - a. Connect the panels and tie angles that form the roof.
 - b. Connect the sub-assembly to one side of the roof *temporarily*, using only a few bolts.

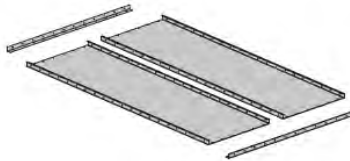

5. Use a forklift to lift the roof into position at the top of the bay; then **hold the roof in place with the forklift** while you connect it:
 - a. Connect the roof's rear panel to the frame of the previous bay.
 - b. Connect the sides of the roof to the side walls of the bay.
6. **Continue holding the roof in place with a forklift** while you plumb and tighten the bay:
 - a. Ensure that the bay is plumb, square, and level.
 - b. Tighten all bolts in the bay to snug-tight *except* the bolts that are temporarily connecting the single-frame assembly to the bay (because you will have to remove those bolts to connect to front end wall to the frame).
7. After tightening the bolts to snug-tight, remove the forklift support from under the bay roof.

If applicable: Build the front bay and front wall in a semi-downdraft booth

Scope: This task applies only to semi-downdraft Performer ES booths.

Prerequisites: All center bays (i.e., all bays between the two end bays) must be assembled.

NOTE

The front bay connects to the frame of the previous bay (toward the rear). It will also connect to the front wall (installed during this step).

NOTE

This bay connects to the frame assembly already installed on the end of the previous bay. When you connected that frame assembly to the previous bay, you were directed to use only enough bolts to hold the frame assembly in position. During this step, you must remove those temporary bolts in order to connect this bay to that frame assembly.

NOTE

If this booth is pressurized by an optional air heater or intake fan, refer to the Design Drawings to install those components during this task.

NOTE

Use 5/16-inch x 3/4-inch bolts and nuts except where noted. Tighten all bolts onto to finger tight except where noted.

Reference: Refer to the appropriate Front Section page of the Design Drawings as you complete this step.

1. Build a side wall.

NOTE

Connect the panels to the frame of the previous bay.

2. Build the **single-frame** sub-assembly for that side wall.
3. Connect the single-frame sub-assembly to the bay's side wall *temporarily*, using only a few bolts.

NOTE

Use 5/16-inch x 3/4-inch bolts and nuts for all frame-to-panel connections.

4. Repeat the previous steps to build the opposite side wall.
5. Install the side panels that form the intake plenum.
6. Install the plenum end panel at the rear of the intake plenum.
7. Use a forklift to lift the roof into position at the top of the plenum, then **hold the roof in place with the forklift** while you connect it:
 - a. Connect the roof's rear panel to the plenum end panel.
 - b. Connect the sides of the roof to the side panels of the intake plenum.
8. Continue holding the roof in place with a forklift while you plumb and tighten the intake plenum.
9. Install the plenum frontal header panel.
10. Ensure that the bay is plumb, square, and level.
11. Tighten all bolts in the bay to snug-tight (except the bolts connecting the single-frame assembly to the bay, since you will have to remove them to install the end wall).

***If applicable:* Install the intake filter supports**

Scope: This task applies only to a Performer booth that has semi-downdraft airflow. If this is a crossdraft booth, skip this task and continue to "Install the door frame for the front product door" (page 31).

Reference: Refer to the Filter Ceiling page of the Design Drawings.

1. Assemble the filter ceiling using 8 mm hardware.

NOTE

The filter frame assembly and filters that form the filter ceiling will be installed in “*If applicable: Install the intake filters in a semi-downdraft booth*” (page 48).

2. Bolt the filter support profiles to the hip light panels.
3. Bolt the filter support beams to the cabin header panels.
4. Install the filter frame hinge.
5. Caulk the filter ceiling so air cannot leak into the booth without passing through the intake filters.

Install the door frame for the front product door

NOTE

On a non-pressurized crossdraft booth, the front product door is always a filtered door.

Reference: Refer to the Product Door page of the Design Drawings.

1. Install the left and right door jamb assemblies.

NOTE

For greater efficiency, install the door jambs when you build the front wall where this door frame will be installed. If the front wall is already assembled, you will have to remove some bolts in order to install the door jambs.

2. Connect the door header assembly to the left and right door jamb assemblies.
3. Confirm that the door frame is plumb, square, and level.

NOTE

An uneven floor can cause product doors to sag or bind. If necessary, place shims under door jambs to even the doors out. GFS does not provide shims for product doors.

4. Tighten all bolts in the door frame to snug-tight.

NOTE

Do not anchor the door jambs at this time. You will be directed to anchor the door jambs later in the procedure.

Anchor the bays

Prerequisites: All bays must be completely assembled as described in “Assemble the bays” (page 26).

Reference: Refer to the General Structural Notes page of the Design Drawings.

1. Double-check that each bay and each frame assembly is plumb, square, and level.
2. Double-check that all bolts have been installed and are tightened to snug-tight.
3. Working from back to front, anchor each bay and each frame assembly.

NOTE

For instructions on anchoring, refer to the “Panel to Slab Connection” view and related notes on the General Structural Notes page of the Design Drawings.

Install a product door

Prerequisites: The appropriate door frame must be installed at the front of the booth. If this booth is a drive-through booth, the appropriate door frame must be installed at the back of the booth.

Reference: Refer to the appropriate Product Door page of the Design Drawings.

1. Install the hinges and hang the product door as directed on the appropriate Product Door page.

NOTE

Refer to the Door Hinge Detail view on the appropriate door Product Door page.

2. Align and square the doors.

NOTE

Check the gaps between hinged connections and ensure that they meet the specifications on the appropriate Product Door page.

CAUTION

Proper door alignment is critical to the operation of the booth. Ensure that there is equal space around the doors. Move the bottom of the door jamb to the left or right or in and out until the doors are sealed and plumb.

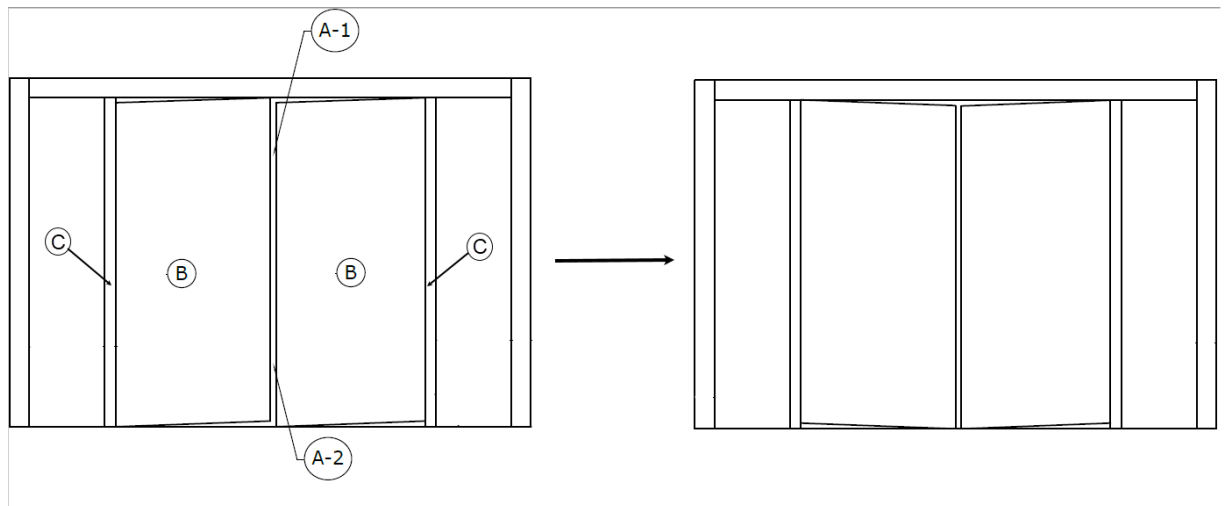

A: Gap between doors: The gap between the doors at the top (A-1) must be equal to the gap between the doors at the bottom (A-2)

B: Door slab

C: Door jamb

3. Once the doors have been squared and gaps are established, tighten the bolts to snug-tight and install Tek screws to lock them into place.
4. Anchor the door jamb to the floor.

NOTE

For instructions on anchoring, refer to the “Jamb to Slab Connection” view and related notes on the General Structural Notes page of the Design Drawings.

5. *If applicable for this door:* Anchor the end wall to the floor.

NOTE

This step applies only when you are installing a non-roll-up door at the front of the booth. Do not perform this step if you are installing a non-roll-up door at the rear of the booth.

NOTE

For instructions on anchoring, refer to the "Panel to Slab Connection" view and related notes on the General Structural Notes page of the Design Drawings.

6. Install the door handles.

NOTE

Position the handles as shown on the Product Door page of the Design Drawings.

7. Install the door seals:

- a. Affix P-seal gasket along the left and right door jambs; cut to length.
- b. Affix P-seal gasket along the door stop; cut to length.
- c. Affix the large D-seal gasket along the header; cut to length.

NOTE

Refer to the appropriate Product Door page of the Design Drawings document for seal locations.

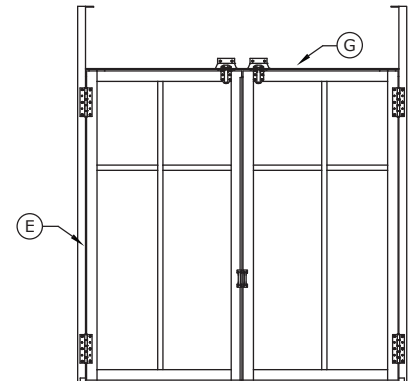
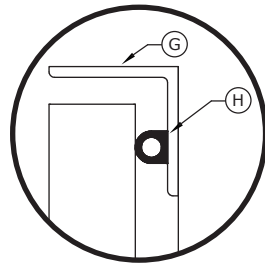
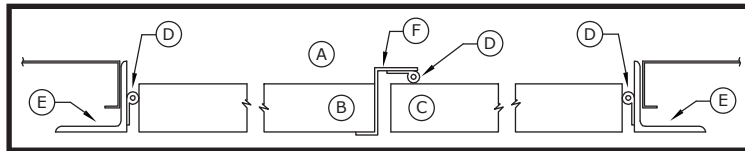

- A: Booth interior*
- B: Left door*
- C: Right door*
- D: P-seal gasket*
- E: Door jamb*
- F: Door stop*
- G: Door header*
- H: Large D-seal gasket*

8. Remove the pre-installed door sweep; level it with the floor and cut accordingly; then reattach it to the door.

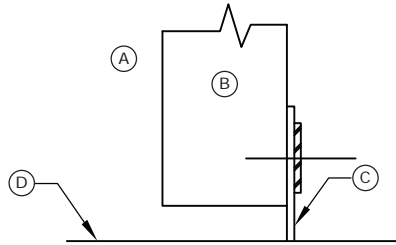

- A: Booth interior
- B: Product door
- C: Door sweep (installed at GFS)
- D: Finished floor

9. Place plugs (GFS part number 1014081) in all large open holes.

Install the personnel door

Prerequisites:

- The booth assembly must be complete, and all sections of the booth must be snug-tightened and anchored to the floor.
- The door jambs and headers for the personnel doors should be already installed in the side walls of the appropriate bay(s).

IMPORTANT

The images below provide *general* building instructions and design concepts. **Always refer to the appropriate page in the Design Drawings** for guidance on your *specific* booth.

Mount the door

1. Confirm that the door frame is plumb, square, and level.
2. Use 5/16-inch x 3/4-inch bolts to mount the hinges to the personnel door.

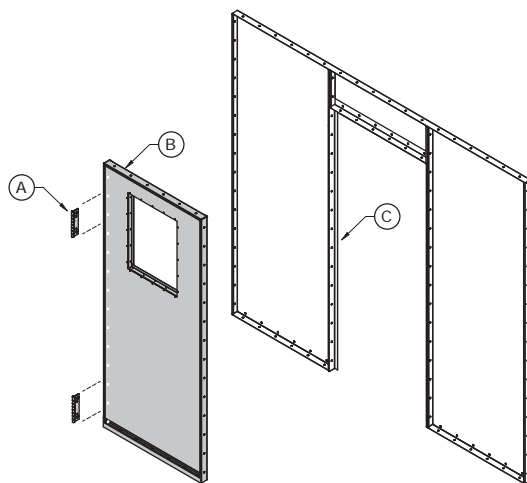

- A: Hinge
- B: Personnel door (with or without window)
- C: Door jamb

3. Use 5/16-inch x 3/4-inch bolts and nuts to mount the hinges to the door jamb.

Attach the handles

Reference: Refer to the Installation Instructions page for the personnel door (provided in the personnel door kit inside the "Miscellaneous" box).

Use Tek screws to fasten a door handle to each side of the door.

NOTE

Follow the positioning guidelines in the accompanying diagram.

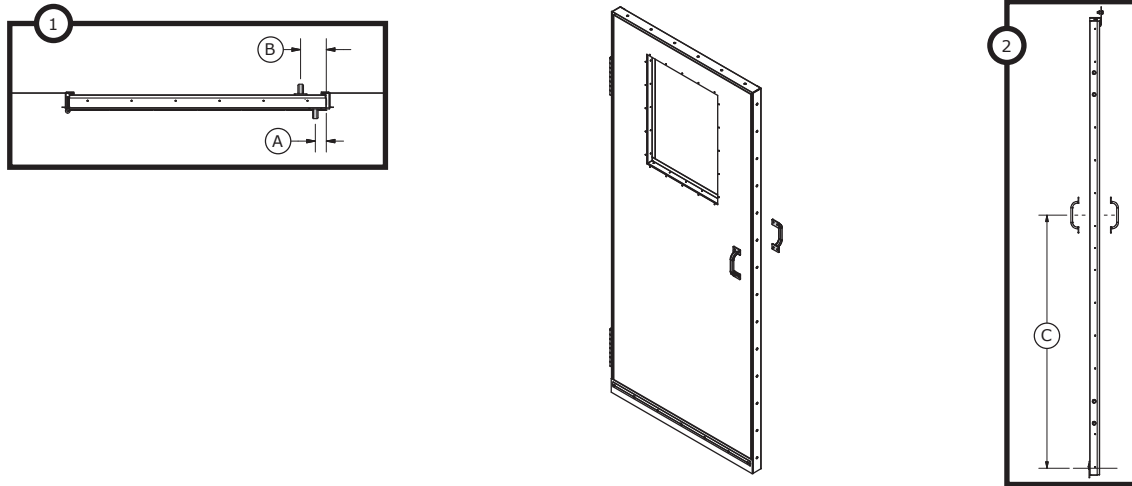

A: Horizontal placement, outer handle: 1-1/2 inches from door edge

B: Horizontal placement, inner handle: 3-1/2 inches from door edge

C: Vertical placement (both handles): 4 feet 0 inches from bottom of door to center of handle

Install door seals

NOTE

Refer to the following diagram while completing this task.

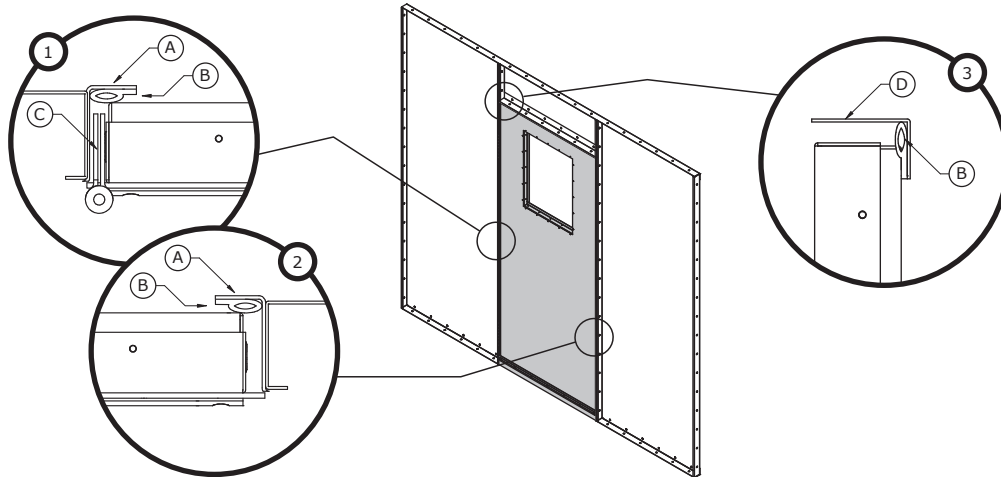

A: Door jamb
B: P-seal
C: Hinge
D: Door header

1. Affix P-seal gasket along the left and right door jambs; cut to length.
2. Affix P-seal gasket along the header; cut to length.

Assemble the exhaust stack

Prerequisites: The exhaust fan must already be installed.

IMPORTANT

If the roof opening is already cut, install all exhaust ductwork (including the ARV) during this step. If the roof opening is *not* cut, install the exhaust ductwork to just below the roof. (In that case, you will have to finish installing the rest of the ductwork later, after the roofer has cut the roof opening.)

NOTE

Per NFPA 33, the air inlet hood on top of the intake stack and the automatic roof ventilator (ARV) on top of the exhaust stack must be at least 10 feet away from each other.

NOTE

To connect duct sections together:

- Slip the bottom of one duct section into the top of the previous duct section.
- Ensure that the duct section is level north-south and east-west.
- Tek-screw the duct section to the previous duct section from the inside out.

Reference: Refer to the diagram below.

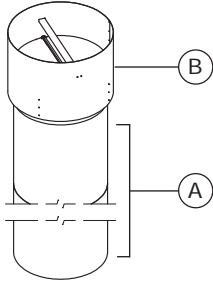

A: One or more sections of plain duct
B: Automatic Roof Ventilator (ARV)

1. Confirm that a fan ring is bolted to the top of the exhaust fan.

NOTE

If the fan ring is not present, install it now as directed in .

2. Connect a section of plain duct to the fan ring.
 - a. Place a plain duct section over the duct lip of the fan ring.
 - b. Ensure that the duct section is level north-south and east-west.
 - c. Tek-screw the duct section to the duct lip from the inside out.
3. *If applicable:* Continue connecting all the necessary plain duct sections as required for the exhaust stack.

NOTE

Follow the procedure for connecting duct sections together in the notes at the beginning of this task.

4. Install the ARV:
 - a. Slip the bottom of the ARV over the top-most duct section.
 - b. Ensure that the ARV is level north-south and east-west.
 - c. Tek-screw the ARV to the duct section from the inside out.
5. Working down from the ARV to the exhaust fan, caulk the outside of all connections in the exhaust stack.

NOTE

Caulk all duct-to-duct connections and all assembly seams.

If applicable: Install the guy-wire kit

NOTE

Install the guy-wire kit per the instructions below. It is the responsibility of the customer or their agent (for example, a roofer or building contractor) to supply and install the cable tie-off points on the building roof (plate with ring). The diagram below is provided for reference only.

NOTE

Use #10 Tek screws to attach duct strap to exhaust duct; caulk to seal.

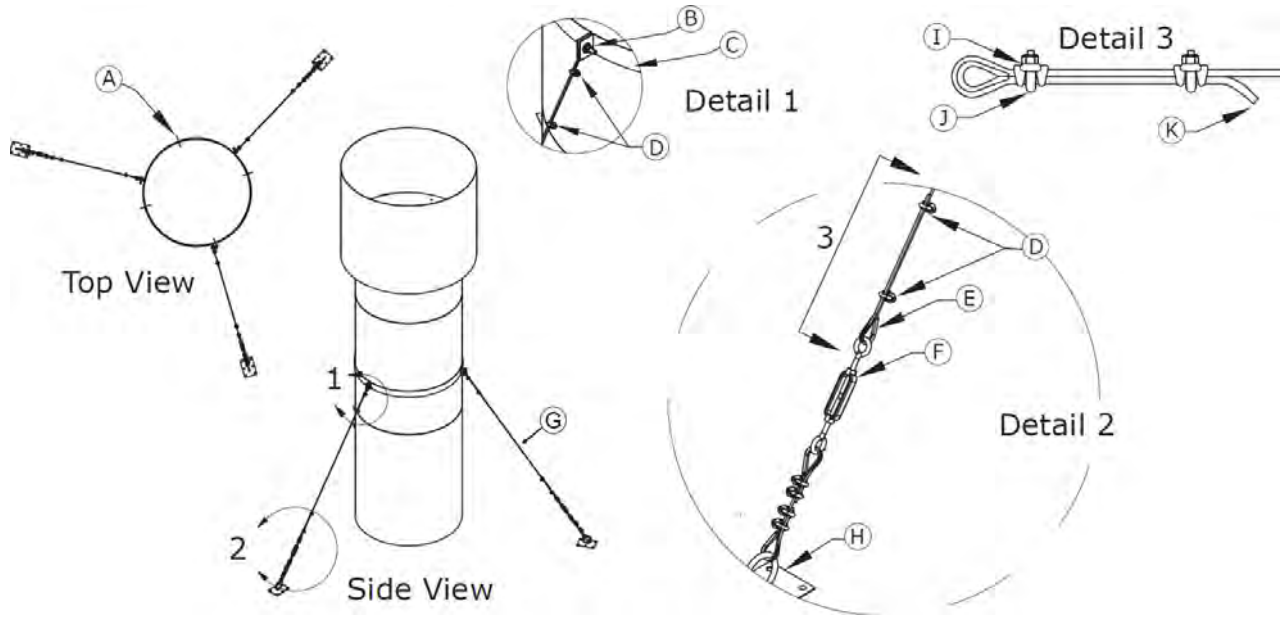

- A: #10 Tek screw
- B: For each connection, use one cable thimble; one 5/16-inch x 1-1/2-inch bolt; two 5/16-inch flat washers; one 5/16-inch lock washer; and one 5/16-inch nut.
- C: Duct strap
- D: Cable clamps (2)
- E: Thimble
- F: Turnbuckle
- G: Cable; thimbles (2); cable clamps (4)
- H: Plate with ring
- I: Grip base
- J: U-bolt (must have U-bolt over dead end of cable)
- K: Dead end

Install the lights

Prerequisites: The booth must be assembled.

NOTE

This task covers only the mechanical installation of the lighting fixtures; wiring should be performed by a qualified electrician as specified in “Perform electrical hookup” (page 47).

Install cage nuts in the light fixtures

NOTE

It is usually more efficient to install the cage nuts in all the light fixtures at one time (before you begin installing the lights).

1. Open the boxes containing the light fixture(s) and remove the hardware kit and the manufacturer’s instructions.
2. For each square hole on the light fixture box: Insert a cage nut into the hole and snap into position.

NOTE

Some force is required to snap in the nut.

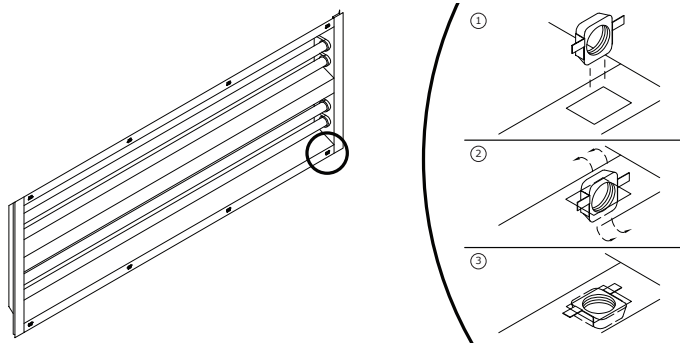

3. Confirm that each cage nut can slide within its hole.

NOTE

The cage nut must be able to slide to ensure that it can align with the cover bolt.

4. Repeat this procedure as needed to install cage nuts in all light fixture boxes.

Install light fixtures in panels

Prerequisites: Cage nuts must be installed in each light fixture as directed in “Install cage nuts in the light fixtures” (page 38).

IMPORTANT

Make sure to position the light’s power cord (“whip”) on the back side of the light fixture (i.e., on the side that faces the exterior of the equipment). Wire to NFPA 70 and do not run wiring over the face of beams.

NOTE

Refer to the following diagram as you complete this task.

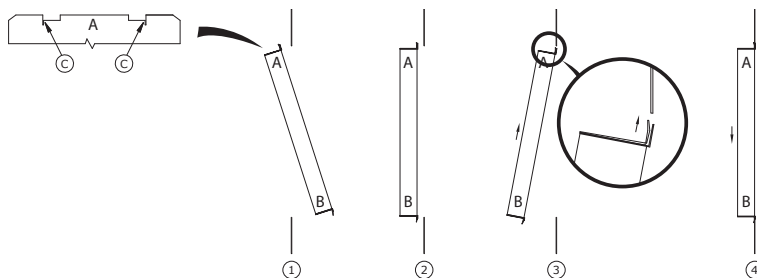

- A:** Flange with notches
- B:** Flange without notches
- C:** Slot in notch

1. Obtain a light box with cage nuts already installed.
2. Stand facing the light panel from the interior and hold the light fixture so that its flanged edge is toward you, with the notched flange “A” on the side.
3. Insert the light fixture into the opening of the panel with flange “A” up.
4. Slide the fixture up until flange “B” engages the lower edge of the opening in the panel; then lower the fixture.
5. Bend the edges of each notch so that the light panel fits into the slot at the corner of the notch.

Installation procedure

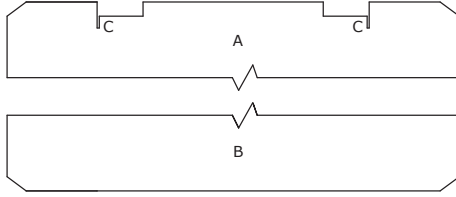

- A:** Flange with notches
- B:** Flange without notches
- C:** Slot in notch

Install covers over light fixtures

Prerequisites: The light fixture must be installed in the light panel as directed in “Install light fixtures in panels” (page 39), with the whip positioned on the back side of the light fixture.

Place a light fixture cover over the light fixture and attach it using 6-mm x 20-mm cap-head screws.

NOTE

To prevent damage to the cover, finger-tighten each of the cap-head screws to a torque rating between 2 and 5 inch-pounds.

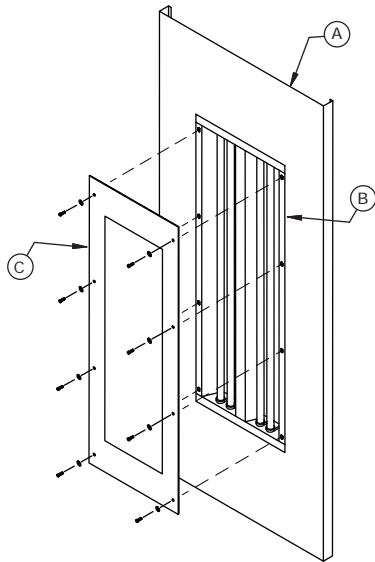

A: Light panel
B: Light fixture installed in light panel
C: Light cover

If applicable: Install the manometer

Scope: This task applies only to the standard manometer (GFS part number 1011003) paired with GFS single-stage exhaust filter media. Only non-pressurized Performer ES booths or booths pressurized with an intake fan will include a manometer.

1. Position the manometer on the outside of the booth.

NOTE

Choose a convenient location, approximately 5 feet from the floor and within 3 feet of the filter bank.

2. Drill two holes (1/8-inch or 9/64-inch in diameter) on a vertical line 3-15/16 inches apart for the provided fittings.
3. Loosely mount the manometer with the provided self-tapping screws.
4. Adjust the gauge until the bubble is centered in the level vial, then secure the manometer tightly.
5. Install tubing adapters on each side of the filter.
6. Run tubing:

- a. Run the high-pressure line (left fitting) to the booth.
- b. Run the low-pressure line (right fitting) to the exhaust chamber.

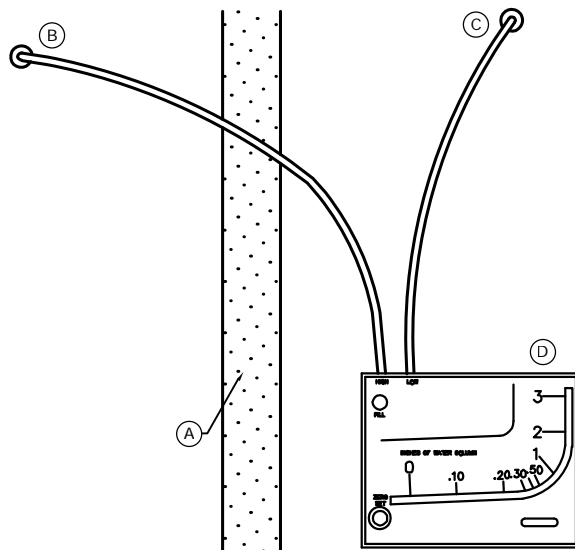

- A:** Filter media
B: High-pressure line to booth side of filters
C: Low-pressure line to chamber side of filters
D: Manometer

7. Turn the white adjustment knob counterclockwise until it stops, then turn clockwise three full turns. This puts zero approximately in the middle of the travel adjustment in either direction.

8. Remove the fill plug and carefully pour the red indicating fluid until it reaches zero on the scale.

NOTE

Minor adjustments can be made by turning the white adjustment knob.

9. Replace the fill plug.

NOTE

If the gauge is overfilled, remove the excess by inserting a pipe cleaner through the fill port to blot up excess fluid.

10. Place the supplied red pointer flag at the appropriate location referenced below (indicating dirty filters):

- **GFS Wave®:** 1/2 inch w.c.
- **GFS Poly™:** 1/2 inch w.c.

NOTE

For other filters, the differential setting should be adjusted to the manufacturer's recommendations.

Install the control panel

NOTE

The control panel houses Main Disconnect, Lighting, and Motor Branch Circuit Protection per NEC requirements. It also houses all operator controls.

NOTE

This task covers only the mechanical installation of the control box; wiring should be performed by a qualified electrician as specified in “Perform electrical hookup” (page 47).

NOTE

If you mount the control panel to the side of the booth (rather than mounting it to an adjacent wall), GFS recommends that you use strut channel with strut hardware. You can cut the strut to span the distance between booth back brake flanges in the dimensions that will allow the control panel to be mounted to the strut. When mounting large enclosures, GFS recommends that the strut extend up from the floor for extra support. **Strut channel is not provided by GFS.**

Mount the control panel either on the exterior booth wall or an adjacent wall.

NOTE

Position the control panel so that its top is between 70 and 74 inches from the floor. The control panel must be at least 36 inches (914 mm) from any booth opening.

NOTE

Do *not* mount the control panel inside the booth enclosure.

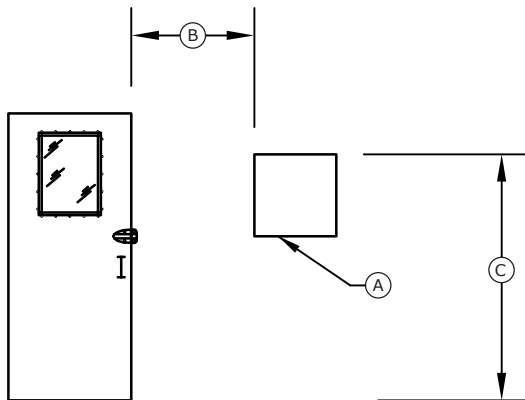

A: Control panel

B: Minimum of 36-inches between the control panel and any booth doors or openings

C: 70 to 74-inches from the floor to the top of the control panel

Install miscellaneous electrical devices

NOTE

Ensure that the placement of all electrical devices meets the NEC requirements for clearance from combustible areas.

NOTE

This section provides instructions for installing miscellaneous electrical devices. As you install each device, retain any unused hardware. Place unused hardware in a bag and tape it to the device so that it will be available for the electrician.

Install the air-proving switch for the exhaust stack

Scope: This task applies only if the site purchased an optional air-proving switch for the exhaust stack.

NOTE

Refer to the following diagram to complete this task.

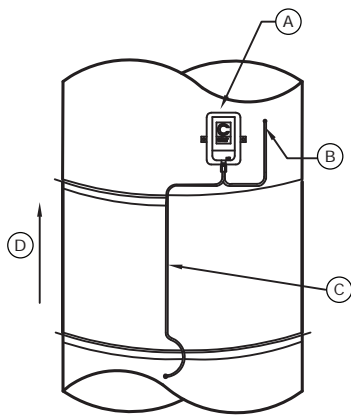

A: Pressure switch

B: High-pressure line to exhaust stack

C: Low-pressure line to intake of fan

D: Airflow

Install the air solenoid valve

Prerequisites: The booth's air supply line must already be installed.

NOTE

This task covers the installation of the directional valve in the compressed air line piping, and is usually performed by a plumber or mechanical contractor. An electrician will perform the wiring from the valve to the control panel, as described in "Perform electrical hookup" (page 47).

Install the air solenoid valve as close as possible to where the compressed air enters the booth, but no closer than 3 feet to any door or opening.

NOTE

Refer to the following diagram to complete this task:

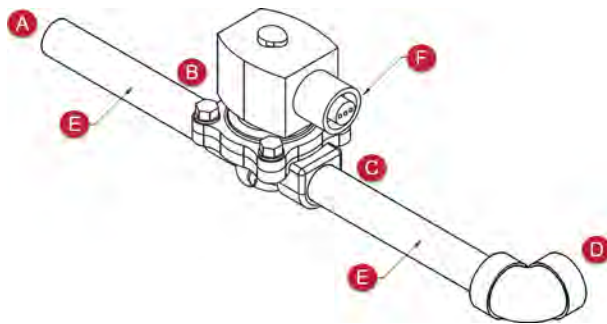

- A: From building air supply*
- B: Inlet*
- C: Outlet*
- D: Through booth wall*
- E: NPT pipe nipple (size will vary)*
- F: Conduit with wiring to control panel*

Install the Economy Mode switch

Prerequisites: The booth's air supply line must already be installed.

NOTE

The Economy Mode switch is standard on all auto refinish booths that have an air heater.

NOTE

This task covers the installation of the switch in the compressed air line piping and is usually performed by a plumber or mechanical contractor.

NOTE

Compressed air must be clean, filtered, and dry.

Connect the Economy Mode switch into the air line just before the air solenoid valve (i.e., between the air supply coming from the building and the air solenoid valve).

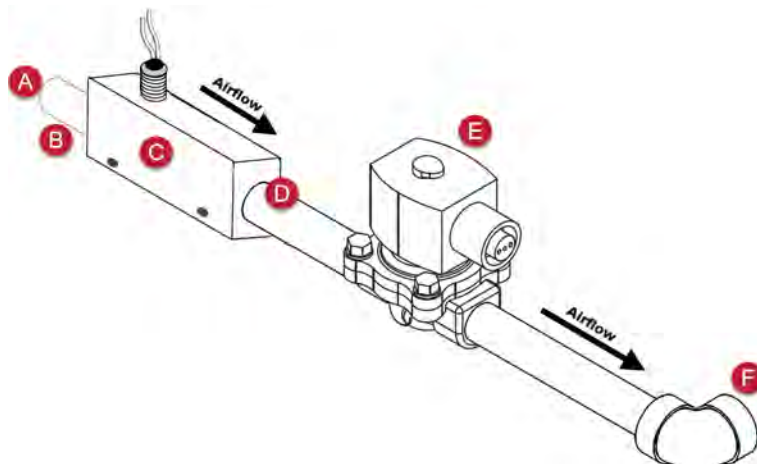

- A: From building air supply
- B: 1/2-inch NPT
- C: Economy Switch
- D: Outlet
- E: Air solenoid valve
- F: Through booth wall

NOTE

Install the switch horizontally, with electrical to the top.

Figure 5. Economy Switch Installation (Thomas Products Model Number 1500)

Caulk the booth

Prerequisites: The booth must be assembled and anchored to the floor, with the lights already installed.

NOTE

Do *not* caulk around the light fixtures.

Caulk all booth panel seams, including panel to floor (after the booth is tightened and secured to the floor).

Perform electrical hookup

WARNING

Electrical installation should be completed by a qualified electrician. Installation must meet all applicable national, state, and local electrical codes.

Wire miscellaneous electrical devices

Reference: Refer to the Electrical Drawings document while completing this task.

1. Complete the wiring for the following items:
 - Exhaust fan
 - Control panel
 - Lights
 - Air-proving switches (exhaust stack and intake duct, as needed)
 - Air solenoid valve
2. Complete the wiring for any of the following items that are included with this booth:
 - *If applicable:* Air heater
 - *If applicable:* Proximity switches on product doors and personnel doors
 - *If applicable:* Air-sensing tube (AST)

NOTE

Plumbed by the electrician.

- *If applicable:* Consta-Flow System
- *If applicable:* Economy Mode switch and gun hanger

Install the access door in the exhaust plenum

NOTE

The access door fits over the cutout in the floor of the exhaust plenum.

Reference: Refer to the Access Door Section detail on the Exhaust Bridge Chamber page of the Design Drawings document.

IMPORTANT

The images below provide *general* building instructions and design concepts. **Always refer to the appropriate page in the Design Drawings** for guidance on your *specific* booth.

1. Obtain the access door for the exhaust chamber and make sure the vinyl tape (GFS part number 1014886) has been applied around all four sides of the access door, in the area between the bolt holes, and in the raised inset.

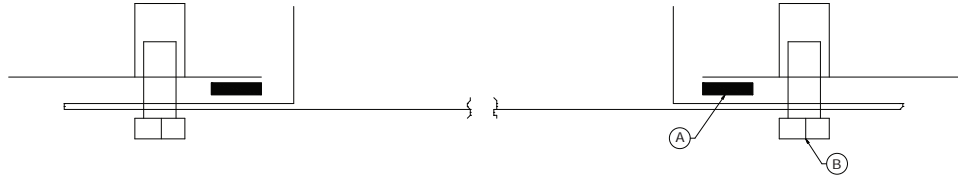

- A: Vinyl tape
- B: 5/16-inch x 3/4-inch bolts

2. Working from the underside of the plenum floor, insert the access door up into the opening on the floor of the exhaust chamber's plenum.

Then use 5/16-inch x 3/4-inch bolts to connect the access door to the plenum panel.

Install filters

Prerequisites: Complete all other installation tasks before installing the filters. Waiting until the end of the procedure to install the filters helps ensure that the filters remain clean.

If applicable: Install the intake filters in a crossdraft booth

NOTE

On a crossdraft booth, the intake filters are inserted into filter racks located in the filter door at the front of the booth.

Insert intake filters into the filter racks so that the tacky side of the filter is toward the air-leaving side of the booth.

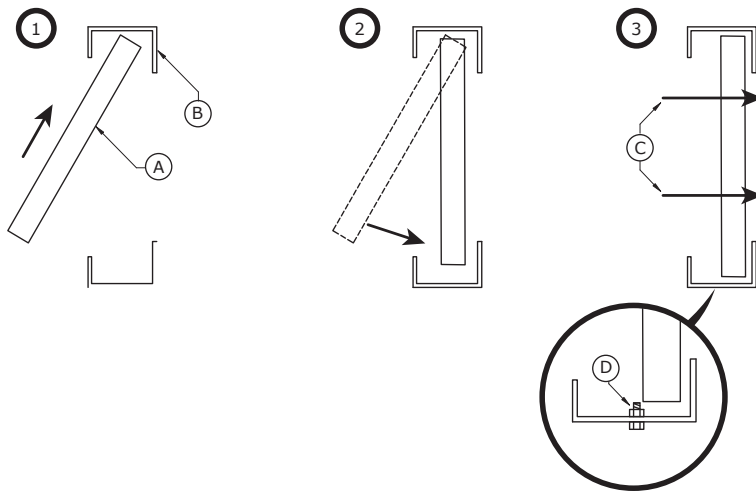

- A: Tacky side of intake filter
- B: Filter rack
- C: Airflow direction
- D: Keep the filter under the bolt or bolt head

If applicable: Install the intake filters in a semi-downdraft booth

NOTE

Perform this task for each filter rack.

1. Obtain the filter ceiling racks (assembled in “*If applicable: Install the intake filter supports*” (page 30) and place it on two sawhorses, with the flat side of the filter rack facing down.
2. Place the filter media on top of the filter rack, with the writing on the filter media facing down.
3. Use a filter-insertion tool (metal pizza cutter) to push the filter media into the slot all around the perimeter.

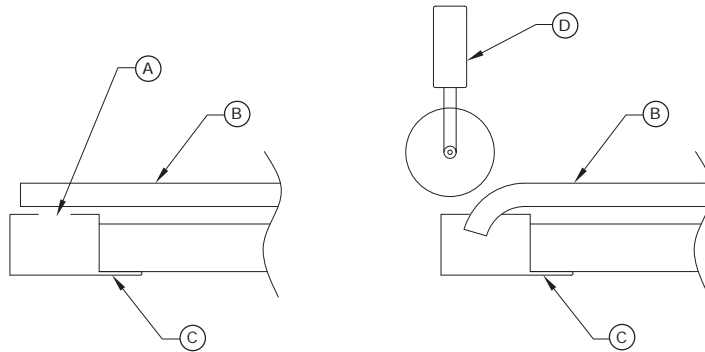

- A:** Slot in filter rack
B: Filter media
C: Filter rack
D: Filter-insertion tool (metal pizza cutter)

4. Install the filter rack in the ceiling of the booth.

Install the exhaust filters

Prerequisites: Complete all other installation tasks before installing the filters. Waiting until the end of the procedure to install the filters helps ensure that the filters remain clean.

1. Remove the filter grids from the carton.
2. Place rubber tips onto the four straight corners of the filter grids.

NOTE

The rubber tips hold the grid in place.

NOTE

Do not push the rubber tip all the way onto the grid end.

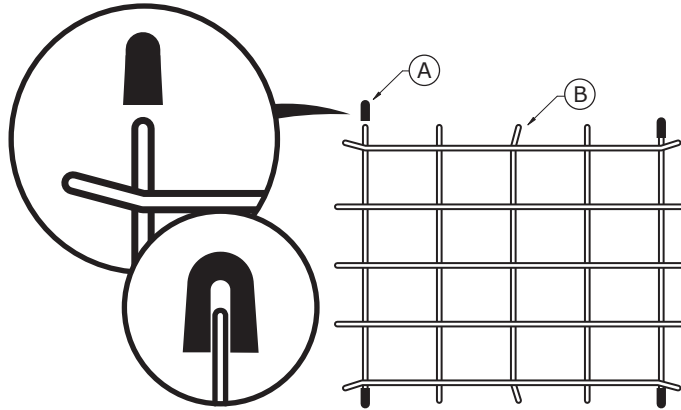

A: Rubber tip
B: Filter grid

3. Place the grids into the openings in the exhaust chamber filter racks; then install the filters onto the grids.

NOTE

Pay attention to the orientation of the filter, as shown in the accompanying diagram.

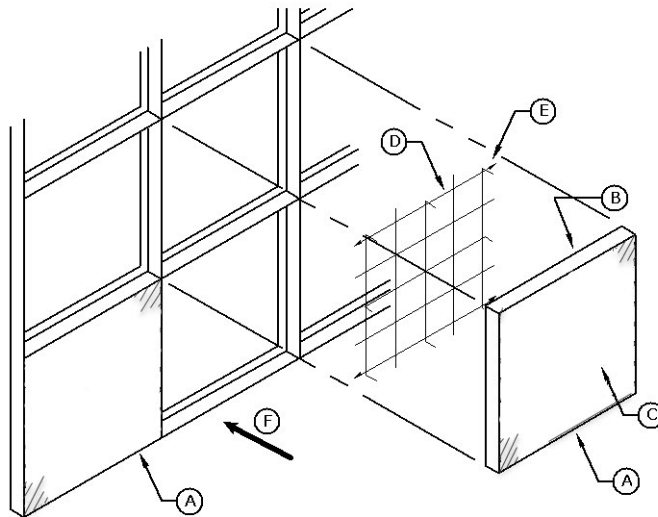

A: Exhaust filter
B: Air-leaving side (dense side of filter)
C: Air-entering side
D: Filter grid
E: Rubber tip on grid corner
F: Airflow

Perform commissioning and startup

Prerequisites:

- The booth must be fully assembled and caulked.
- Intake filters and exhaust filters must already be installed.
- The air heater must have been vacuumed or swept out, and the air heater filters must already be installed.
- An electrician must have completed the electrical hookup.

NOTE

A trained GFS Distributor usually performs booth startup. The person who performs booth startup is responsible for completing the Final Commissioning Document and returning a signed copy to GFS.

Reference: Refer to the Final Commissioning Document. (For information on locating the Final Commissioning Document, see “Gathering required documentation” (page 13).)