



GLOBAL
FINISHING
SOLUTIONS



Ultra[®] Semi-Downdraft Booth with BT Air Heater

Installation Manual

Document Number: 239-055 rev 4

Publication date 01/20/2022

Read and keep this manual for future reference. All personnel operating the equipment described in this manual should review and understand all instructions before use.

Table of Contents

Introduction	4
About Global Finishing Solutions LLC	4
Contacting Global Finishing Solutions	4
Target audience	4
Conventions used in this manual	5
Safety notices	5
Information notices	5
General safety	6
Booth safety	9
Booth description	12
Preparing for installation	13
Accepting delivery of your booth	13
Gathering required documentation	14
Confirming site requirements	15
Confirming booth layout	15
About the Design Drawings document	17
Page elements	17
Page types	19
Required materials	21
Required tools	21
Recommended equipment	22
Installation best practices	23
Unpack in stages	23
Sort parts by size	24
Remove protective coating	24
Follow assembly guidelines	25
Installation procedure	26
Prepare the floor	26
Mark the booth footprint	26
Mark the air heater footprint	27
Install the BT air heater	27
<i>If necessary:</i> Install the intake stack now	28
Install the floor channel	28
Assemble the walls for the front section of the booth	28
Build the front section of the side wall that connects to the air heater	29
Build the front wall of the booth	30
Build the front section of the opposite side wall	33
Install the plenum end panel	33
Finish the side walls of the booth	34
Build the back wall of the booth	35
<i>If applicable:</i> Build a solid end wall	35

<i>If applicable:</i> Build a drive-through end wall	35
Assemble the exhaust yoke	36
Install the exhaust fan	36
<i>For roof height over 15 feet:</i> Install the exhaust stack now	38
Assemble the top of the booth	38
Install the high roof panels	38
Install the hip light panels	39
Install the roof support assembly	39
Install the filter ceiling	39
Install the low roof panels	39
<i>If applicable:</i> Install the AdvanceCure system	40
<i>If applicable:</i> Install the AdvanceCure cover kit	40
Install the product door	40
Install the door frame	40
Install the locking rods and door hardware	41
Install the door slabs	41
Install the personnel door	41
Install the corner covers	42
Install the diffuser assembly	42
Install the intake and exhaust stacks	42
Assemble the intake stack	42
Assemble the exhaust stack	43
<i>If applicable:</i> Install the guy-wire kit	45
Install the lights	45
<i>If applicable:</i> Install optional booth accessories	46
Install the operator interface terminal	46
Install miscellaneous electrical devices	47
Install the air-sensing tube	47
Install the temperature sensor	48
<i>If applicable:</i> Install the damper actuators	48
Install the air solenoid valve	49
Install the Economy Mode switch	50
Install the air-proving switch for the exhaust stack	50
<i>If applicable:</i> Install the puff switch	51
Secure the wall panels to the floor profile	51
Caulk the booth	51
Prepare the air heater for startup	51
Install booth filters	51
Install the filter racks and intake filters	51
Install the exhaust filters	52
Perform electrical hookup	53
Perform commissioning and startup	54

Introduction

About Global Finishing Solutions LLC

Leading the Industry in Paint Booth and Finishing System Technology

With decades of experience, Global Finishing Solutions is the leading manufacturer of paint booths and finishing systems for many industries, including automotive refinish, aerospace and defense, industrial manufacturing, woodworking, and large equipment. By combining high-quality components, strong relationships with paint manufacturers, and our experienced distribution network, GFS provides the best equipment and support to set your business up for success.

Contacting Global Finishing Solutions

General information

- Toll-free: 800-848-8738
- Fax: 715-597-2193
- Email: info@globalfinishing.com
- Online: www.globalfinishing.com

Technical support

- Toll-free: 800-848-8738
- Fax: 715-597-8818
- Email: techservices@globalfinishing.com

Parts and filters

- Toll-free: 800-848-8738
- Fax: 888-338-4584
- Email: parts@globalfinishing.com

Target audience

This document is intended for use by trained, experienced paint booth installers and maintenance technicians. If you have questions about the installation procedure described in this manual, contact GFS as described above.

Conventions used in this manual

This section describes how information is presented, organized, and referenced within this manual.

Safety notices

This manual uses the following standards to identify conditions related to safety hazards and equipment damage.

Table 1. Safety notices

Symbol	Description
DANGER	Indicates an imminent hazard that will result in death.
WARNING	Indicates a hazard that can result in serious personal injury or death.
CAUTION	Indicates a hazard that can result in personal injury.
NOTICE	Indicates a situation that can result in equipment or property damage, but poses no risk of personal injury.

Information notices

In addition to the safety notices described above, this manual uses a boldface keyword to identify certain other types of information.

Table 2. Information notices

Keyword	Description
NOTE	Denotes general information that provides additional context or guidance.
Important	Denotes information to which you should pay special attention.
Reference	Directs you to related content in a separate document.
Prerequisites	Specifies other tasks that must be completed or conditions that must exist before you perform the current task.
Scope	Describes limitations to the current task or conditions under which the task applies or does not apply to the procedure.

General safety

Follow all safety guidelines when assembling, operating, or servicing this product.

WARNING

There are inherent hazards associated with the operation and service of this equipment. For your personal safety, observe all safety information. Failure to observe these safety practices can result in personal injury or death.

WARNING

Operation and maintenance of this product must be performed properly by qualified personnel who observe the warnings in all documentation and notes provided with and on the product.

WARNING

Follow all general standards for installation and safety for work on installations. Follow all good practices for the proper use of lifting tackle and equipment. The use of protective equipment such as safety goggles and protective footwear must be considered.

WARNING

All persons who will operate, service, inspect, or otherwise handle this product must read and understand the safe operating practices, safety precautions, and warning messages in this documentation.

WARNING

The roofs of GFS equipment are not designed or intended to be walked upon or to support weight of any kind. As designed and manufactured, equipment roofs do not meet the minimum requirements of a safe walking and/or working surface under OSHA 1910.22. Under no circumstances should the roof be used by maintenance personnel or others for walking, standing, or storage of any kind. When necessary, roof access should be secured through the use of a properly supported platform that satisfies the minimum load requirements specified by ASCE 7 (Minimum Design Loads and Associated Criteria for Buildings and Other Structures) and ASCE 37 (Design Loads on Structures during Construction). Additionally, personnel should always utilize appropriate fall safety protocols when using an elevated platform. Use of the roof in a contrary manner may result in injury and/or death.

WARNING

Comply with OSHA guidelines and with all applicable local electrical, safety, and fire codes and standards.

WARNING

All field wiring provided must comply with local codes or, in the absence of local codes, the National Electrical Code (NFPA 70). Article 516 covers applicable of flammable and combustible materials.

WARNING

Electrical installation should be completed by a qualified electrician. Installation must meet all applicable national, state, and local electrical codes.

WARNING

Ensure that all electrical components are grounded to a central ground.

WARNING

Disconnect and lock out the main electrical service before installing, adjusting, or servicing the product.

WARNING

Lockout the main gas shutoff valve before maintenance or inspection of the air heater.

WARNING

Guards and covers that prevent contact with electrically energized or moving parts are required and must not be removed or left open during operation.

WARNING

Welding, cutting, and other spark-producing operations shall not be permitted in or adjacent to a booth until a written permit authorizing such work has been issued. The permit shall be issued by a person in authority following his or her inspection of the area to ensure that precautions have been taken and will be followed until the job is completed.

WARNING

Local fire and building codes require fire protection. Check with local inspector authorities for requirements.

CAUTION

Read and save these instructions before attempting to assemble, install, operate, or maintain the product described. Protect yourself and others by observing all safety information. Failure to comply with instructions could result in personal injury and/or property damage. Retain these instructions for future reference.

CAUTION

This manual contains statements that relate to worker safety. Read this manual thoroughly and comply as directed. Operate this equipment in accordance with the guidelines set forth in this manual. It is impossible to list all potential hazards of this equipment. Instruct all personnel involved with this equipment in the safe conduct and operation of the system. GFS recommends that only qualified personnel operate and maintain this equipment.

CAUTION

Safety signs, panels, and labels that are normally affixed to the product must be replaced immediately if illegible or missing.

CAUTION

New or replacement parts that are installed during repair or maintenance must include all safety signs, panels, and labels as specified by the manufacturer. These must be affixed to the new or replacement parts as specified by the manufacturer.

CAUTION

Where applicable, use earplugs or take other safety measures for hearing protection.

NOTICE

The product must be installed and serviced only by a trained, qualified service technician. Incorrect installation may void the warranty.

NOTICE

If you have questions about the warranty, please contact your distributor prior to contacting GFS.

Booth safety

DANGER

Ceiling panel load capacity for installation and maintenance: You must use temporary platforms that span at least two structural frames for maintenance. **Do not walk on or apply any pressure to lights or explosion (deflagration) relief panels.**

WARNING

All equipment must be operated and maintained in accordance with local, state, and federal (OSHA) requirements governing occupational safety, fire protection, and booth operations. Operators must read and understand GFS and included independent equipment and/or component manufacturer's instructions prior to use. **Disclaimer:** GFS is not responsible for any injury, illness, or property damage that results from not abiding by local, state, or federal (OSHA) requirements that govern occupational safety, fire protection, and booth operations. GFS is also not responsible for any injury, illness, or property damage that is the result of not adhering to GFS and/or independent equipment/component operating, service, maintenance, and/or installation requirement's or directives.

WARNING

Install the booth in compliance with locally enforced codes and standards.

WARNING

A fire suppression system is required by the International Fire Code and NFPA 33. A fire suppression system is not supplied with this booth.

WARNING

Do not allow overspray to accumulate on the inside of the paint booth walls. When overspray accumulates, remove it as soon as possible to prevent a possible fire hazard. Use a non-ferrous, non-sparking scraper to eliminate any possibilities of igniting combustible material.

WARNING

Do not leave piles of paint sweepings in the booth as it creates a possible fire hazard.

WARNING

Treat used filters and any other paint-contaminated items as flammable products and dispose of them safely.

WARNING

If coatings containing nitrocellulose are sprayed in the booth, all residue must be removed from exhaust diffuser components and all exhaust filters must be changed at least once a day.

WARNING

Improper disposal of used filters may cause spontaneous combustion. You must consult local authorities for proper storage and disposal requirements. Guidelines include:

- Immediately remove all contaminated filters from the paint booth.
- Discard filters to a safe, detached location, place them in a non-combustible container with tight-fitting lid, or place them in a water-filled metal container to prevent a possible fire hazard.
- Disposal varies depending on the type of paint that is being captured. Consult local authorities for storage and disposal requirements.

WARNING

Duct the exhaust air from the fan away from the working environment to the outdoors. Do not operate the booth unless exhaust has been ducted properly.

WARNING

Isolate the outdoor vent from air-conditioning intakes, windows, and any other equipment that may re-circulate the exhaust indoors.

WARNING

Turn on the exhaust fan before using the spray booth. Ensure that the exhaust fan is operating correctly before entering the booth.

WARNING

Check local codes to see if a booth interlock is required. A booth interlock prevents the spray devices from operating unless the exhaust fan is operating.

WARNING

Some spray activities may require the use of respiratory protection.

WARNING

Use an OSHA-approved paint spray respirator when spraying in the booth.

WARNING

This equipment is designed for the removal of particulate matter only. Reduction of volatile organic compounds (VOCs) requires either coating reformulation or optional, additional equipment.

CAUTION

Become familiar with all controls before operating or servicing this booth.

CAUTION

Proper door alignment is critical to the operation of the booth. Ensure that there is equal space around the doors. Move the bottom of the door jamb to the left or right or in and out until the doors are sealed and plumb.

CAUTION

If this installation includes pumps or compressors, install and connect those devices in accordance with the manufacturer's documentation.

NOTICE

GFS recommends storing crates indoors pending installation. If you must store crates outside, protect crates and their contents from moisture to prevent damage to equipment.

NOTICE

Install the control panel per NFPA 70 and local codes and standards.

NOTICE

Failure to anchor the booth structure to the floor properly may result in structural damage.

Booth description

GFS' Ultra Paint Booth line provides a premium, high-performance finishing environment for body shops and collision centers.

The semi-downdraft booth is a hybrid, combining features of both crossdraft and downdraft booths. Air is introduced to the working area through the ceiling in the first 25 to 30 percent of the booth. It is then pulled across the working area, over the product, and into the filtered exhaust chamber at the rear of the booth.

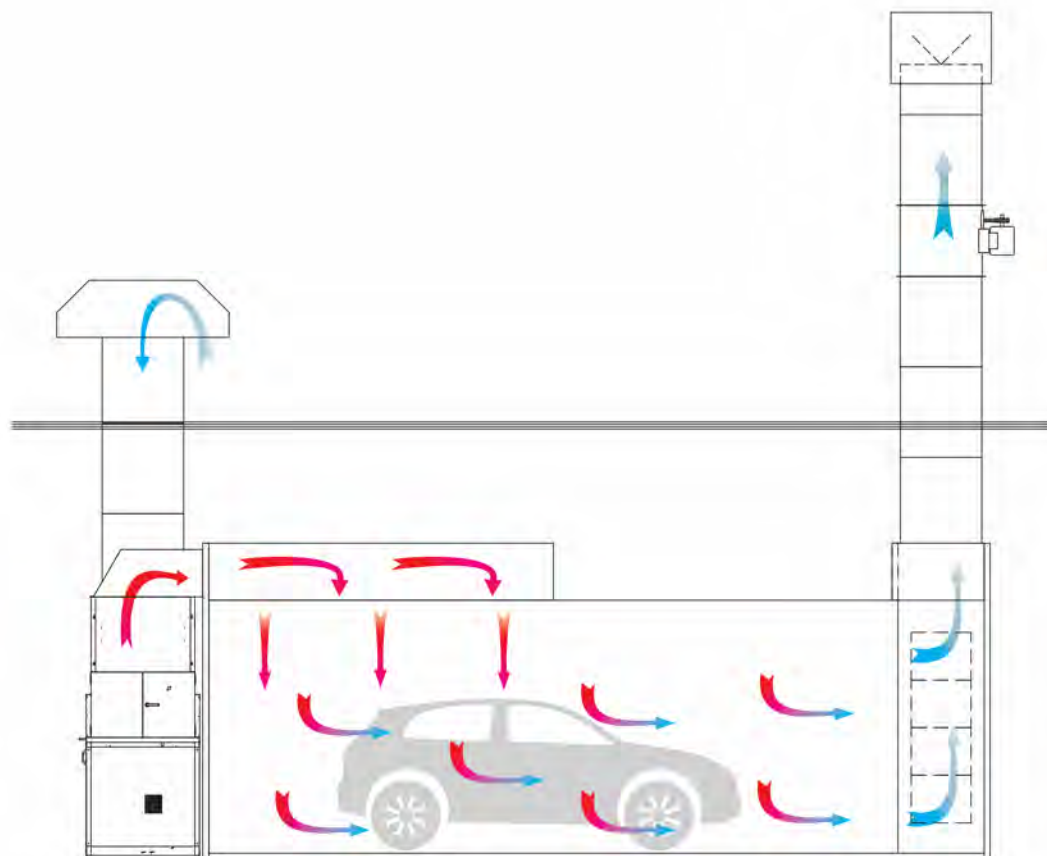

Figure 1. Airflow in a semi-downdraft booth with a BT air heater

Preparing for installation

Accepting delivery of your booth

The booth is delivered unassembled, in multiple crates.

Upon delivery, count the number of crates you received and compare that number to the expected number per the Bill of Lading. Also inspect each crate for any signs of damage during shipment.

NOTE

If you see shipping damage, note it on the freight carrier's paperwork; failure to do so may result in claim denial.

If any parts are missing or damaged, contact Global Finishing Solutions at 800-848-8738 to speak to a Technical Service Representative.

NOTICE

GFS recommends storing crates indoors pending installation. If you must store crates outside, protect crates and their contents from moisture to prevent damage to equipment.

Gathering required documentation

Ensure that you can locate these documents and that they are available during the installation procedure.

NOTE

Certain manuals, project drawings, and the Job-Specific Guide are also provided electronically to distributors via box.com. Many manuals are available for download on globalfinishing.com.

Table 3. Additional documentation

Document	Description	How provided
Design Drawings	Provides instructions for assembling this particular booth and includes information about the booth order, configuration, and components.	Ships in the “Miscellaneous” box
Electrical Drawings	Provides wiring diagrams for electrical components.	Ships inside the air heater control panel
Control Panel Operator Manual	Setup and operation instructions for the appropriate control panel: <ul style="list-style-type: none"> • Engage® Control Panel Operator Manual • LOGIC 3 Control Panel Operator Manual • LOGIC 4 Control Panel Operator Manual 	Ships inside the air heater control panel
<i>If applicable:</i> Air heater owner’s manual	Installation, operation, and maintenance instructions for the air heater; either: <ul style="list-style-type: none"> • GUL/BT Series Owner’s Manual (for GUL and BT air heaters) • SpaceSaver® Series Owner’s Manual 	Ships inside the air heater control panel
Final Commissioning Document (D0420)	Includes all tasks related to booth startup and commissioning.	Ships inside the air heater control panel

Confirming site requirements

Before beginning the installation procedure, confirm that the site where the equipment will be assembled meets the following requirements:

- The floor where you will assemble the paint booth is level.

NOTE

If the floor is more than 1 inch out of level, you must shim or grout the floor to avoid any misalignment.

- The area is large enough to allow a minimum of 3 feet (914 mm) of clear space on all four sides of the booth, taking into account if additional space is needed for an air heater or Air Make-Up Unit. Check local codes and refer to NFPA guidelines to determine particular space allowances.
- There is sufficient overhead clearance for an exhaust unit and the exhaust ductwork in the area where the equipment is to be located.
- A licensed electrician has verified that the incoming power meets the requirements specified for the equipment. (The power specification is included with the submittal or provided at delivery.)
- The appropriate devices for lifting/rigging are available onsite. (Either purchased from GFS with the booth, or obtained elsewhere by the customer.)
- The appropriate miscellaneous hardware kits are available on-site. (Either purchased from GFS with the equipment, or obtained elsewhere by the customer.)

Confirming booth layout

Before beginning the installation procedure, review the booth configuration and layout with the end user. Be sure you understand what options this booth includes and how the end user wants to arrange the booth.

The GA page of the Design Drawings shows one *possible* booth layout. However, end users might want their booths arranged differently. **During installation, you must make the appropriate adjustments to the instructions to accommodate the actual booth layout.**

For best results, review the GA page of the Design Drawings drawing with the end user and discuss the items listed below:

- Where does the end user want to place the air heater? (See Table 4.)
 - Right side, toward front of booth
 - Left side, toward front of booth
- Is this booth a drive-through booth (a booth with a product door on each end) or a solid-back booth?
- For a drive-through booth:
 - Is the front product door a 3-slab door or 4-slab door?
 - Is the rear product door a 3-slab door or 4-slab door?
- Where does the end user want to locate the personnel door?
 - On the left or right side of booth?
 - At which panel position?

- Where does the end user want to place the operator interface terminal/HMI?

NOTE

Per NEC, the operator interface terminal cannot be located within 3 feet of any door opening. Refer to the HMI Installation page of the Design Drawings for more information about placement restrictions.

- On an exterior booth wall? (If so, specify which.)
- On a nearby wall? (If so, determine distance and orientation relative to booth.)
- Within the booth’s interior, how does the end user want to arrange the wall lights?
- If the booth includes standard options and accessories, where should those items be located? (Examples include additional light fixtures, rotating access tables, observation windows, parts hangers, additional personnel doors, etc.)

Table 4. Air heater positions

Air heater position relative to booth		
Layout ¹	Description	
Right-front ²	Right side, toward front of booth	
Left-front	Left side, toward front of booth	

¹Air heater position is defined by the booth wall to which the heater connects (left side wall, right side wall, or back wall). When the air heater connects to the left or right side wall, the description also indicates whether the air heater is closer to the front or back of the booth.

²The “right-front” air heater position is the default layout depicted on the GA page of the Design Drawings.

About the Design Drawings document

Use this manual in conjunction with the provided Design Drawings document. This Design Drawings document defines the overall layout and detailed structure of your particular booth. If applicable, it also includes exploded-view diagrams and parts lists for each section (or subassembly) of the booth.

Page elements

Pages within the Design Drawings document contain the following elements:

- **Title block:** The title block is located along the right edge of each page. It contains the model information, drawing identification label or number, the order/serial number, and other information.
- **Model Info:** Contains text that identifies each page within the Design Drawings document, e.g., "Overall Assembly". When the installation instructions refer you to a specific page within the Design Drawings, look for that text in the Model Info field. (For a description of the various page types that might be included in your Design Drawings document, see "Page types" (page 19).)
- **Scale:** If the drawing is to scale, the scale is defined here (e.g., 3/16" = 1' 0"). Otherwise, this field contains "NTS," or "Not to Scale."
- **Drawings:** The main area of each page can contain any or all of these types of drawings:
 - An exploded and/or assembled view of the product or subassembly
 - Additional views or "Detail" drawings
- **Bill of Materials:** Any page that includes a drawing with labeled parts also includes a table that lists each item number with its corresponding part number and quantity.
- **Quantity per Booth:** Pages that show a subassembly of the product and list the quantity provided of that particular subassembly.
- **Notes:** Pages within the Design Drawings often contain notes that provide information about how to install that particular section or subassembly.

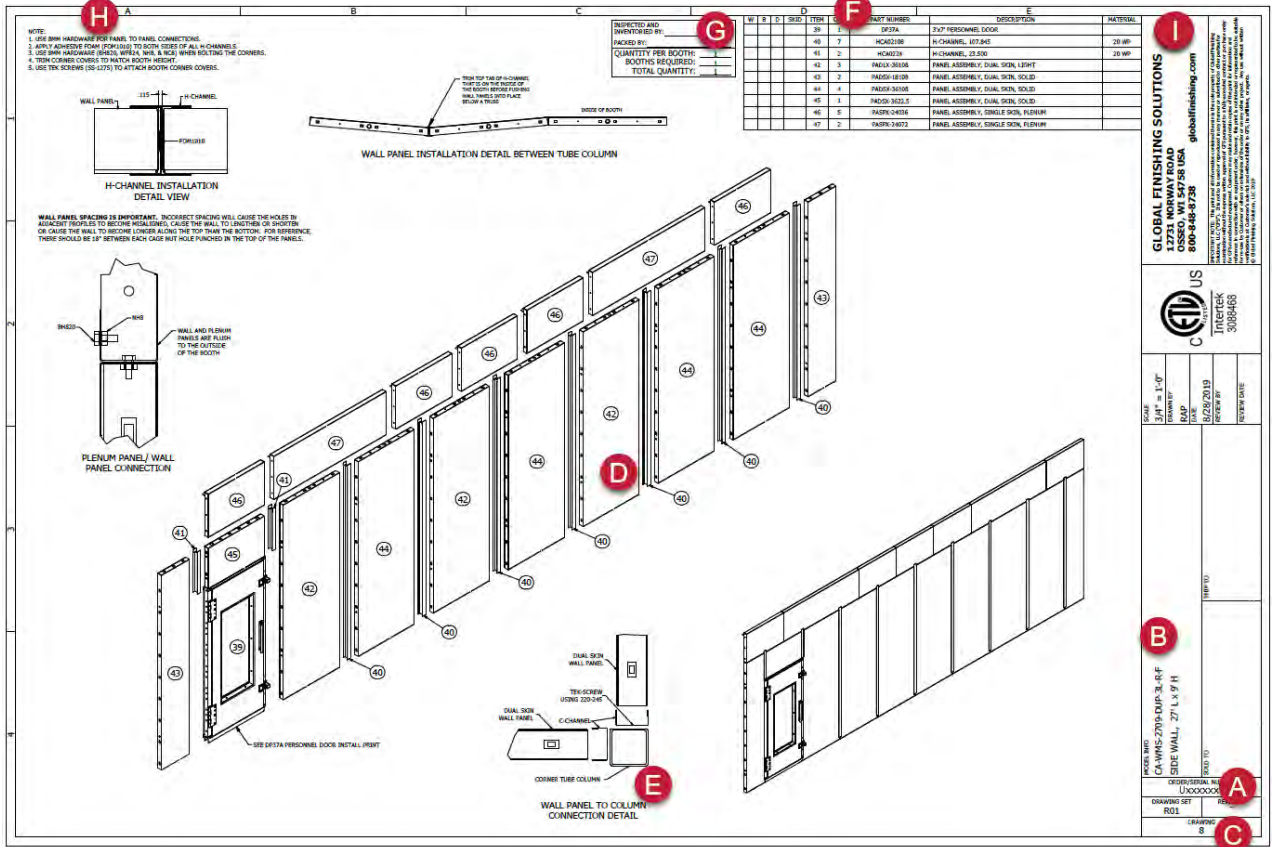

- A:** Serial number
- B:** Model info
- C:** Drawing number
- D:** Drawings: Main view (exploded and/or assembled)
- E:** Drawings: Detail view
- F:** Bill of materials
- G:** Quantity per booth
- H:** Notes
- I:** Title block

Page types

The Design Drawings document may contain any of the following pages that apply to your particular product.

Table 5. Page names in the Design Drawings document

Page name	Description
AdvanceCure	Provides instructions for installing the optional GFS AdvanceCure System. NOTE This page applies only to booths that include AdvanceCure.
AdvanceCure Intake & Discharge Cover Kit	Shows how to install cover plates at locations where the optional GFS AdvanceCure System integrates with the booth. NOTE This page applies only to booths that do not include the AdvanceCure.
Air Heater	Provides instructions for installing the air heater base and burner.
Air Inlet Hood	Shows how to assemble the air inlet hood that goes on top of the intake stack.
Basement Ramp Assembly	Shows how to assemble vehicle ramps. NOTE This page applies only to downdraft booths that use a raised basement instead of a traditional pit.
Booth Caulking Guide	Provides instructions for applying caulk to the booth.
Corner Light Harness	Shows how to run the wire harness cables to the optional corner light from the control panel.
Corner Light Installation	Shows how to install optional corner lights.
Diffuser Assembly	Shows how to install the diffuser for an air heater with side-entry into the booth plenum.
Discharge Hood Assembly	Shows how to assemble the discharge hood that connects the air heater to the booth plenum. NOTE This page applies only to booths that have a BT or GUL air heater.
Door Frame	Shows how to install a product door frame. NOTE A Door Frame page is classified as “3 Slab Door” or “4 Slab Door,” depending on the type of product door that will be installed in that frame. NOTE If a particular door frame adjoins an exhaust yoke, that Door Frame page is further denoted as “TL-Y” (versus “TL” for a door frame that does not adjoin an exhaust yoke).
Door Slab	Shows how to install a product door and its associated hardware. NOTE A Door Slab page is classified as “3 Doors” or “4 Doors,” depending on how many door slabs comprise that product door.
Exhaust Yoke	Shows an exploded view of the exhaust yoke located at the rear of the booth. NOTE This page applies only to semi-downdraft booths.
Filter Ceiling	Shows how to install the filter ceiling.
Floor Profile	Shows how to install the floor channel and floor-leveling components.
Floor Profile Tek-Screw Detail	Shows how to secure the wall panels to the floor profile.

Page name	Description
Front Wall	<p>Shows an exploded view of a drive-through end wall (a wall that accepts a product door).</p> <p>NOTE A Front Wall assembly is always installed at the front of the booth. For drive-through booths (which have a product door at each end), a Front Wall assembly is <i>also</i> installed at the rear of the booth.</p> <p>NOTE A Front Wall page is classified as “3 Slab Door” or “4 Slab Door,” depending on the type of product door that will be installed at that end.</p>
GA	<p>Provides a top view of the booth as well as front, side, and rear elevations.</p> <p>NOTE The GA page shows the standard booth arrangement and is provided for reference only; it is <i>not</i> customized for the booth you are building.</p> <p>NOTE The actual placement of some components (such as the air heater, personnel door, wall lights, etc.) might be different than shown on this page. Always consult with the end user for placement details, as described in “Confirming booth layout” (page 15).</p>
Hip Panels	<p>Shows how to install the hip light panels.</p> <p>NOTE This page applies only to semi-downdraft booths.</p>
HMI Installation	<p>Provides instructions for installing the operator interface terminal.</p>
Locking Rod	<p>Shows how to install the locking rod assembly for product doors.</p>
Label Placement Instructions	<p>Shows where to place various booth labels, including exit, maintenance, and safety labels.</p>
Light Fixture Details	<p>Shows how to install booth lights.</p>
Overall Assembly	<p>Shows an exploded view of the entire booth; identifies the major components and sub-assemblies of the booth.</p>
Personnel Door	<p>Shows how to install a personnel door and its associated hardware.</p>
Rear Wall	<p>Shows an exploded view of a solid end wall.</p> <p>NOTE This page applies only to booths that are not drive-through booths.</p>
Recirc Duct Assembly	<p>Shows how to assemble and install the ductwork that goes between a recirc air heater and the exhaust yoke.</p>
Reflector Light Fixture	<p>Shows how to install the optional light-reflector kit.</p>
Roof Panels	<p>Shows how to install the roof panels.</p>
Roof Support Assembly	<p>Shows how to install the roof support assembly.</p>
Side Wall	<p>Shows an exploded view of a side wall.</p> <p>NOTE The Design Drawings always contains two Side Wall pages: one that includes a personnel door, and one that does not include a door.</p>
Temp Sensor & Diffuser/Baffle	<p>Provides instructions for installing the temperature sensor and a diffuser (for an air heater with side-discharge into the booth) or a baffle (for an air heater with down-discharge into the booth).</p>
Wire Harness	<p>Shows how to run the wire harness cables for the lights to the air heater control panel.</p>

Required materials

This section lists the tools, equipment, and documentation required for installing your booth.

NOTE

Depending on the type of equipment you are installing, additional tools may be required.

Required tools

- Screwdrivers
- Wrenches and socket set
- Hammer and mallet
- Load bar that can extend to at least 9 feet (108 inches)
- Filter-insertion tool (metal pizza cutter; approximately 3-inch to 4-inch diameter)
- Drift pins (two per person; 1/8-inch to 5/8-inch taper)
- Caulk gun
- Impact driver and drill
- Unibit or step drill bits
- Chalk and/or felt-tip marker (for marking initial measurements on floor)
- Chalk-line tool
- 4-foot box level
- Laser level (*Suggested:* Quad laser or rotary laser level)
- Tape measures (35-foot and 100-foot)
- Tin snips
- Duct crimping tool
- Torque nut runner
- Reciprocating saw
- *Optional:* Torch and welder in case modifications need to be made on site
- Tools required for decal placement:
 - Stiff squeegee
 - Spray bottle with soapy-water mixture
 - Paper towels
 - Scissors
 - Masking tape
 - Marker

Recommended equipment

- Ladders (6-foot and 8-foot)
- Two or more sawhorses
- Two 26-foot T scissor-lift platforms
- Warehouse forklift with 5000-pound lift weight and a maximum lift height higher than 16 feet

NOTE

Lifts and cranes are not required, but they may improve both the safety and speed of installation.

NOTE

The end user is responsible for providing any lifts, cranes, and material handlers. Alternatively, the end user can coordinate with the installer so the installer can rent those items before starting the work.

Installation best practices

Unpack in stages

As you begin each section of the installation procedure, unpack the crate(s) that contain the parts for that section. In general, the skids are organized so the parts that go together during assembly are packed on the same skid.

NOTE

For faster unpacking, use a reciprocating saw to cut the crates.



Figure 2. Skids awaiting unpacking

A packing list is attached to each crate. As you unpack a crate, compare all the parts with that crate's packing list to check for shortages or losses in transit. Also check parts for any damage that might have been caused in shipping.

NOTE

Slightly bent panels and angle braces can be straightened and will cause no performance or assembly problems.

If any parts are missing or damaged, contact Global Finishing Solutions at 800-848-8738 to speak to a Technical Service Representative.

Sort parts by size

To help installation proceed more efficiently, sort all parts by size as you unpack them (Figure 3).

Each part has a specific part number. The part number is either etched into the part or printed on a label affixed to the part (Figure 4).



Figure 3. Panels sorted by size in preparation for assembly

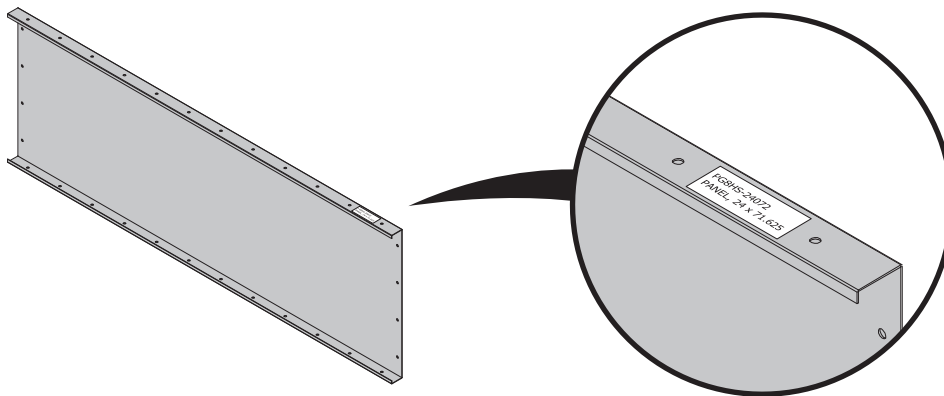

Figure 4. Example of a part number label

Remove protective coating

Some booth parts ship with a protective coating. For efficiency during installation:

- Remove the part number label from the part and set the label aside temporarily.
- Remove the blue protective coating from the part.
- Re-apply the part number label on the part. (Use tape to affix the label to the part, if necessary.)

Follow assembly guidelines

Follow these guidelines when assembling the booth:

- Assemble the booth in sections, following the sequence provided in this document.
- As you build each section, tighten the bolts only to finger-tight.
- Before tightening the bolts within a section, confirm that the section is plumb and square.
- When directed to do so, tighten the bolts within a section to *snug-tight*. Snug-tight is defined as “the tightness that is attained with a few impacts of an impact wrench or the full effort of an ironworker using an ordinary spud wrench to bring the plies into firm contact.” (RCSC 2014)
- **For dual-skin booths:** Orient panels and parts as shown on the assembly drawings.
- **For single-skin booths:** Orient panels so that each panel’s flanged side faces outward, and the non-flanged side faces the booth’s interior.
- **For all booths:** When applicable, orient bolts so that the bolt heads (and a washer) are on the booth’s interior and the threads are on the exterior.
- Use hardware as specified on the assembly drawings.
- Plumb the panels so that they are perpendicular to the floor. The sides of the booth must be parallel to each other.

Installation procedure

This procedure describes how to install an Ultra XD, or XS booth with a BT air heater.

Prepare the floor

Mark the booth footprint

Reference: Refer to the Floor Profile page of the Design Drawings.

1. Sweep the floor clear of debris.
2. Use a laser level to check the floor:
 - If the floor is out of level by **1 inch or less** over the full length of the booth, continue to the next step. (You do not need to take any corrective action now because you will be able to correct for slope when you install the floor leveling components later in the procedure.)
 - If the floor is **more than 1 inch** out of level over the full length of the booth, shim or grout the floor as needed to get it to within 1 inch of level. GFS does not provide shims.
3. Referring to the **Inside-to-Inside Width** and the **Inside-to-Inside Length** shown on the Floor Profile page of the Design Drawings, measure the booth's footprint on the floor and mark the corners.

NOTE

Ensure that the location allows for the clearances around the booth as specified in "Confirming site requirements" (page 15).

NOTE

Use a piece of chalk or other temporary mark at this stage, in case you have to adjust the position of the marks in the next step.

4. Measure the diagonals to confirm that the opposite sides are parallel and that adjacent sides are perpendicular to each other.

Re-measure and adjust the corner markings as needed until the diagonals are equal length.

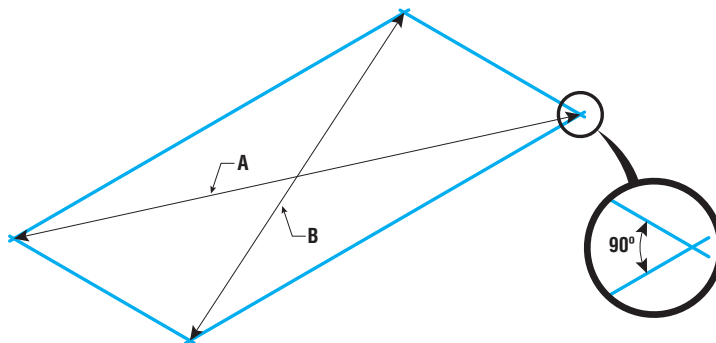

5. After confirming that the measurements are correct and the angles are 90 degrees, snap chalk lines to mark the outline of the booth's footprint.

Mark the air heater footprint

Prerequisites: The booth footprint must already be marked on the floor as described in “Mark the booth footprint” (page 26).

NOTE

The location where the air heater is placed must meet the following requirements:

- Follows end user’s preference for the position of the air heater relative to the booth (either right-front or left-front), as described in “Confirming booth layout” (page 15).
- Provides the required distance between the air heater and the inner edge of the floor channel (from the Air Heater Placement detail on the Air Heater page of the Design Drawings)
- Provides the required minimum clearances around the air heater (from the Plan View on the GA page of the Design Drawings)

Reference: Refer to the Air Heater page of the Design Drawings.

1. Identify a location that meets the requirements listed above; then measure the air heater's footprint on the floor and mark the corners.

NOTE

The air heater dimensions are provided on the Air Heater page of the Design Drawings.

NOTE

Use a piece of chalk or other temporary mark at this stage, in case you have to adjust the position of the marks in the next step.

2. Measure the diagonals to confirm that the opposite sides are parallel and that adjacent sides are perpendicular to each other.

Re-measure and adjust the corner markings as needed until the diagonals are equal length.

3. Snap chalk lines to mark the outline of the air heater.

Install the BT air heater

Prerequisites: The air heater footprint must already be marked on the floor as described in “Mark the air heater footprint” (page 27).

Reference:

- Refer to the Air Heater page of the Design Drawings while completing this task.
- Refer to the air heater’s owner manual for additional installation, operation, maintenance, and safety information.

1. Place the air heater’s base section in its designated position (denoted by the air heater footprint marked on the floor).

NOTE

Be sure to orient the base appropriately for the intended booth layout.

2. Ensure that the base section is level front-to-back and side-to-side.
3. Build the discharge hood as directed on the Discharge Hood Assembly page of the Design Drawings.
4. Place the assembled discharge hood on top of the air heater's burner section and bolt it into position.
5. Place the burner section (with discharge hood assembly installed) on top of the base and bolt it into position.

If necessary: Install the intake stack now

Scope: This task applies only if the site's layout will make it difficult to access the air heater after the booth is assembled. If you will have easy access to the air heater after the booth is built, skip this task and continue to task 4.

NOTE

A site's physical layout might make it difficult to access the air heater after the booth is assembled. In such cases, you should install the intake stack now, before you build the rest of the booth. Otherwise, some booth components will be in the way when you build the intake stack.

Jump ahead in the procedure to "Assemble the intake stack" (page 42) and follow the directions there to install the intake stack; then resume the procedure from this point.

NOTE

An end user who is installing the optional guy-wire kit on the intake stack can proceed with that work as soon as you have completed the full stack. See "*If applicable: Install the guy-wire kit*" (page 45) for more information.

Install the floor channel

Prerequisites: The air heater must already be installed.

Reference: Refer to the Floor Profile page of the Design Drawings.

1. Install the floor outer profiles.

NOTE

If necessary, grout and shim the floor outer profiles to ensure that they are not more than 1 inch out of level. GFS does not supply shims.

2. Anchor the floor outer profiles to the building floor.

NOTE

GFS does not provide the anchors.

3. Install and level the panel leveling profiles.

Assemble the walls for the front section of the booth

Prerequisites: The floor channels must already be installed and leveled as directed in "Install the floor channel" (page 28).

NOTE

In this task, the term “front section of the booth” refers to the portion of the booth that has a plenum.

IMPORTANT

The drawings on the GA page of the Design Drawings page show one possible booth layout. However, the end user might want to arrange the booth differently than shown. **Be sure you understand how this particular booth is to be arranged.** For more information, see “Confirming booth layout” (page 15).

Build the front section of the side wall that connects to the air heater

Reference: Refer to the Side Wall page of the Design Drawings.

NOTE

The Design Drawings contain two Side Wall pages: one that includes a personnel door, and one without a personnel door. Use the appropriate page depending on whether the particular side wall you are building includes a personnel door or not.

NOTE

When building a wall that includes a door, use the Side Wall page of the Design Drawings (with personnel door) as a guide, but adjust the position of the door depending on where the end user wants the door located. The personnel door can be swapped with any 36-inch vertical side-wall panel. Install any panels and channels that frame the door, but **do not hang the door or install any door hardware during this step.**

NOTE

Build the side wall in sections, with each section consisting of a few vertical panels and the horizontal plenum panel that spans them. In this task, you will build one wall section for a 24-foot booth, or two wall sections for a 27- or 30-foot booth.

1. Starting from the front end of the wall, install the side panels (and adjacent channels, if applicable) that will fit under the first plenum panel.

NOTE

Channels are applicable only for dual-skin booths.

2. **For single-skin booths:** Install a tie angle above that group of side panels.
3. Install a plenum panel above that group of side panels:

NOTE

The air heater connects to the plenum through this panel, so you must cut the discharge opening as directed below.

- a. Install the plenum panel temporarily and mark the discharge opening. (For dimensions, refer to the Discharge Opening view on the Air Heater page of the Design Drawings.)
 - b. After marking the cutout, remove the panel and cut the hole for the discharge opening. (BE CAREFUL NOT TO CUT PLENUM PANEL STIFFENERS.)
 - c. Install the panel (with cutout) in the appropriate position.
4. **For a 27-foot or 30-foot booth:** Build the next section of wall:

NOTE

If you are building a 24-foot booth, skip this step and continue to “Build the front wall of the booth” (page 30).

- a. Install the side panels (and adjacent channels, if applicable) that will fit under the next plenum panel.

NOTE

Channels are applicable only for dual-skin booths.

- b. Install a horizontal plenum panel (and tie angle, if applicable) above that group of vertical wall panels.

NOTE

Tie angles are applicable only for single-skin booths.

Build the front wall of the booth

Scope: In Ultra booths, this task always applies to the front end wall. If this booth is a drive-through booth (that is, if it has a product door at both the front and rear of the booth), then this task also applies to the rear end wall.

Reference:

- For steps related to wall assembly, refer to the Rear Wall page of the Design Drawings.
- For steps related to the GFS Ultra decal, refer to the Label Placement Instructions page of the Design Drawings. Also see “Required tools” (page 21) for a list of tools required for decal placement.

IMPORTANT

For a drive-through booth, be aware of which end of the booth you are working at (front or rear). Refer to the Overall Assembly page of the Design Drawings to determine which front wall assembly should be used at that end of the booth. Then use the corresponding Front Wall page as you build that wall.

1. Install the end wall vertical panels and adjoining corner angles.

NOTE

Do not install the corner covers at this time. (You will install them later in the procedure; see “Install the corner covers” (page 42).)

2. Obtain the header panel and place it across two sawhorses with its exterior side facing up.
3. Inspect the header panel and ensure that it is clean.

NOTE

If necessary, spray the panel with soapy water and wipe it dry with a lint-free cloth.

4. Ensure that your hands are clean; then obtain the GFS Ultra decal from the Miscellaneous box.
5. Lightly fold the decal in half and create a slight indentation at the middle of the decal; then place masking tape to mark the middle of the decal.



6. Locate the center of the header panel; then use masking tape to temporarily secure the center of the decal to the center of the panel.

NOTE

Orient the decal so that it will be right-side up when the header panel is installed.

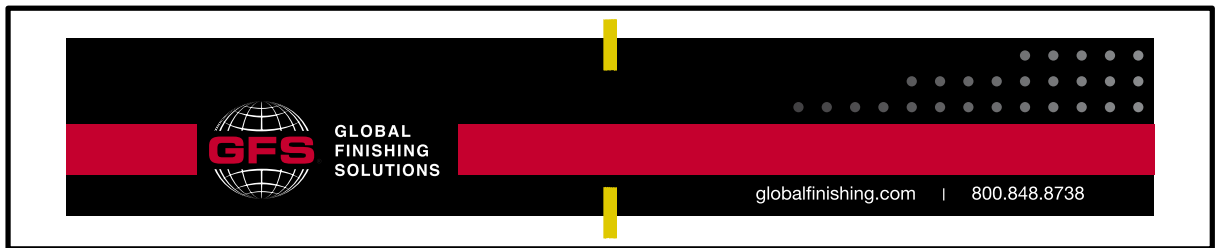

7. Pull back one side of the decal as far as possible (up to where the center of the decal is taped to the panel) and liberally spray the panel beneath with soapy water.

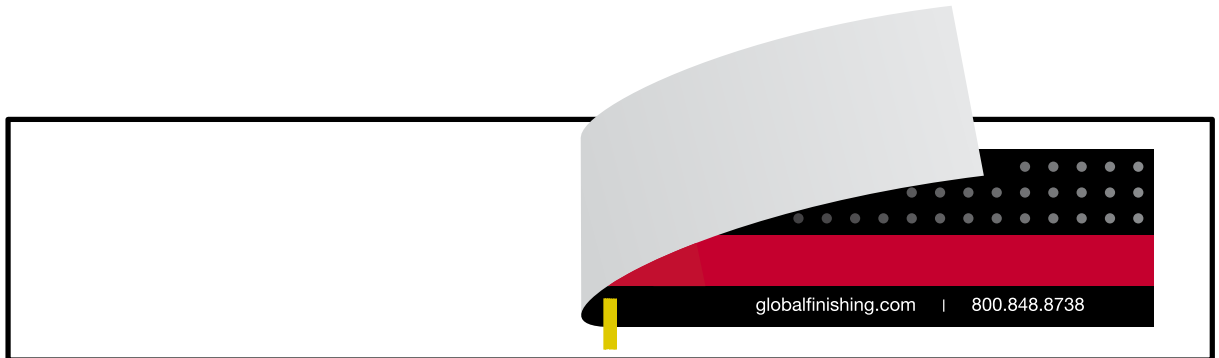

8. Create a starting point near the center of the decal for peeling off the backing:
 - a. Working as closely as possible to where the center of the decal is taped to the panel, carefully separate the backing from the decal.
 - b. Cut or tear the backing across the height of the decal (in as straight a line as possible) to make a starting point for peeling.



9. Grasp the cut (or torn) edge of the backing paper for the side of the decal that is folded back; then begin peeling off the backing paper as you lay the folded-over half of the decal back onto the panel. Every few inches, use the plastic squeegee to remove wrinkles and air bubbles. Continue peeling off the backing and smoothing the decal onto the panel with the squeegee until that half of the decal is fully applied.

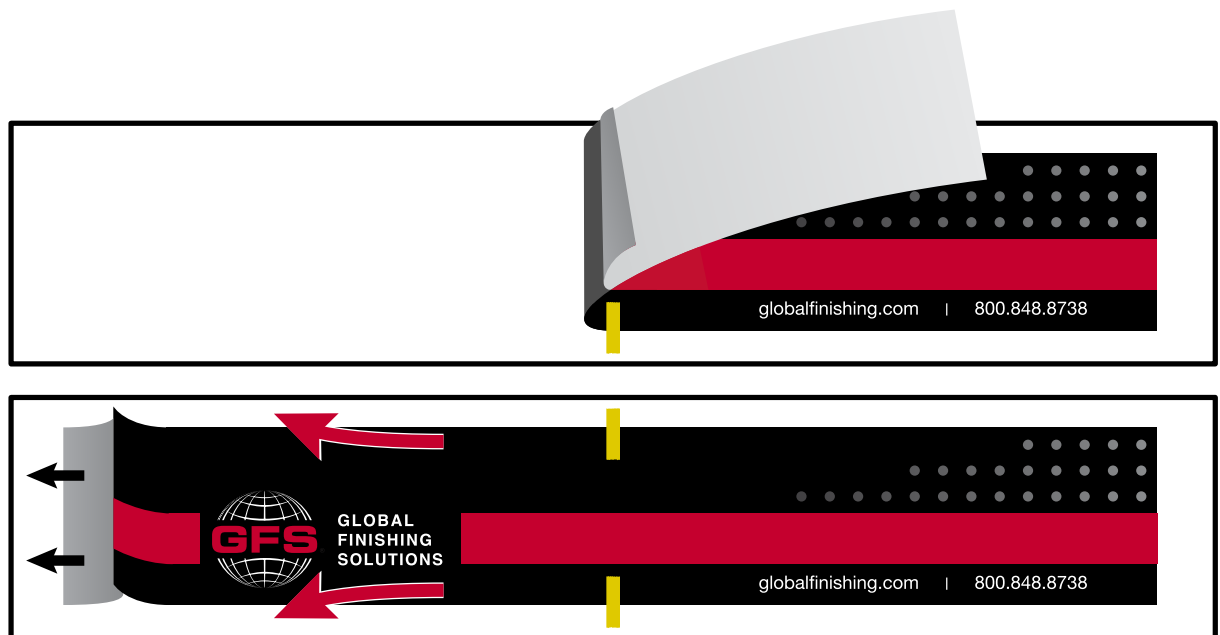

10. Remove the masking tape from the decal.
11. Affix the other half of the decal to the panel:
 - a. Pull back the other side of the decal as far as possible (up to where the first side is affixed to the panel).
 - b. Liberally spray the panel beneath the folded-back half with soapy water.
 - c. Repeat step 9 for this half of the decal.
12. Wipe off any excess water from the decal and panel.
13. Install the header panel (with decal already applied).

NOTE

Ensure that the GFS Ultra decal faces the booth's exterior.

NOTE

After installing the panel, double-check for hand prints or smudges; clean the panel, if necessary.

14. Install the frontal roof support that spans the header panel and the vertical panels.
15. Ensure that the completed wall is plumb, square, and level.
16. Tighten all bolts in the wall to snug-tight.

Build the front section of the opposite side wall

Prerequisites: The front wall must already be installed as described in “Build the front wall of the booth” (page 30).

Reference: Refer to the Side Wall page of the Design Drawings.

NOTE

The Design Drawings contain two Side Wall pages: one that includes a personnel door, and one without a personnel door. Use the appropriate page depending on whether the particular side wall you are building includes a personnel door or not.

NOTE

When building a wall that includes a door, use the Side Wall page of the Design Drawings (with personnel door) as a guide, but adjust the position of the door depending on where the end user wants the door located. The personnel door can be swapped with any 36-inch vertical side-wall panel. Install any panels and channels that frame the door, but **do not hang the door or install any door hardware during this step.**

NOTE

Build the side wall in sections, with each section consisting of a few vertical panels and the horizontal plenum panel that spans them.

1. Starting from the front end of the wall, install the side panels (and adjacent channels, if applicable) that will fit under the first plenum panel.

NOTE

Channels are applicable only for dual-skin booths.

2. Install a horizontal plenum panel (and tie angle, if applicable) above that group of vertical wall panels.

NOTE

Tie angles are applicable only for single-skin booths.

3. **For a 27-foot or 30-foot booth:** Repeat step 1 and step 2 to build the next section of wall.

NOTE

If you are building a 24-foot booth, skip this step and continue to “Install the plenum end panel” (page 33).

Install the plenum end panel

Prerequisites:

- **For a 24-foot booth:** The first section of each side wall must already be assembled.
- **For a 27- or 30-foot booth:** The first two sections of each side wall must already be assembled.

Reference:

- To identify the plenum end panel, refer to the Roof Panels page of the Design Drawings.
 - For connection details, refer to the Plenum Panel/Wall Panel Connection view on the Side Wall page of the Design Drawings.
1. Lift the plenum end panel into position between the side walls of the booth.
 2. Bolt the plenum end panel to a plenum panel on the left and right side walls.
 - **For a 24-foot booth:** The plenum end panel connects to the bolt holes on the rear-most flange of the first plenum panel on each side wall.
 - **For a 27-foot or 30-foot booth:** The plenum end panel connects to the holes on the first stiffener of the second plenum panel (from the front) on each side wall.

Finish the side walls of the booth

Prerequisites: The plenum end panel must already be installed as directed in “Install the plenum end panel” (page 33).

Reference: Refer to the Side Wall page of the Design Drawings.

NOTE

The Design Drawings contain two Side Wall pages: one that includes a personnel door, and one without a personnel door. Use the appropriate page depending on whether the particular side wall you are building includes a personnel door or not.

NOTE

When building a wall that includes a door, use the Side Wall page of the Design Drawings (with personnel door) as a guide, but adjust the position of the door depending on where the end user wants the door located. The personnel door can be swapped with any 36-inch vertical side-wall panel. Install any panels and channels that frame the door, but **do not hang the door or install any door hardware during this step.**

NOTE

Build the side wall in sections, with each section consisting of a few vertical panels and the horizontal plenum panel that spans them.

1. **For dual-skin booths:** Finish building the side wall that connects to the air heater:
 - a. Install the vertical wall panels and adjacent channels that will fit under the next plenum panel.
 - b. Install a horizontal plenum panel above that group of vertical wall panels.
 - c. Working toward the back of the booth, continue installing the side wall in sections (a few vertical panels and channels; then the plenum panel that spans them) until the side wall is completed.
2. **For single-skin booths:** Finish building the side wall that connects to the air heater:

- a. Install the vertical wall panels that will fit under the next plenum panel.
 - b. Install a tie angle and horizontal plenum panel above that group of vertical wall panels.
 - c. Working toward the back of the booth, continue installing the side wall in sections (a few vertical panels and channels; then the plenum panel that spans them) until the side wall is completed.
3. Repeat step 1 or step 2 (as appropriate) to finish the opposite side wall.
 4. Ensure that the side walls are plumb, square, and level.
 5. Tighten all bolts in the side walls to snug-tight.

Build the back wall of the booth

Prerequisites: The side walls of the booth must be completed as described in “Finish the side walls of the booth” (page 34).

NOTE

Depending on the specific configuration for the booth, the back wall consists of either a solid wall or a product door. Refer to the Rear Elevation view on the GA page of the Design Drawings to determine which type of back wall is specified for this booth. Then proceed to the appropriate task to build either a solid end wall or drive-through end wall.

- **For a wall:** See “*If applicable: Build a solid end wall*” (page 35)
- **For a product door:** See “Build the front wall of the booth” (page 30)

If applicable: Build a solid end wall

Scope: This task applies only if the booth does not have a product door at the rear of the booth. If there is a product door at the rear, perform “Build the front wall of the booth” (page 30) instead of this task.

Reference: Refer to the Rear Wall page of the Design Drawings.

1. Install the vertical wall panels, the adjacent channels (if applicable), and the corner angles.

NOTE

Do not install the corner covers at this time. (You will install them later in the procedure; see “Install the corner covers” (page 42).)

NOTE

Channels are applicable only for dual-skin booths.

2. Install the horizontal header panel (and tie angles, if applicable) above the vertical wall panels.

NOTE

Tie angles are applicable only for single-skin booths.

3. Ensure that the completed wall is plumb, square, and level.
4. Tighten all bolts in the wall to snug-tight.

If applicable: Build a drive-through end wall

Prerequisites:

- The side walls must be completed as described in “Finish the side walls of the booth” (page 34).
- The truss cover panels and truss must already be installed.

Reference: Refer to the Rear Wall page of the Design Drawings.

1. Install the vertical wall panels and the adjacent channels (if applicable).

NOTE

Channels are applicable only for dual-skin booths.

2. Ensure that the completed wall is plumb, square, and level.
3. Tighten all bolts in the wall to snug-tight.

Assemble the exhaust yoke

Prerequisites: All four booths must already be assembled.

Reference: Refer to the Exhaust Yoke page of the Design Drawings.

1. Tek-screw each exhaust-yoke angle to the adjoining end-wall panel.

NOTE

Refer to the Chamber to Wall Connection Detail on the Exhaust Yoke page of the Design Drawings.

2. Tek-screw the front filter panels of the exhaust yoke to the adjoining side wall panels.
3. Bolt the side filter panels to the exhaust-yoke angles and to the front filter panels.
4. Lift the exhaust-yoke plenum end panel into place; then bolt the ends to the front filter panels and to the adjoining side wall panels.
5. Place and bolt together the fan panel and the roof panels.
6. Working from the left and right sides of the exhaust yoke toward the center, place and bolt the panels that form the floor of the exhaust-yoke plenum.
7. Apply the foam tape and install the access panel.
8. Ensure that the completed exhaust yoke is plumb, square, and level.
9. Tighten all bolts in the exhaust yoke to snug-tight.

Install the exhaust fan

Prerequisites: The exhaust yoke must already be installed as described in “Assemble the exhaust yoke” (page 36).

NOTE

This task also includes installation of the ductwork that runs from the exhaust-yoke fan plate to the exhaust fan.

NOTE

To connect duct sections together:

- Slip the bottom of one duct section into the top of the previous duct section.
- Ensure that the duct section is level north-south and east-west.
- Tek-screw the duct section to the previous duct section from the inside out.

NOTE

When placing the exhaust fan, observe the airflow and blade rotation indicators on the outside of the exhaust fan housing.

Reference: Refer to the diagram below and to the RH Side Elevation view on the GA page of the Design Drawings.

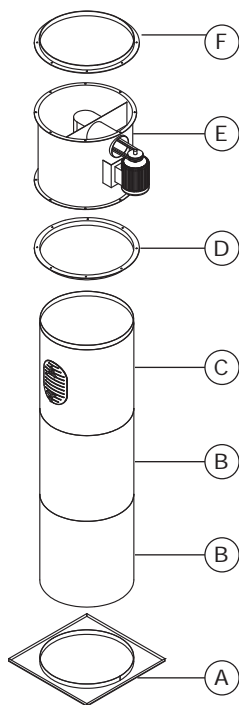

- A:** Exhaust-stack base plate
B: Plain duct section
C: Clean-out duct (plain duct section with clean-out door)
D: Fan ring (flange up; duct lip down)
E: Exhaust fan
F: Fan ring (flange down; duct lip up)

1. Install the first section of plain duct:
 - a. Place a plain duct section over the duct lip of the exhaust-stack base plate.
 - b. Ensure that the duct section is level north-south and east-west.
 - c. Tek-screw the duct section to the duct lip from the inside out.
2. Install the second section of plain duct.

NOTE

Follow the procedure for connecting duct sections together in the notes at the beginning of this task.

3. Connect the clean-out duct to the previous duct section.

NOTE

Follow the procedure for connecting duct sections together in the notes at the beginning of this task.

4. Connect a fan ring to the clean-out duct:
 - a. Orient the fan ring with the duct lip facing down and the flange facing up.
 - b. Slip the duct lip into the top of the clean-out duct.
 - c. Tek-screw the fan ring to the duct from the inside out.
5. Use a forklift to place the exhaust fan onto the fan ring, orienting the fan so that the fan motor points to the appropriate side of the booth.

NOTE

Refer to the GA page of the Design Drawings to see how the fan motor should be oriented relative to the booth.

6. Bolt the fan to the fan ring using 8-mm hardware (nuts, bolts, and washers).

NOTE

Tighten the bolts to finger-tight until they are all installed; then tighten them to snug-tight.

7. Connect another fan ring to the flange on the top of the exhaust fan.

NOTE

Orient this fan ring with its flange facing down and duct lip facing up. Bolt the fan ring to the fan as described in the previous step.

For roof height over 15 feet: Install the exhaust stack now

Scope: This task applies only if the building's roof height is **over 15 feet**. If the roof height is 15 feet or lower, skip this task.

NOTE

If the building's roof height is over 15 feet, you should install the exhaust stacks now, before you build the rest of the booth. Otherwise, some booth components will be in the way when you build the stacks.

Jump ahead in the procedure to "Assemble the exhaust stack" (page 43) and follow the directions there to install the exhaust stack; then resume the procedure from this point.

NOTE

An end user who is installing the optional guy-wire kit (on either or both stacks) can proceed with that work as soon as you have completed the full stacks. See "*If applicable: Install the guy-wire kit*" (page 45) for more information.

Assemble the top of the booth

Install the high roof panels

Prerequisites: The exhaust fan must already be installed as directed in "Install the exhaust fan" (page 36). If this building has a roof height over 15 feet, the exhaust stack must also be installed as directed in "*For roof height over 15 feet: Install the exhaust stack now*" (page 38).

NOTE

The “high roof panels” form the roof of the intake plenum. The plenum extends from the front wall of the booth to the plenum end panel (installed in “Install the plenum end panel” (page 33)).

NOTE

For booths with a recirc air heater, explosion relief is required for compliance with NFPA 33. Refer to the guidelines on the Roof Panels page of the Design Drawings.

Reference: Refer to the Roof Panels page of the Design Drawings.

Install the hip light panels

Prerequisites: The high roof panels (the intake plenum roof) must already be installed as described in “Install the high roof panels” (page 38).

NOTE

The hip light panels extend from the front wall of the booth to the exhaust yoke.

Reference: Refer to the Hip Panels page of the Design Drawings.

Install the roof support assembly

Prerequisites: The hip light panels must already be installed

Reference:

- To see the location of the roof support assembly relative to the rest of the booth, refer to the Overall Assembly page of the Design Drawings.
- For installation instructions, refer to the Roof Support Assembly page of the Design Drawings.

Install the filter ceiling

Prerequisites: The roof support assembly must be installed as directed in “Install the roof support assembly” (page 39).

NOTE

The filter ceiling extends the length of the plenum (that is, from the front wall to the plenum end panel).

NOTE

Do not install the filter racks or the intake filters during this step. You will be directed to do so later in the procedure (see “Install the filter racks and intake filters” (page 51)).

Reference: Refer to the Filter Ceiling of the Design Drawings.

Install the low roof panels

Prerequisites: The filter ceiling must already be installed as directed in “Install the filter ceiling” (page 39).

NOTE

The “low roof panels” form the roof in the rear section of the booth where there is no plenum. The “low roof” extends from the plenum end panel (installed in “Install the plenum end panel” (page 33)) to the exhaust yoke.

Reference: Refer to the Roof Panels page of the Design Drawings.

If applicable: Install the AdvanceCure system

Scope: This task applies only if this booth includes the GFS AdvanceCure System.

Prerequisites: The roof panels must already be installed.

Reference: Refer to the AdvanceCure pages of the Design Drawings. (The Design Drawings contain four pages, numbered “x.1” through “x.4,” where “x” is the overall sheet number for the print in this particular Design Drawings document. The sheet number is located in the lower right corner of the print.)

NOTE

Install the AdvanceCure filters during this task, as directed on the AdvanceCure “x.3” page of the Design Drawings.

If applicable: Install the AdvanceCure cover kit

Scope: This task applies only if this booth does not include the optional GFS AdvanceCure System.

Prerequisites: The roof panels must already be installed.

Reference: Refer to the AdvanceCure Intake & Discharge Cover Kit page of the Design Drawings.

Install the product door

Prerequisites: The filter ceiling must already be installed as directed in “Install the filter ceiling” (page 39).

Install the door frame

Reference: Refer to the Door Frame page of the Design Drawings.

IMPORTANT

For a drive-through booth, be aware of which end of the booth you are working at (front or rear). Refer to the Overall Assembly page of the Design Drawings to determine which door frame assembly should be used at that end of the booth. Then use the corresponding Door Frame page of the Design Drawings as you install the frame.

1. Install the floor profile for the door frame:
 - a. Find the high point on the floor within the “rough opening” area.
 - b. Set the floor profile for the door frame at that high point; then shim and grout the rest of the rough opening to that high point.

NOTE

GFS does not provide shims.

- c. Anchor the floor profile for the door frame.

NOTE

GFS does not provide the anchors.

2. Build the rest of the door frame (door posts, door frame support angles, and door header).

NOTE

Tighten bolts only to finger-tight.

3. Install the proximity sensor.
4. Ensure that the completed door frame is plumb, square, and level.
5. Tighten all bolts in the door frame to snug-tight.
6. Install the covers on the door floor profile, door posts, and door header.
7. Install the outer door hinges.

Install the locking rods and door hardware

Prerequisites: The door frame must already be installed as directed in “Install the door frame” (page 40).

NOTE

The number of locking rods required for a product door depends on the number of door slabs:

- A 3-slab door requires two locking rods.
- A 4-slab door requires three locking rods.

References:

- Refer to the Locking Rod page of the Design Drawings.
- Refer to the Door Slab page of the Design Drawings.

Install the door slabs

Prerequisites: The door frame and locking rods must already be installed.

Reference: Refer to the Door Slab page of the Design Drawings.

IMPORTANT

For a drive-through booth, be aware of which end of the booth you’re working at (front or rear). Refer to the Overall Assembly page of the Design Drawings to determine which door slab assembly should be used at that end of the booth. Then use the corresponding Door Slab page of the Design Drawings as you install the slabs.

Install the personnel door

Prerequisites: The side wall where the door will be located must already be installed (including door posts, door header, and threshold).

Reference: Refer to the Personnel Door page of the Design Drawings.

NOTE

For dual-skin booths: Read and follow the Dual Skin Installation notes on the Personnel Door page of the Design Drawings.

NOTE

For single-skin booths: Read and follow the Single Skin Installation notes on the Personnel Door page of the Design Drawings.

Install the corner covers

Prerequisites: All four booth walls must already be assembled.

Reference: Refer to the appropriate page of the Design Drawings depending on the type of end wall that adjoins each corner.

- **For a drive-through end wall:** Use the Front Wall page of the Design Drawings. If the booth is a drive-through booth, refer to the Overall Assembly page of the Design Drawings to determine which Front Wall assembly applies at each end of the booth.
- **For a solid end wall:** Use the Rear Wall page of the Design Drawings.

Install the diffuser assembly

Prerequisites: The booth walls must already be installed and the discharge opening must already be cut in the appropriate panel on the wall that connects to the heater.

Reference: Refer to the Diffuser Assembly page of the Design Drawings.

Install the intake and exhaust stacks

Scope: If you installed the intake and exhaust stack earlier in the procedure, skip this task and continue to “Install the lights” (page 45).

Assemble the intake stack

Prerequisites: The base section(s) of the air heater must already be installed as described in “Install the BT air heater” (page 27).

IMPORTANT

If the roof opening is already cut, install all intake ductwork (including the air inlet hood) during this step. If the roof opening is *not* cut, install the intake ductwork to just below the roof. (In that case, you will have to finish installing the rest of the ductwork later, after the roofer has cut the roof opening.)

NOTE

Per NFPA 33, the air inlet hood on top of the intake stack and the automatic roof ventilator (ARV) on top of the exhaust stack must be at least 10 feet away from each other.

NOTE

To connect duct sections together:

- Slip the bottom of one duct section into the top of the previous duct section.
- Ensure that the duct section is level north-south and east-west.
- Tek-screw the duct section to the previous duct section from the inside out.

Reference: Refer to the RH Side Elevation view on the GA page of the Design Drawings for the intake stack duct sequence.

1. Connect the first section of plain duct:
 - a. Place a section of plain duct over the intake opening on the base of the air heater.
 - b. Ensure that the duct section is level north-south and east-west.
 - c. Tek-screw the duct from the inside out.
2. *If applicable:* Continue connecting all necessary plain duct sections as required for the intake stack.

NOTE

Follow the procedure for connecting duct sections together in the notes at the beginning of this task.

3. Assemble the air inlet hood.

NOTE

For instructions, refer to the Air Inlet Hood page of the Design Drawings.

- a. Orient the base plate assembly with the duct lip facing down and insert it into the top section of plain duct.
 - b. Level the base plate square-to-round; then Tek-screw the base plate to the duct section from the inside out.
 - c. Assemble the two end panels and the top panel of the air inlet hood.
 - d. Install the two side panels on the air inlet hood.
 - e. Install the two screen panels on the air inlet hood.
 - f. Place the assembled hood onto the base plate and ensure that it is level north-south and east-west.
 - g. Bolt the sides of the hood to the base plate and Tek-screw the screen to the base plate.
4. Working down from the air inlet hood to the air heater, caulk the outside of all connections in the intake stack.

NOTE

Caulk all duct-to-duct connections and all assembly seams.

Assemble the exhaust stack

Prerequisites: The exhaust fan must already be installed.

IMPORTANT

If the roof opening is already cut, install all exhaust ductwork (including the ARV) during this step. If the roof opening is *not* cut, install the exhaust ductwork to just below the roof. (In that case, you will have to finish installing the rest of the ductwork later, after the roofer has cut the roof opening.)

NOTE

Per NFPA 33, the air inlet hood on top of the intake stack and the automatic roof ventilator (ARV) on top of the exhaust stack must be at least 10 feet away from each other.

NOTE

To connect duct sections together:

- Slip the bottom of one duct section into the top of the previous duct section.
- Ensure that the duct section is level north-south and east-west.
- Tek-screw the duct section to the previous duct section from the inside out.

Reference: Refer to the diagram below and to the RH Side Elevation view on the GA page of the Design Drawings.

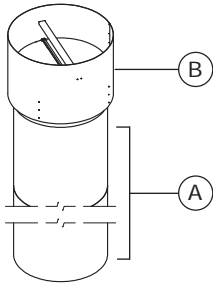

A: One or more sections of plain duct
B: Automatic Roof Ventilator (ARV)

1. Confirm that a fan ring is bolted to the top of the exhaust fan.

NOTE

If the fan ring is not present, install it now as directed in .

2. Connect a section of plain duct to the fan ring.
 - a. Place a plain duct section over the duct lip of the fan ring.
 - b. Ensure that the duct section is level north-south and east-west.
 - c. Tek-screw the duct section to the duct lip from the inside out.
3. *If applicable:* Continue connecting all the necessary plain duct sections as required for the exhaust stack.

NOTE

Follow the procedure for connecting duct sections together in the notes at the beginning of this task.

4. Install the ARV:
 - a. Slip the bottom of the ARV over the top-most duct section.
 - b. Ensure that the ARV is level north-south and east-west.

- c. Tek-screw the ARV to the duct section from the inside out.
5. Working down from the ARV to the exhaust fan, caulk the outside of all connections in the exhaust stack.

NOTE

Caulk all duct-to-duct connections and all assembly seams.

If applicable: Install the guy-wire kit

NOTE

Install the guy-wire kit per the instructions below. It is the responsibility of the customer or their agent (for example, a roofer or building contractor) to supply and install the cable tie-off points on the building roof (plate with ring). The diagram below is provided for reference only.

NOTE

Use #10 Tek screws to attach duct strap to exhaust duct; caulk to seal.

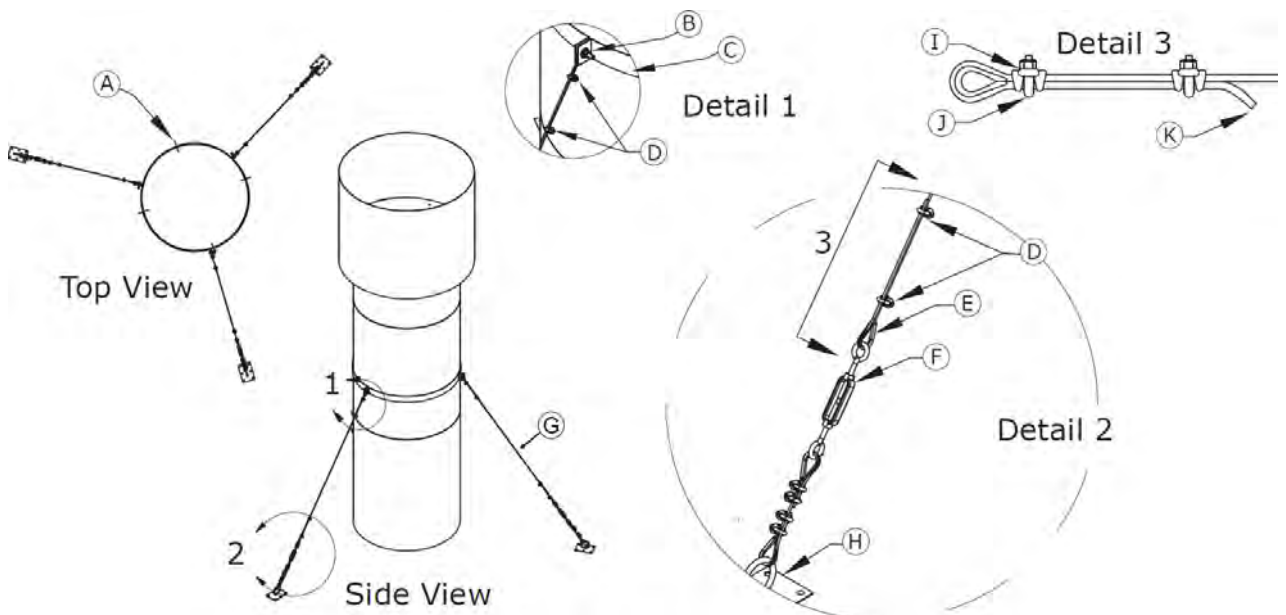

A: #10 Tek screw

B: For each connection, use one cable thimble; one 5/16-inch x 1-1/2-inch bolt; two 5/16-inch flat washers; one 5/16-inch lock washer; and one 5/16-inch nut.

C: Duct strap

D: Cable clamps (2)

E: Thimble

F: Turnbuckle

G: Cable; thimbles (2); cable clamps (4)

H: Plate with ring

I: Grip base

J: U-bolt (must have U-bolt over dead end of cable)

K: Dead end

Install the lights

Scope: This step covers *only* the mechanical installation of the lighting fixtures and running the light cables through the roof to a junction box. A qualified electrician should wire the junction box to the air heater control panel as specified in "Perform electrical hookup" (page 53).

Prerequisites: The booth must already be assembled.

References:

- Refer to the Light Fixture Installation instructions that ship with the light fixtures for instructions on installing the light fixtures into the panels.
- Refer to the Wire Harness page of the Design Drawings.
- For optional light accessories, refer to the following pages in the Design Drawings:
 - Reflector Light Fixture
 - Corner Light Harness
 - Corner Light Installation

***If applicable:* Install optional booth accessories**

Scope: This task applies only to booths that include optional accessories (for example, a parts hanger, tool cabinet, and so on).

Prerequisites: The booth lighting must already be installed as directed in “Install the lights” (page 45).

References:

- Refer to the appropriate Addendum page in the Design Drawings. (Addendum pages are numbered with an “A-” prefix.)
- Refer to the appropriate Wall Assembly page(s) in the Design Drawings for accessories that are incorporated into the wall panels, such as observation windows and rotating booth access tables.

Install the operator interface terminal

NOTE

Ensure that the placement of all electrical devices meets the NEC requirements for clearance from combustible areas.

Reference: Refer to the HMI Installation page of the Design Drawings.

Install miscellaneous electrical devices

NOTE

Ensure that the placement of all electrical devices meets the NEC requirements for clearance from combustible areas.

NOTE

This section provides instructions for installing miscellaneous electrical devices. As you install each device, retain any unused hardware. Place unused hardware in a bag and tape it to the device so that it will be available for the electrician.

Install the air-sensing tube

NOTE

The high-pressure air-sensing pressure tip must be located on the same side of the booth as the control panel, at least 84 inches from the floor and at least 24 inches from any corner.

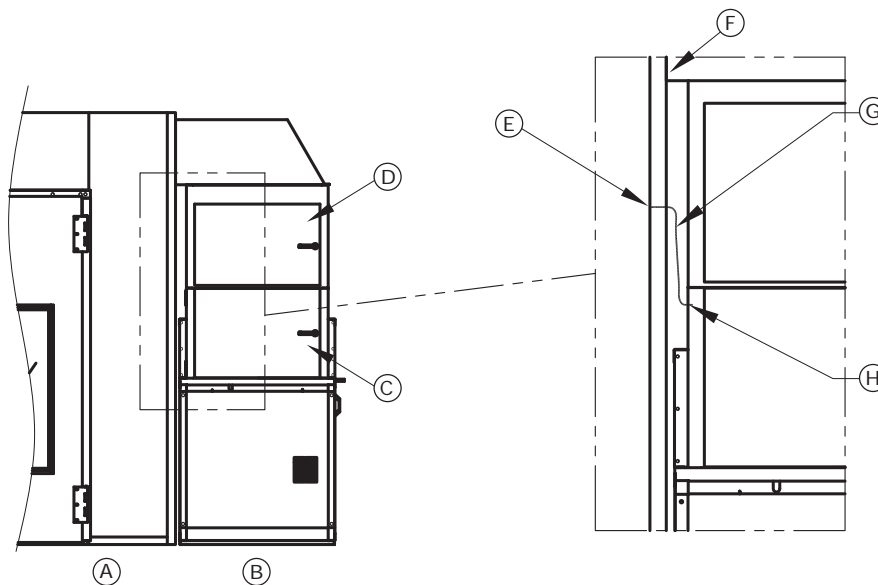

- A:** Booth (front view)
- B:** Air heater
- C:** Control panel door
- D:** Gas train access door
- E:** High-pressure air-sensing pressure tip
- F:** Booth sidewall
- G:** High-pressure air-sensing tube (AST)
- H:** Bulkhead fitting

1. Drill a 1/4-inch hole through the booth wall panel.

NOTE

The hole must be at least 84 inches from the floor and at least 24 inches from any corner.

2. Push the tubing through the wall.
3. Attach the high-pressure air-sensing tip and secure it to the inside of the booth wall.

4. Run tubing through the bulkhead fitting and attach it to the high-pressure fitting inside the control panel.
5. Attach a short tube (2-3 inches) to the low-pressure fitting inside the control panel.

Install the temperature sensor

Reference: Refer to the following sections of the Temp Sensor & Diffuser/Baffle page of the Design Drawings:

- Temp Sensor Installation
- Side Discharge BT/GUL Air Heater

***If applicable:* Install the damper actuators**

Scope: This task applies only to a booth that uses a recirc air heater. If the booth uses a forced-dry air heater, skip this task.

NOTE

This task covers the mechanical installation of the damper actuators. An electrician will perform the wiring from the actuators to the control panel, as described in “Perform electrical hookup” (page 53).

Reference: Refer to the manufacturer's documentation that shipped with the damper actuators.

Install the air solenoid valve

Prerequisites: The booth's air supply line must already be installed.

NOTE

This task covers the installation of the directional valve in the compressed air line piping, and is usually performed by a plumber or mechanical contractor. An electrician will perform the wiring from the valve to the control panel, as described in "Perform electrical hookup" (page 53).

Install the air solenoid valve as close as possible to where the compressed air enters the booth, but no closer than 3 feet to any door or opening.

NOTE

Refer to the following diagram to complete this task:

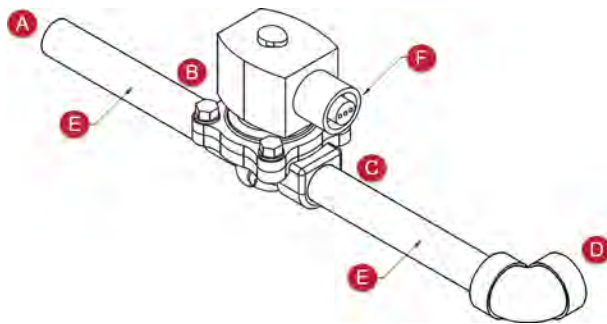

- A: From building air supply*
- B: Inlet*
- C: Outlet*
- D: Through booth wall*
- E: NPT pipe nipple (size will vary)*
- F: Conduit with wiring to control panel*

Install the Economy Mode switch

Prerequisites: The booth's air supply line must already be installed.

NOTE

The Economy Mode switch is standard on all auto refinish booths that have an air heater.

NOTE

This task covers the installation of the switch in the compressed air line piping and is usually performed by a plumber or mechanical contractor.

NOTE

Compressed air must be clean, filtered, and dry.

Connect the Economy Mode switch into the air line just before the air solenoid valve (i.e., between the air supply coming from the building and the air solenoid valve).

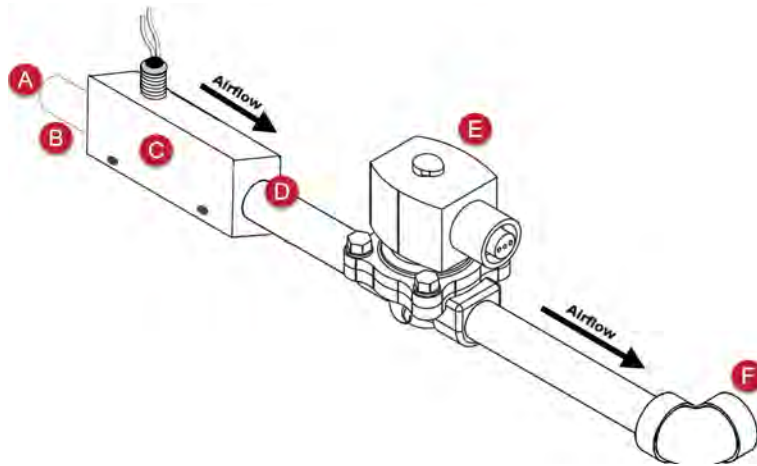

A: From building air supply

B: 1/2-inch NPT

C: Economy Switch

D: Outlet

E: Air solenoid valve

F: Through booth wall

NOTE

Install the switch horizontally, with electrical to the top.

Figure 5. Economy Switch Installation (Thomas Products Model Number 1500)

Install the air-proving switch for the exhaust stack

Reference: Refer to the instructions for Exhaust Airflow Switch Installation in the Electrical Drawings document.

NOTE

For information on locating the Electrical Drawings document, refer to “Gathering required documentation” (page 14).

***If applicable:* Install the puff switch**

Scope: This task applies only if the booth includes the GFS AdvanceCure System and the site purchased the optional puff switch with their booth.

NOTE

A puff switch is a switch located inside the booth that can be used to turn AdvanceCure on and off. It can be mounted anywhere on the inside of the booth. Mounting hardware and instructions are provided with the device.

Secure the wall panels to the floor profile

Reference: Refer to the Floor Profile Tek-Screw Detail page of the Design Drawings.

Caulk the booth

Prerequisites: The booth must already be assembled and anchored to the floor, and the booth lights must already be installed.

Reference: Refer to the Booth Caulking Guide page of the Design Drawings.

IMPORTANT

Do not caulk between fixed roof panels and explosion-relief panels. Caulking the explosion-relief panels will inhibit operation of the explosion-relief system. Refer to the Roof Panels page of the Design Drawings for details.

Prepare the air heater for startup

1. Vacuum or sweep out the intake plenum and air heater (intake and exhaust side) to remove any debris that accumulated during installation.
2. *If necessary:* Install filters in the air heater.

NOTE

This step applies in cases where you removed air heater filters in order to complete installation steps, or in cases where the air heater filters have not yet been installed.

Install booth filters

Prerequisites: Ensure that you have completed all other tasks before installing the filters. (Waiting until the end of the procedure to install the filters helps ensure that the filters remain clean.)

Install the filter racks and intake filters

NOTE

Perform this task for each filter rack.

1. Obtain a filter rack and place it on two sawhorses, with the flat side of the filter rack facing down.

2. Place the filter media on top of the filter rack, with the writing on the filter media facing down.
3. Use a filter-insertion tool (metal pizza cutter) to push the filter media into the slot all around the perimeter.

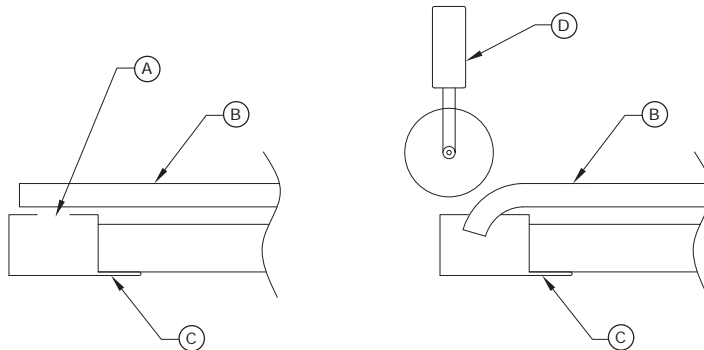

- A:** Slot in filter rack
B: Filter media
C: Filter rack
D: Filter-insertion tool (metal pizza cutter)

4. Install the filter rack in the ceiling of the booth.

Install the exhaust filters

Prerequisites: Complete all other installation tasks before installing the filters. Waiting until the end of the procedure to install the filters helps ensure that the filters remain clean.

NOTE

On a semi-downdraft booth, the exhaust filters are inserted into the filter racks of the exhaust bridge chamber.

1. Remove the filter grids from the carton.
2. Place rubber tips onto the four straight corners of the filter grids.

NOTE

The rubber tips hold the grid in place.

NOTE

Do not push the rubber tip all the way onto the grid end.

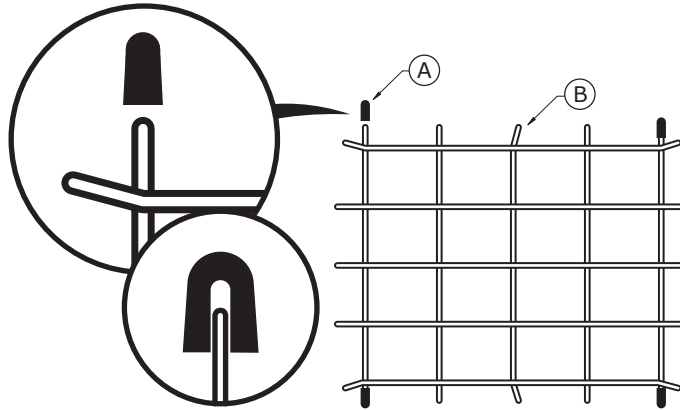

A: Rubber tip
B: Filter grid

3. Place the grids into the openings in the exhaust chamber filter racks; then install the filters onto the grids.

NOTE

Pay attention to the orientation of the filter, as shown in the accompanying diagram.

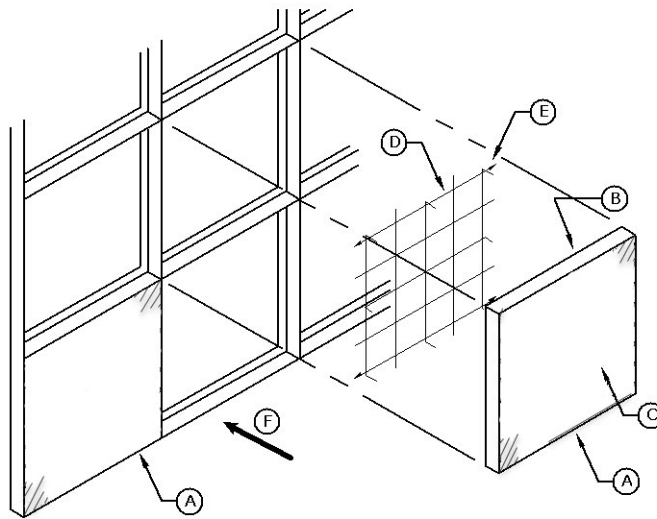

A: Exhaust filter
B: Air-leaving side (dense side of filter)
C: Air-entering side
D: Filter grid
E: Rubber tip on grid corner
F: Airflow

Perform electrical hookup

WARNING

Electrical installation should be completed by a qualified electrician. Installation must meet all applicable national, state, and local electrical codes.

Reference: Refer to the Electrical Drawings while completing this task.

NOTE

For information on locating the Electrical Drawings document, refer to “Gathering required documentation” (page 14).

1. Connect the building’s Main Power supply to the air heater control panel.

NOTE

Refer to electrical data plate for electrical requirements.

WARNING

Do not energize until you are ready to test motor rotation during commissioning and startup (see “Perform commissioning and startup” (page 54)).

2. Complete the wiring from these motors to the air heater control panel:

- Air heater intake motors
- Exhaust motors
- *If applicable:* AdvanceCure fan motors

3. Wire the lights from the junction box to the air heater control panel.

NOTE

Lights have five conductor cables:

- Black (hot) and white (neutral): Power
- Orange and red: Proximity switches
- Green: Ground

4. Wire the proximity switches on product doors and personnel doors to the air heater control panel.

NOTE

Proximity switch wire colors are:

- Brown: Hot
- Black: Signal
- Blue: Common

5. Wire these electrical devices to the air heater control panel:

- **Operator interface terminal:** Wire from terminal to control panel.
- **Temperature sensor:** Wire from probe to control panel.
- *If applicable:* **Damper actuators:** Wire from actuator to control panel.
- **Air solenoid valve:** Wire from valve to control panel.
- **Economy valve** (aka Economy Mode switch): Wire from valve to control panel.
- *If applicable:* **Puff switch** (in-booth on/off switch for AdvanceCure): Wire from switch to control panel.

Perform commissioning and startup

Prerequisites:

- The booth must be fully assembled and caulked.
- Intake filters and exhaust filters must already be installed.
- The air heater must have been vacuumed or swept out, and the air heater filters must already be installed.
- An electrician must have completed the electrical hookup.

NOTE

A trained GFS Distributor usually performs booth startup. The person who performs booth startup is responsible for completing the Final Commissioning Document and returning a signed copy to GFS.

Reference: Refer to the Final Commissioning Document. (For information on locating the Final Commissioning Document, see “Gathering required documentation” (page 14).)