

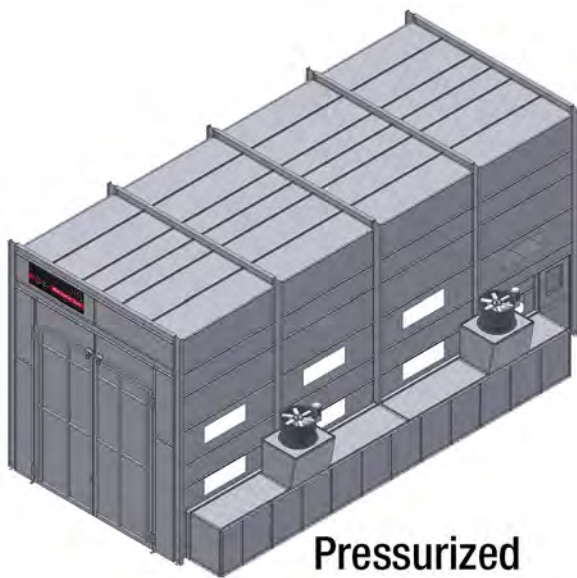

GLOBAL
FINISHING
SOLUTIONS

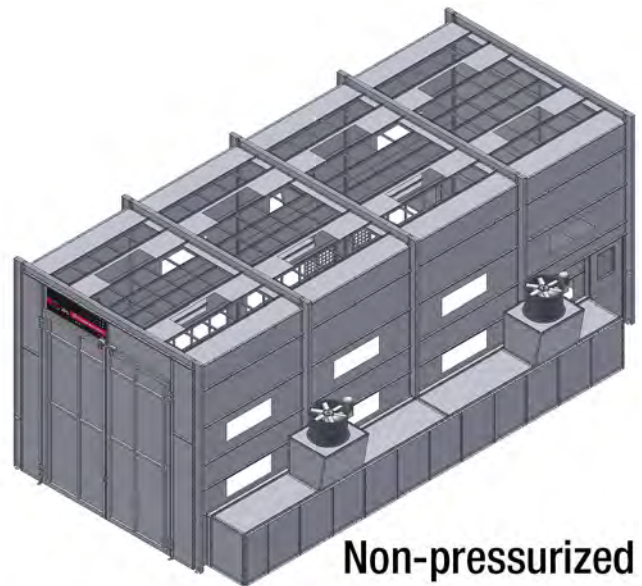

Pressurized



Non-pressurized

Large Equipment: Side Downdraft Booth

Service & Maintenance Manual

Document Number: 239-040 rev 6

Publication date 05/17/2022

Read and keep this manual for future reference. All personnel operating the equipment described in this manual should review and understand all instructions before use.

Table of Contents

Introduction	4
About Global Finishing Solutions LLC	4
Contacting Global Finishing Solutions	4
Target audience	4
Conventions used in this manual	5
Safety notices	5
Information notices	5
General safety	6
Booth safety	8
Safety features	11
Booth Overview	13
Air management	13
Air velocity	13
Booth airflow	13
Air Make-Up Unit (AMU)	14
Air pressure balance	14
Booth components	15
Doors	15
Filters	15
Manometer	15
Exhaust fan(s)	16
Lighting	16
Operator interface terminal	16
Service and maintenance	17
Maintenance schedule	17
Daily maintenance	19
Inspect and clean the manometer	19
Inspect filters and replace as needed	20
Replace the intake filters	23
Remove overspray buildup	23
Check lights	24
Weekly maintenance	24
Check operation of non-roll-up product door	24
<i>If applicable:</i> Check operation of roll-up product door	24
Monthly maintenance	26
Clean booth components	26
<i>If applicable:</i> Inspect and clean the AMU	26
Inspect and clean the exhaust fan	27
Yearly maintenance	28
<i>If applicable:</i> Inspect and clean the AMU (annual inspections)	28
<i>If applicable:</i> Check and lubricate the roll-up door	29
General service procedures	30
Replace a defective bulb	30
Replace the protective light covering	31

Adjust belt tension	32
Replace fan belts	33
Check V-belt drive alignment	33
V-belt drive considerations	35
<i>If applicable:</i> Lubricate AMU blower bearings	35
Replace fan bearings	35
<i>If applicable:</i> Reset the AMU flame safety control	36
Reset the high temperature limit switch	37
Reset the gas pressure switches	37
Common causes of excessive vibration	37
Troubleshooting	38
Spare parts and accessories	39
Consumable parts	39
Accessories	40

Introduction

About Global Finishing Solutions LLC

Leading the Industry in Paint Booth and Finishing System Technology

With decades of experience, Global Finishing Solutions is the leading manufacturer of paint booths and finishing systems for many industries, including automotive refinish, aerospace and defense, industrial manufacturing, woodworking, and large equipment. By combining high-quality components, strong relationships with paint manufacturers, and our experienced distribution network, GFS provides the best equipment and support to set your business up for success.

Contacting Global Finishing Solutions

General information

- Toll-free: 800-848-8738
- Fax: 715-597-2193
- Email: info@globalfinishing.com
- Online: www.globalfinishing.com

Technical support

- Toll-free: 800-848-8738
- Fax: 715-597-8818
- Email: techservices@globalfinishing.com

Parts and filters

- Toll-free: 800-848-8738
- Fax: 888-338-4584
- Email: parts@globalfinishing.com

Target audience

This document is intended for use by trained, experienced paint booth installers and maintenance technicians. If you have questions about the installation procedure described in this manual, contact GFS as described above.

Conventions used in this manual

This section describes how information is presented, organized, and referenced within this manual.

Safety notices

This manual uses the following standards to identify conditions related to safety hazards and equipment damage.

Table 1. Safety notices

Symbol	Description
DANGER	Indicates an imminent hazard that will result in death.
WARNING	Indicates a hazard that can result in serious personal injury or death.
CAUTION	Indicates a hazard that can result in personal injury.
NOTICE	Indicates a situation that can result in equipment or property damage, but poses no risk of personal injury.

Information notices

In addition to the safety notices described above, this manual uses a boldface keyword to identify certain other types of information.

Table 2. Information notices

Keyword	Description
NOTE	Denotes general information that provides additional context or guidance.
Important	Denotes information to which you should pay special attention.
Reference	Directs you to related content in a separate document.
Prerequisites	Specifies other tasks that must be completed or conditions that must exist before you perform the current task.
Scope	Describes limitations to the current task or conditions under which the task applies or does not apply to the procedure.

General safety

Follow all safety guidelines when assembling, operating, or servicing this product.

WARNING

There are inherent hazards associated with the operation and service of this equipment. For your personal safety, observe all safety information. Failure to observe these safety practices can result in personal injury or death.

WARNING

Operation and maintenance of this product must be performed properly by qualified personnel who observe the warnings in all documentation and notes provided with and on the product.

WARNING

Follow all general standards for installation and safety for work on installations. Follow all good practices for the proper use of lifting tackle and equipment. The use of protective equipment such as safety goggles and protective footwear must be considered.

WARNING

All persons who will operate, service, inspect, or otherwise handle this product must read and understand the safe operating practices, safety precautions, and warning messages in this documentation.

WARNING

The roofs of GFS equipment are not designed or intended to be walked upon or to support weight of any kind. As designed and manufactured, equipment roofs do not meet the minimum requirements of a safe walking and/or working surface under OSHA 1910.22. Under no circumstances should the roof be used by maintenance personnel or others for walking, standing, or storage of any kind. When necessary, roof access should be secured through the use of a properly supported platform that satisfies the minimum load requirements specified by ASCE 7 (Minimum Design Loads and Associated Criteria for Buildings and Other Structures) and ASCE 37 (Design Loads on Structures during Construction). Additionally, personnel should always utilize appropriate fall safety protocols when using an elevated platform. Use of the roof in a contrary manner may result in injury and/or death.

WARNING

Comply with OSHA guidelines and with all applicable local electrical, safety, and fire codes and standards.

WARNING

All field wiring provided must comply with local codes or, in the absence of local codes, the National Electrical Code (NFPA 70). Article 516 covers applicable of flammable and combustible materials.

WARNING

Electrical installation should be completed by a qualified electrician. Installation must meet all applicable national, state, and local electrical codes.

WARNING

Ensure that all electrical components are grounded to a central ground.

WARNING

Disconnect and lock out the main electrical service before installing, adjusting, or servicing the product.

WARNING

Guards and covers that prevent contact with electrically energized or moving parts are required and must not be removed or left open during operation.

WARNING

Welding, cutting, and other spark-producing operations shall not be permitted in or adjacent to a booth until a written permit authorizing such work has been issued. The permit shall be issued by a person in authority following his or her inspection of the area to ensure that precautions have been taken and will be followed until the job is completed.

WARNING

Local fire and building codes require fire protection. Check with local inspector authorities for requirements.

CAUTION

Read and save these instructions before attempting to assemble, install, operate, or maintain the product described. Protect yourself and others by observing all safety information. Failure to comply with instructions could result in personal injury and/or property damage. Retain these instructions for future reference.

CAUTION

This manual contains statements that relate to worker safety. Read this manual thoroughly and comply as directed. Operate this equipment in accordance with the guidelines set forth in this manual. It is impossible to list all potential hazards of this equipment. Instruct all personnel involved with this equipment in the safe conduct and operation of the system. GFS recommends that only qualified personnel operate and maintain this equipment.

CAUTION

Safety signs, panels, and labels that are normally affixed to the product must be replaced immediately if illegible or missing.

CAUTION

New or replacement parts that are installed during repair or maintenance must include all safety signs, panels, and labels as specified by the manufacturer. These must be affixed to the new or replacement parts as specified by the manufacturer.

CAUTION

Where applicable, use earplugs or take other safety measures for hearing protection.

NOTICE

The product must be installed and serviced only by a trained, qualified service technician. Incorrect installation may void the warranty.

NOTICE

If you have questions about the warranty, please contact your distributor prior to contacting GFS.

Booth safety

DANGER

Ceiling panel load capacity for installation and maintenance: You must use temporary platforms that span at least two structural frames for maintenance. **Do not walk on or apply any pressure to lights or explosion (deflagration) relief panels.**

WARNING

All equipment must be operated and maintained in accordance with local, state, and federal (OSHA) requirements governing occupational safety, fire protection, and booth operations. Operators must read and understand GFS and included independent equipment and/or component manufacturer's instructions prior to use. **Disclaimer:** GFS is not responsible for any injury, illness, or property damage that results from not abiding by local, state, or federal (OSHA) requirements that govern occupational safety, fire protection, and booth operations. GFS is also not responsible for any injury, illness, or property damage that is the result of not adhering to GFS and/or independent equipment/component operating, service, maintenance, and/or installation requirement's or directives.

WARNING

Install the booth in compliance with locally enforced codes and standards.

WARNING

A fire suppression system is required by the International Fire Code and NFPA 33. A fire suppression system is not supplied with this booth.

WARNING

Do not allow overspray to accumulate on the inside of the paint booth walls. When overspray accumulates, remove it as soon as possible to prevent a possible fire hazard. Use a non-ferrous, non-sparking scraper to eliminate any possibilities of igniting combustible material.

WARNING

Do not leave piles of paint sweepings in the booth as it creates a possible fire hazard.

WARNING

Treat used filters and any other paint-contaminated items as flammable products and dispose of them safely.

WARNING

If coatings containing nitrocellulose are sprayed in the booth, all residue must be removed from exhaust diffuser components and all exhaust filters must be changed at least once a day.

WARNING

For spray booths with an elevated temperature cure mode, any containers of ignitable (flammable or combustible) liquids shall be removed from the booth before the air heater is energized.

WARNING

Improper disposal of used filters may cause spontaneous combustion. You must consult local authorities for proper storage and disposal requirements. Guidelines include:

- Immediately remove all contaminated filters from the paint booth.
- Discard filters to a safe, detached location, place them in a non-combustible container with tight-fitting lid, or place them in a water-filled metal container to prevent a possible fire hazard.
- Disposal varies depending on the type of paint that is being captured. Consult local authorities for storage and disposal requirements.

WARNING

Duct the exhaust air from the fan away from the working environment to the outdoors. Do not operate the booth unless exhaust has been ducted properly.

WARNING

Isolate the outdoor vent from air-conditioning intakes, windows, and any other equipment that may recirculate the exhaust indoors.

WARNING

Turn on the exhaust fan before using the spray booth. Ensure that the exhaust fan is operating correctly before entering the booth.

WARNING

Check local codes to see if a booth interlock is required. A booth interlock prevents the spray devices from operating unless the exhaust fan is operating.

WARNING

Some spray activities may require the use of respiratory protection.

WARNING

Use an OSHA-approved paint spray respirator when spraying in the booth.

WARNING

Do not operate the booth when the manometer indicates the filters need to be replaced.

WARNING

Do not overfill the manometer. Overfilling allows fluid to collect in the flexible plastic connecting loop in the back of the manometer, which could cause a serious reading error. If the manometer is subject to overflow, make sure that the fluid has not passed into the plastic connecting loop.

WARNING

This equipment is designed for the removal of particulate matter only. Reduction of volatile organic compounds (VOCs) requires either coating reformulation or optional, additional equipment.

CAUTION

Become familiar with all controls before operating or servicing this booth.

CAUTION

Proper door alignment is critical to the operation of the booth. Ensure that there is equal space around the doors. Move the bottom of the door jamb to the left or right or in and out until the doors are sealed and plumb.

CAUTION

If this installation includes pumps or compressors, install and connect those devices in accordance with the manufacturer's documentation.

NOTICE

GFS recommends storing crates indoors pending installation. If you must store crates outside, protect crates and their contents from moisture to prevent damage to equipment.

NOTICE

Install the control panel per NFPA 70 and local codes and standards.

NOTICE

Failure to anchor the booth structure to the floor properly may result in structural damage.

Safety features

For operator safety, compressed air may only enter the spray gun when the booth is in Spray mode, the fans are operating, light covers are in place, airflow switches are satisfied, and the doors are closed. The following safety features are included with every booth:

- **Fire Suppression Interlock:** Two types of fire protection interlock are provided. Type 1 is typically used with a dry chemical type system that will shut down the ventilation system in the event of a fire or fault. Type 2 interlock is typically used on a wet system and will lock out the spray permissive signal to prevent any spraying, but keep the ventilation system in operation. Local Codes and AHJ must provide guidance on the interlock type.
- **Manometer:** The manometer provides a visual indication of exhaust airflow through filters and indicates when filters are dirty.
- **Lights:** All lights are inside accessible for maintenance.
- **Lighting Lens Safety Interlock:** A magnetic actuated switch mounted in the light fixture provides a safety interlock. When installed properly, the switch will prove that the lens cover is properly installed and in place. All lights are interlocked through a series circuit that will not allow for spray activity of the circuit. The light fixture remains illuminated in the fault condition.
- **Exhaust Air Proving Switch:** Exhaust air proving switch monitors differential air pressure of the exhaust fan. The switch will activate when the fan is in operation and proving the minimum amount of differential air pressure.
- **Air Solenoid Valve (ASV):** The air solenoid valve is located in the compressed air supply line to the spray equipment. All safety features listed must be functioning and not faulted before the air solenoid valve is activated.

Booths pressurized with an Air Make-Up Unit (AMU) include additional safety features:

- **Personnel Door Monitoring:** Limit switches are mounted at each of the personnel doors. All doors must be closed for paint permissive. A delay timer is included that will allow access to the booth in spray mode without interrupting spray permissive signal. If the door is not returned to a closed position, spray permissive signal is removed. Auto reset will occur when closing the door.
- **Product Door Monitoring:** Limit switches are mounted at each of the product doors. All doors must be closed for spray permissive signal. Opening of a product door will immediately remove spray permissive signal. Auto reset will occur when closing the door.
- **High Temperature Limit:** A high temperature interlock that shuts down the burner circuit if the temperature inside the booth gets too high.
- **Cure Cycle Interlock:** When the booth is placed in cure mode, spraying apparatus interlocks are de-energized. In cure mode, means are provided to deter entry into the spray booth. This is accomplished by locking out the booth lighting and monitoring the booth personnel and product door switches. Entry into the booth during cure cycle will immediately return the booth to spray mode discharge temperature, and turn on the lights. Cure mode will not be allowed to resume until an operator manually resets the fault at the operator interface terminal.

NOTICE

Cure and flash modes are available only on pressurized booths.

NOTICE

During cure mode, all booth product and personnel doors must be kept closed. If any door is opened during the process, the booth set point temperature will revert back to spray mode temperature set point. A manual reset is required at the operator interface.

Booth Overview

Air management

For the best operating environment, GFS Large Equipment Paint Booth are designed to help create and maintain optimal air velocity, airflow, and air pressure balance.

Use the information provided below to help you control and maintain your booth for optimal airflow.

Air velocity

Air velocity (the distance traveled per unit of time) is usually expressed in feet per minute (FPM). By multiplying the air velocity by the cross section area, you can determine the air volume flowing past a point in the booth per unit of time.

Booth airflow

Side downdraft booths are an economical airflow solution that do not require an exhaust pit. Air comes into the booth through a filtered ceiling plenum, and flows downward over the product. When air reaches the floor, it is pulled into floor-level, filtered exhaust plenums on both sides of the booth.

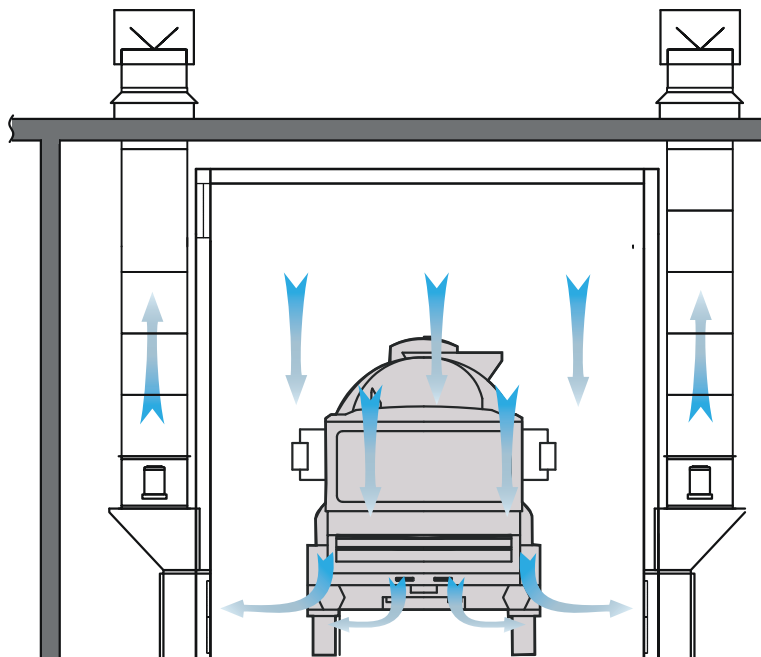

Figure 1. Airflow in a non-pressurized side downdraft booth

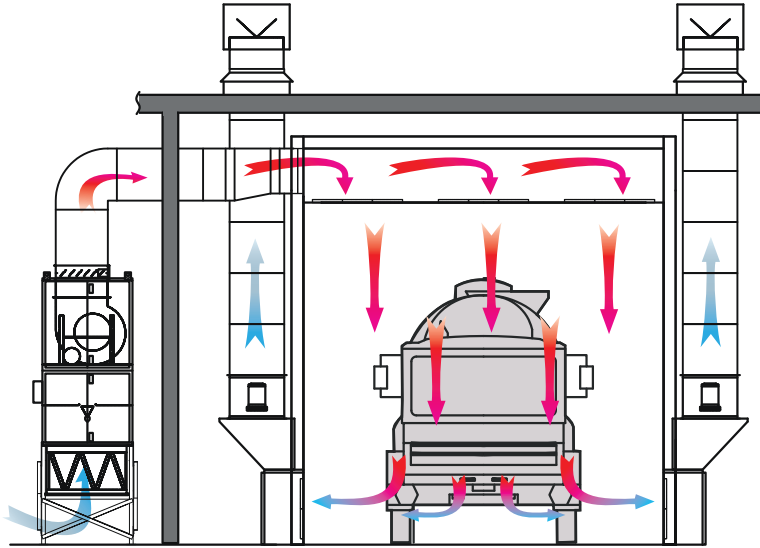

Figure 2. Airflow in a pressurized side downdraft booth. (Your booth may have a different AMU configuration than shown here.)

Air Make-Up Unit (AMU)

A pressurized booth includes an Air Make-Up Unit (AMU). The AMU supplies conditioned and filtered air to the booth, minimizing temperature variations and removing particles that compromise finish quality.

The AMU includes a heater, filters, motor and blower, and controls.

NOTE

If your booth is non-pressurized, it does not include an AMU.

Air pressure balance

Air pressure balance is the difference (in either a negative or positive value) between the inside of paint booth work zone and the area around the booth. For peak performance, air pressure should be as close as possible to neutral or zero pressure.

An enclosed booth that uses either an intake fan or an AMU is considered a *pressurized* booth. GFS pressurized booths feature an Auto Balance system that provides the following advantages:

- Helps keep contaminants out of the booth.
- Provides a streamlined airflow without turbulence.
- Supports even temperatures in the painting area.

Booth components

This section describes the main components of your booth.

Doors

A standard booth includes one personnel door and one swing-type product door (either filtered or solid, depending on airflow and pressurization).

NOTE

Depending on the options you purchased, your booth may include an alternate style of product door, such as a roll-up door or a bi-fold door.

NOTE

If you specified a drive-through configuration, your booth has *two* product doors: one at the front and one at the rear of the booth.

In pressurized booths, limit switches monitor the status of product doors and personnel doors. When a door is opened, the spray-permission signal is interrupted and the system does not allow painting to occur. Personnel doors have a built-in timer circuit that permits the door to be open for up to ten seconds without interrupting the spray-permission signal. However, opening any door immediately disables the air balancing system. When all doors are closed, the system automatically resets.

Filters

Filters are critical to the booth's operation:

- **Intake filters** help prevent dust and particulates from entering the booth.
- **Exhaust filters or exhaust filter media** capture and retain overspray, preventing paint particles from escaping into the environment.
- For a pressurized booth only: **AMU pre-filters** help prevent dust and particulates from entering the AMU.

To ensure that the booth operates properly, you must inspect and replace filters regularly. For more information, see "Inspect filters and replace as needed" (page 20).

Manometer

A manometer is mounted on the outside of your booth.

The manometer measures the pressure differential between air entering and exiting the booth. A reading that exceeds a designated amount (indicated by a red arrow on the manometer) indicates that the booth's exhaust filters need to be changed.

To ensure that the booth operates properly, you must inspect and service the manometer regularly. For more information, see "Inspect and clean the manometer" (page 19).

WARNING

Do not operate the spray booth when the manometer indicates the filters need to be replaced.

Exhaust fan(s)

The exhaust fan pulls air out of the booth and vents it to the outside.

NOTE

Depending on the size of your booth, it may have more than one exhaust fan.

CAUTION

Damage in shipping and handling or poor installation of the unit may upset the fan's balance. A fan blade that is not properly balanced can lead to excessive vibration, causing undue wear on the entire unit.

All GFS fan assemblies are statically and dynamically balanced to Balance Quality Grade G6.3. Each fan is factory run-tested for vibration in accordance with ANSI/ AMCA 204-96 "Balance Quality and Vibration Levels for Fans" to Fan Application Category BV-3, to the following peak velocity values, filter-in, at the fan test speed:

- **Rigidly Mtd.** (in/sec): 0.15
- **Flexibly Mtd.** (in/sec): 0.20

Vibration cannot be guaranteed under field conditions due to mounting and installation variables. If vibration is excessive, shut down the fan and determine the cause. See "Common causes of excessive vibration" (page 37).

Lighting

The light fixtures are designed for locations exposed to volatile flammable liquids or gases. An interlocking safety switch disables spray-gun operation if any of the light fixture covers are not properly closed.



Figure 3. Switch location

Operator interface terminal

The operator interface terminal is the screen or pushbutton controls the operator uses to control the booth. Starting the booth, painting, curing, stopping, and shutting down the booth are described in the control panel operator manual for your booth model.

Service and maintenance

Maintenance schedule

The frequency of the following maintenance checks depend upon the material being sprayed (amount and kind). The booth operators and maintenance technicians should perform these checks at regular intervals to reduce fire hazards, maintain booth efficiency, prevent freshly painted objects from becoming blemished, and hinder booth corrosion and wear. Adjust the frequency of the checks according to local guidelines and actual usage.

See “Daily maintenance” (page 19), “Weekly maintenance” (page 24), “Monthly maintenance” (page 26), “Yearly maintenance” (page 28), and “General service procedures” (page 30) for full service procedures.

Items to Be Inspected and/or Cleaned	Daily	Weekly	Monthly	Yearly
Inspect and clean the manometer	X			
Check clogged intake or exhaust filters and replace if needed.	X			
Remove overspray buildup from ceiling, walls, floor, and doors.	X			
Check lights and replace defective bulbs if needed. NOTE Replace Lens Protector or Booth Shield on light fixtures as needed.	X			
Check operation of product doors, including non-roll-up and roll-up doors, if applicable.		X		
Clean intake duct, exhaust duct, intake plenum, exhaust plenum, and control panel housing, as necessary.			X	
<i>If applicable:</i> Inspect and clean the Air Make-Up Unit (AMU).			X	
Inspect and clean the exhaust fan, including the fan inlet and intake areas.			X	

Service and maintenance

Items to Be Inspected and/or Cleaned	Daily	Weekly	Monthly	Yearly
<p><i>If applicable:</i> Inspect and clean the AMU (annual inspection)</p> <ol style="list-style-type: none"> 1. Inspect and replace any torn or worn belts. 2. Inspect bolts and screws and tighten as necessary. 3. Remove dust and grease from the motor housing/wheel housing. <p>NOTE Clean exterior surfaces only.</p> <ol style="list-style-type: none"> 4. Check for gas leaks and seal leaks if present. 5. Rub the flame sensor with steel wool to remove any rust buildup. 6. Clean the burner with a wire brush and make sure burner ports are free of debris. 				X
<p><i>If applicable:</i> Check and lubricate the roll-up door.</p>				X

Daily maintenance

This section contains tasks that should be performed every day.

Inspect and clean the manometer

Perform the following steps to inspect and clean the manometer.

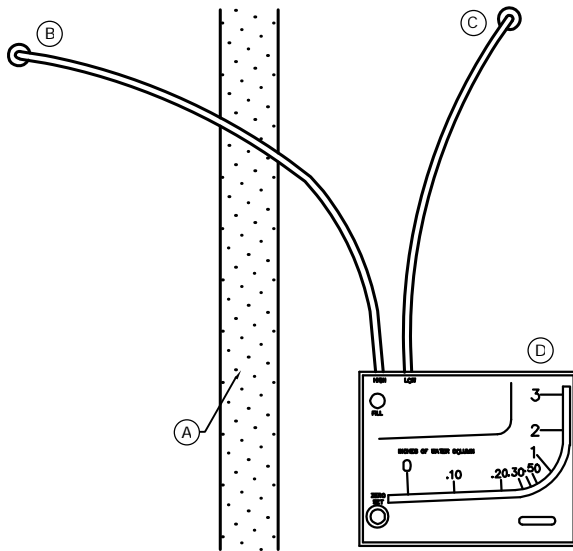

- A: Filter media
- B: High-pressure line to booth side of filters
- C: Low-pressure line to chamber side of filters
- D: Manometer

1. With the booth operating, check the manometer to determine if the filters need to be replaced.

NOTE

Filters must be replaced when the fluid gauge passes the red dirty filter arrow.

NOTE

For GFS Wave and GFS Poly filters, the red dirty filter arrow should be placed at 1/2-inch w.c. For other types of filters, the arrow should be placed per the manufacturer's recommendations.

WARNING

Do not operate the spray booth when the manometer indicates the filters need to be replaced.

2. Check the fluid level in the manometer and adjust as needed.

WARNING

Do not overfill the manometer. Overfilling allows fluid to collect in the flexible plastic connecting loop in the back of the manometer, which could cause a serious reading error. If the manometer is subject to overflow, make sure that the fluid has not passed into the plastic connecting loop.

3. Make sure the manometer reads zero when the booth is off. If not, zero the manometer with the white adjustment knob.

NOTE

Make sure the tubing is disconnected and the gauge is open to the atmosphere before adjusting zero.

4. Clean the manometer with mild soap and a soft, damp cloth.

Inspect filters and replace as needed

FOLLOW GFS' RECOMMENDED REPLACEMENT PROGRAM FOR FILTERS. Use GFS replacement filters for the AMU, intake, exhaust, and other components as needed. GFS filters are designed to provide high-efficiency particulate removal and will maintain balanced airflow during the life of the filter.

All booths use two types of filters: intake and exhaust. Pressurized booths also use pre-filters (also known as “filter sections”) in the AMU.

The buildup of paint overspray on the exhaust filters must be monitored to ensure the filters are capturing overspray and do not become overloaded. Monitoring may be accomplished with a manometer, or via an effective inspection program. A manometer is a standard booth accessory (GFS part number 1011003).

Table 3. Filter replacement schedule

Filter type	Visual inspection frequency	Filter-replacement frequency ¹²	
		Pressurized booth	Non-pressurized booth
AMU pre-filter (“filter section”)	At least every two weeks	At least every two months	n/a
Intake filters	Daily	At least every four to six months	At least every two months
Exhaust filters	Daily	When indicated by manometer	When indicated by manometer

¹Change filters immediately if they become saturated sooner than the recommended replacement interval.

²If coatings sprayed in the booth contain nitrocellulose, change filters at least daily.

NOTE

Some weather conditions (e.g., smog, fog, frost, etc.) produce atmospheric dust concentrations that may be much higher than normal. In such conditions, intake filters and AMU pre-filters may become saturated in a short time.

All filters should fit tightly in filter frames. If filters do not make a proper seal with the filter frames, unfiltered air will pass to the next part of the system. Take extreme care to make sure intake filters are installed properly. Improperly installed intake filters will allow unfiltered air into the booth's work area. This unfiltered air may deposit visible dirt particles on the work surface and item being painted.

Keep a set of replacement filters on hand. For information on ordering filters, see “Consumable parts” (page 39).

To ensure that maintenance procedures are followed correctly, have your local authorized and factory-trained GFS distributor maintain your system.

WARNING

Treat used filters and any other paint-contaminated items as flammable products and dispose of them safely.

WARNING

If coatings containing nitrocellulose are sprayed in the booth, all residue must be removed from exhaust diffuser components and all exhaust filters must be changed at least once a day.

WARNING

Improper disposal of used filters may cause spontaneous combustion. You must consult local authorities for proper storage and disposal requirements. Guidelines include:

- Immediately remove all contaminated filters from the paint booth.
- Discard filters to a safe, detached location, place them in a non-combustible container with tight-fitting lid, or place them in a water-filled metal container to prevent a possible fire hazard.
- Disposal varies depending on the type of paint that is being captured. Consult local authorities for storage and disposal requirements.

Replace the exhaust filters

NOTE

Perform this task at recommended intervals (see “Inspect filters and replace as needed” (page 20)) and any time the manometer indicates that the exhaust filter needs to be replaced.

NOTE

Verify that the correct replacement filters are available before removing used filter media. Before servicing, remove and lockout/tagout the main electrical source.

NOTE

The exhaust filters are inserted into the filter racks along the lower side walls of each bay.

1. Remove and safely dispose of used filter media.

WARNING

Treat used filters and any other paint-contaminated items as flammable products and dispose of them safely.

2. Remove the new filter grids from the carton.
3. Place rubber tips onto the four straight corners of the filter grids.

NOTE

The rubber tips hold the grid in place.

NOTE

Do not push the rubber tip all the way onto the grid end.

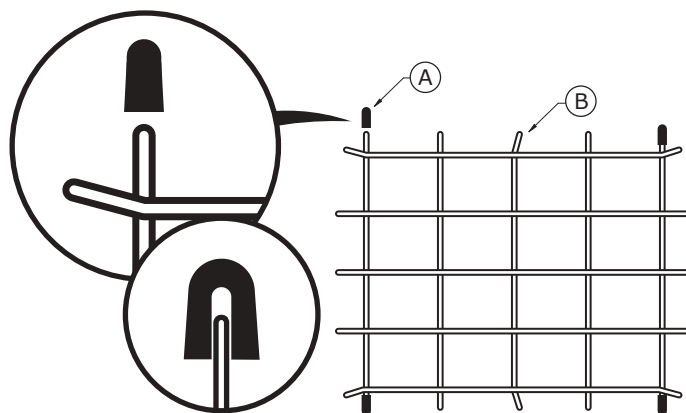

A: Rubber tip (do not push the tip all the way onto the grid end)
B: Filter grid

4. Place the grids into the openings in the exhaust chamber filter racks; then install the filters onto the grids.

NOTE

Pay attention to the orientation of the filter, as shown in the accompanying diagram.

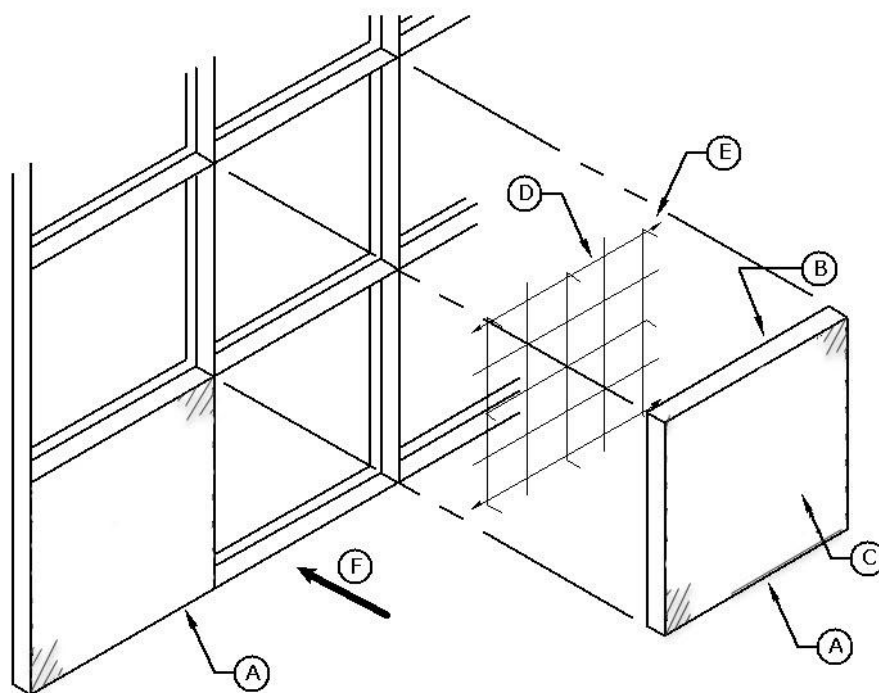

A: Exhaust filter
B: Air-leaving side (dense side of filter)
C: Air-entering side
D: Filter grid
E: Rubber tip on grid corner
F: Airflow

Replace the intake filters

NOTE

Perform this task at recommended intervals (see “Inspect filters and replace as needed” (page 20)) and any time visual inspection or booth performance indicates that the filter needs to be replaced.

NOTE

Verify that the correct replacement filters are available before removing used filter media. Before servicing, remove and lockout/tagout the main electrical source.

NOTE

The intake filters are inserted into the filter racks in the ceiling of each bay

1. Remove and safely dispose of used filter media.

WARNING

Treat used filters and any other paint-contaminated items as flammable products and dispose of them safely.

2. Insert the new intake filter into the filter rack so that the tacky side of the filter is toward the air-leaving side of the booth.

NOTE

Ensure that the filter is under the bolt or bolt head, as shown in the inset, below.

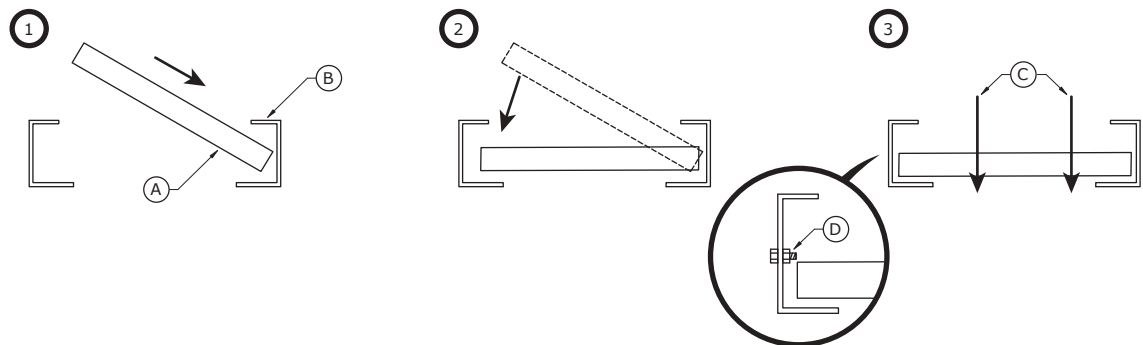

A: Tacky side of intake filter

B: Filter rack

C: Airflow direction

D: Keep the filter under the bolt or bolt head

Remove overspray buildup

WARNING

Do not allow overspray to accumulate on the inside of the paint booth walls. When overspray accumulates, remove it as soon as possible to prevent a possible fire hazard. Use a non-ferrous, non-sparking scraper to eliminate any possibilities of igniting combustible material.

1. Remove overspray buildup from the following locations:
 - Ceiling
 - Walls

- Floor

NOTE

If you use protective booth paper or coating, replace it when it becomes worn or dirty.

- Doors

NOTE

Check to make sure the door opens and latches without difficulty.

2. Visually inspect all other surfaces for accumulated buildup; remove overspray or clean as required.

Check lights

Inspect the lights to look for individual lights that are dim or burned out, and to evaluate overall light quality:

- **If a specific light bulb is burned out or is noticeably dimmer than the other bulbs:** Follow the instructions in “Replace a defective bulb” (page 30) to replace the affected bulb.
- **If the overall light quality is diminished:** Follow the instructions in “Replace the protective light covering” (page 31) to replace the protective layer or clean the light.

Weekly maintenance

This section contains tasks that should be performed every week. Increase or decrease frequency as needed for specific operating conditions and use of the booth.

Check operation of non-roll-up product door

Perform the following steps to check the functionality of each non-roll-up product door installed in the booth.

1. Remove any overspray from the door or clean as required.
2. Check that the door swings freely.
3. Check that the latch holds the door in place.
4. Check that the closed door has a good seal.

***If applicable:* Check operation of roll-up product door**

Perform the following steps to check the functionality of the roll-up door safety edge.

1. Open or close the door to set it at the 6-foot open position (approximate).



2. Press and hold the **Close** button. When the door is in motion, press up on the door seal as shown.

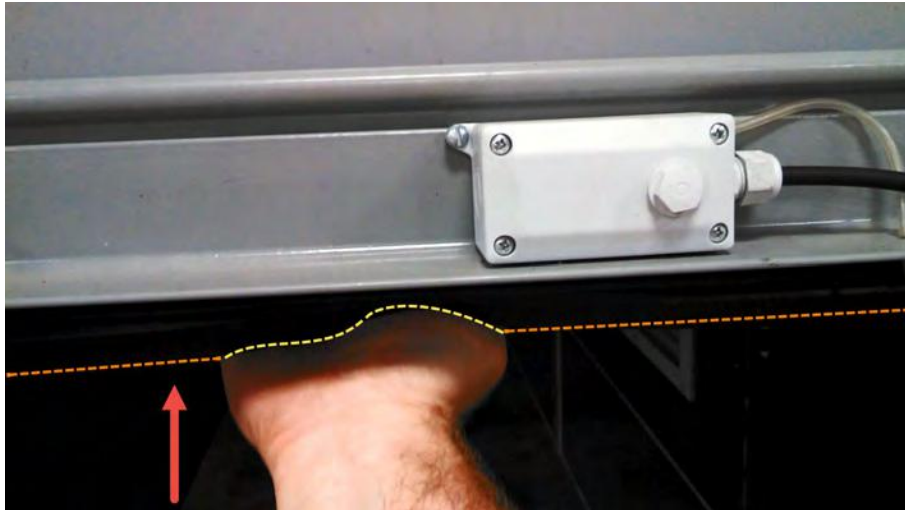

If door safety edge is functioning correctly, the door should stop closing and then return to the full-open position.

Monthly maintenance

This section contains tasks that should be performed on a monthly basis. Increase or decrease frequency as needed for specific operating conditions and use of booth.

Clean booth components

WARNING

Do not attempt maintenance on the air make-up unit (AMU) until the electrical supply has been completely disconnected and the main gas supply valve has been turned off. Before servicing, disconnect and lock out the AMU. This includes the main electrical service and the main gas supply.

1. Inspect the intake and exhaust ductwork. If needed, scrape off any build-up; then sweep or vacuum it up. Dispose of build-up or other waste safely.

WARNING

Paint-contaminated items are flammable and may cause spontaneous combustion. Consult local authorities for proper storage and disposal requirements.

2. Inspect intake and exhaust plenums as necessary. If needed, scrape off any build-up; then sweep or vacuum it up. Dispose of build-up or other waste safely.
3. Inspect the control panel housing. If needed, clean with a compressed air duster or vacuum.

If applicable: Inspect and clean the AMU

WARNING

Do not attempt maintenance on the AMU until the electrical supply has been completely disconnected and the main gas supply valve has been turned off. Before servicing, disconnect and lock out the AMU. This includes the main electrical service and the main gas supply.

CAUTION

Use care when touching the exterior of an operating motor or a motor that has just been shutdown. Motors usually run hot and may be hot enough to be painful or cause injury.

1. Check that the fan inlet and intake area (approaches to the ventilator) are free from obstructions and clean.
2. Use caution around hot components (see Caution above). Although motors are usually permanently lubricated, check the bearings for excessive play (replace if necessary). If grease fittings are present, lubricate periodically (see "*If applicable: Lubricate AMU blower bearings*" (page 35)).
3. Check the fan, wheel, other moving parts, and the inlet, especially if the blower is installed in a corrosive or dirty environment.

Occasionally, oil, dust, or overspray may accumulate on the fan causing an imbalance. For smooth and safe operation, inspect and clean the wheel and other moving parts as needed.

4. Check AMU belt tension (see "Adjust belt tension" (page 32)).
5. Check AMU V-belt alignment (see "Check V-belt drive alignment" (page 33)).
6. After performing the above maintenance checks, check that all fasteners are tight.
7. When the booth has been returned to a safe for operation state, remove locks and restore power.

Inspect and clean the exhaust fan

CAUTION

Use care when touching the exterior of an operating motor or a motor that has just been shut down. Motors usually run hot and may be hot enough to cause pain or injury if touched.

1. Before servicing, disconnect and lock out the exhaust fan, including the main electrical service.
2. Check that the fan inlet and the intake area (i.e., the approaches to the exhaust fan) are clean and free from obstructions.
3. Check the bearings for excessive play and replace, if necessary.

NOTE

In most cases, the motors are permanently lubricated.

4. Clean any accumulated oil and dust from the fan, inlet, wheel, and other moving parts.

NOTE

Accumulated oil and dust can cause an imbalance in the fan's rotation. If the blower is installed in a corrosive or dirty location, you may need to inspect and clean the wheel and other moving parts more often than monthly.

5. Check the fan belt tension; adjust the tension, if necessary.
6. Inspect the V-belt alignment; adjust the alignment, if necessary (see "Check V-belt drive alignment" (page 33)).
7. After performing the above maintenance checks, check that all fasteners are tight.
8. When the booth has been returned to a state that is safe for operation, remove locks and restore power.

Yearly maintenance

This section contains tasks that should be performed on a yearly basis. Increase or decrease frequency as needed for specific operating conditions and use of booth.

NOTE

Once each year, perform these tasks in addition to the monthly maintenance tasks.

If applicable: Inspect and clean the AMU (annual inspections)

WARNING

Do not attempt maintenance on the AMU until the electrical supply has been completely disconnected and the main gas supply valve has been turned off. Before servicing, disconnect and lock out the AMU. This includes the main electrical service and the main gas supply.

CAUTION

Use care when touching the exterior of an operating motor or a motor that has just been shut down. Motors usually run hot and may be hot enough to cause pain or injury if touched.

1. Before servicing, disconnect and lock out the AMU, including the main electrical service and the main gas supply.
2. Inspect the AMU fan belt for wear; replace any torn or worn belts (see “Replace fan belts” (page 33)).
3. Inspect bolts and set screws for tightness. Tighten as necessary.
4. Inspect motor for cleanliness. Clean exterior surfaces only. Remove dust and grease from the motor housing to ensure proper motor cooling. Remove dirt and grease from the wheel and housing to prevent imbalance and damage.
5. Check for gas leaks; seal any leaks, if present.
6. Rub the flame sensor with steel wool to remove any rust buildup.
7. Clean the burner with a wire brush and make sure burner ports are free of debris; then wipe the burner with a clean rag.

NOTE

If needed, use a drill bit to clean the ports:

- **Gas port:** Drill size 31 (0.120 inch; 3.048 mm)
 - **Air port:** Drill size 43 (0.089 inch; 2.261 mm)
8. When the booth has been returned to a safe for operation state, remove locks and restore power.

If applicable: Check and lubricate the roll-up door

Perform all preventive maintenance recommended by the door manufacturer (refer to the door manufacturer's documentation).

Also pay particular attention to the following inspection points:

1. Inspect all door fasteners to confirm that they are properly tightened. Tighten all loose fasteners according to the values in the table, below.

Table 4. Torque Recommendations for Guide Assembly and Wall Fasteners

Bolt Size/Type	Torque (ft-lbs)¹
1/4-20 Grade 2 steel bolt	6
5/16-18 Black Oxide Socket Cap	25
3-16 18-8 stainless steel bolt	20
3/8-16 Grade 2 steel bolt	20
3/8-16 Grade 5 steel bolt	31
1/2-13 Grade 5 steel bolt	75
1/2-13 Grade 8 steel bolt	107
5/8-11 Grade 8 steel bolt	212
3/4-10 Grade 8 steel bolt	376

¹The recommended torque for steel bolts is based on a plated bolt that has not been lubricated.

2. Inspect bearings for binding or excessive noise. If a grease fitting is present, apply grease. Contact GFS technical services for assistance if needed.
3. Inspect chain for damage and for proper lubrication. Apply chain lube as needed. Contact GFS technical services for assistance if needed.
4. Inspect the door's guide weather seal for damage and missing areas. Replace seal if needed.
5. Refer to the door manufacturer's documentation (maintenance schedule and operator's troubleshooting information) if there are any other door maintenance issues.

General service procedures

This section contains procedures that can be performed as needed to correct problems or as directed by the preventive maintenance schedules in “Daily maintenance” (page 19), “Weekly maintenance” (page 24), “Monthly maintenance” (page 26), and “Yearly maintenance” (page 28).

Replace a defective bulb

NOTE

Perform this task if a specific light bulb is burned out or is noticeably dimmer than the other bulbs.

WARNING

Before servicing, lockout/tagout the main electrical service to the booth.

1. Remove and lockout/tagout power supplied to the booth.
2. Remove any protective covering from the light whose bulb is being replaced:
 - **If you use Lens Protector:** Remove the Lens Protector plastic sheet.
 - **If you use Booth Shield:** Score around the light and peel off the Booth Shield covering.
3. Removing the eight (6 mm x 20 mm) cap-head screws that secure the light cover to the panel.

NOTE

Make sure to support the light cover when removing the last screws.

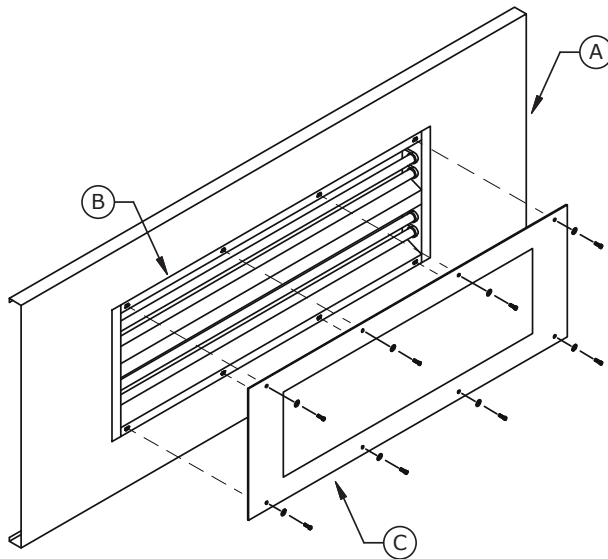

A: Light panel

B: Light fixture installed in light panel

C: Light cover

4. Pull the light cover away from the panel and place the cover in a safe place.

NOTE

If you do not use a protective covering on the lights, you might have to clean overspray from the light cover and panel before you can remove the light cover.

5. Remove the burned-out light bulb.

NOTE

A heavy-duty, pressure lock telescopic lamp holder holds the tube in place.

6. Replace the bulb by pushing one end of the new tube into one of the two spring-loaded holders, and then sliding the other end into the other holder.
7. Replace light cover and secure it with the eight (6 mm x 20 mm) cap-head screws.
8. Once all light covers have been installed and the booth is safe to operate, remove the lockout/tag-out and apply power to the booth.
9. Verify that all light bulbs illuminate.
10. *If applicable:* Apply a fresh protective covering over the light:
 - **If you use Lens Protector:** Apply a new plastic sheet.
 - **If you use Booth Shield:** Reapply Booth Shield and wait for it to dry.

Replace the protective light covering

Scope:

- If brightness is diminished but you do *not* use a protective covering on the lights, use a non-ferrous, non-sparking scraper to remove overspray buildup from the lights.
- Perform the task below if the brightness of the lights seems diminished overall *and* if you use a protective covering on the booth lights.

NOTE

GFS recommends that you use Light Fixture Lens Protector or GFS Booth Shield to protect your booth lights from overspray. Lens Protector is a plastic peel-off film; Booth Shield is a peelable coating. Both products are available from your local distributor or from the GFS Parts Department. For more information, see “Accessories” (page 40).

1. Remove the protective covering from all lights:
 - **If you use Lens Protector:** Remove the Lens Protector plastic sheet.
 - **If you use Booth Shield:** Score around the edges and peel the clear Booth Shield covering off the surfaces.
2. Discard the used covering.
3. Apply a fresh layer of protective covering over all the lights:
 - **If you use Lens Protector:** Apply a new plastic sheet.
 - **If you use Booth Shield:** Reapply the clear Booth Shield and wait for it to dry.

Adjust belt tension

Belt tension is very important to the proper operation of a fan and to the service life of a V-belt drive. The belts on a new fan are properly adjusted; however, all V-belts stretch in the first few hours of operation. It is necessary to readjust the belt tension after eight hours of running. After approximately 100 hours of running, the belts should be adjusted again. Thereafter, tracking the number of hours the booth is in use and periodic inspection are recommended so belts may be adjusted or replaced when necessary.

WARNING

Operating drives without guards in place can result in severe injury or death. If you remove any guards, make sure you replace them before removing locks and restoring power.

WARNING

Before servicing, lockout/tagout the main electrical service to the device.

CAUTION

Do not tighten belts by changing the setting of the motor pulley as this changes the fan speed and may damage the motor.

NOTICE

Over-tightening results in too much tension, causing excessive belt wear and noise. Under-tightening results in too little tension, causing slippage at start-up and uneven wear.

- **To service an AMU fan:** Disconnect and lock out the main electrical service to the AMU.
- **To service an exhaust fan:** Disconnect and lock out the main electrical service to the exhaust fan.

1. Measure the belt span as illustrated below.

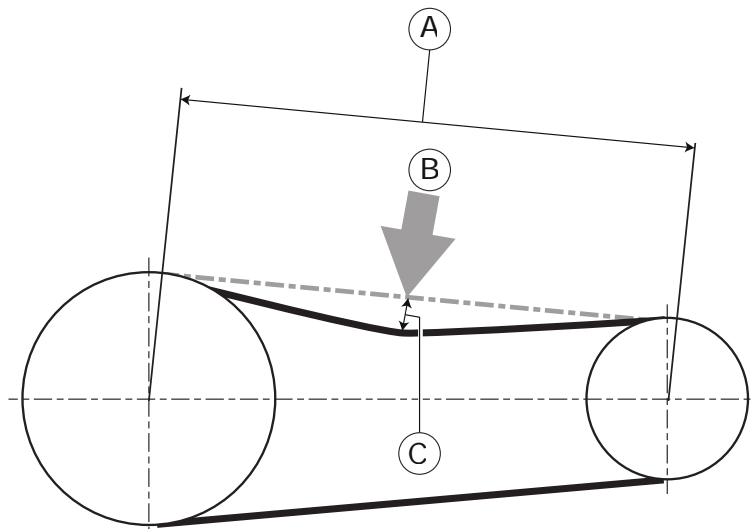

A: Span length
B: Force
C: Deflection

2. Calculate the required deflection by multiplying the belt span by 1/64.

For example, if the belt span is 32 inches, the belt deflection equals 1/2 inch (32 inches x 1/64 = 1/2 inch).

3. Apply the force from the following table evenly across the width of the belt at the center of the belt span and measure the deflection.

NOTE

A strip of keystock or similar material may be used to distribute the force evenly across the belt width.

Table 5. Belt deflection force

Belt type	New belt force (measured in pounds)	Used belt force (measured in pounds)
A	4.2-8.0	2.8-5.4
B	6.7-9.4	4.5-6.3
5VX	18.9-23.4	11.2-15.5

4. With the force still applied, measure the actual belt deflection. Adjust the belt tension if the measured belt deflection is greater than the calculated deflection.
5. When the booth has been returned to a safe for operation state, remove locks and restore power.

Replace fan belts

WARNING

Before servicing, lockout/tagout the fan, including the main electrical service.

1. Loosen the motor hold-down bolts and move the motor toward the fan. (This is done by turning a jackscrew which is a part of the motor base on models having larger motors.) The belt may be slipped off the motor sheave and then easily removed from the sheave on the blade shaft.
2. Check the numbers on the belt and make the replacement with a belt having the same length and section.



3. Adjust the motor outward to tighten the belt (see “Adjust belt tension” (page 32)) and tighten the motor hold-down bolts. Be sure that the motor is not cocked at an angle and that the end face of the motor sheave is parallel to the end face of the driven sheave.
4. Adjust the belt tension (see “Adjust belt tension” (page 32)).
5. After performing the above maintenance, check that all fasteners are tight.
6. When the booth has been returned to a safe for operation state, remove locks and restore power.

Check V-belt drive alignment

Proper alignment and balance of the V-belt is important; check the following items to ensure smooth fan operation.

1. Check that the fan and motor sheaves are in axial alignment; adjust sheaves as required.

NOTE

Shafts are parallel in both the vertical and horizontal planes.

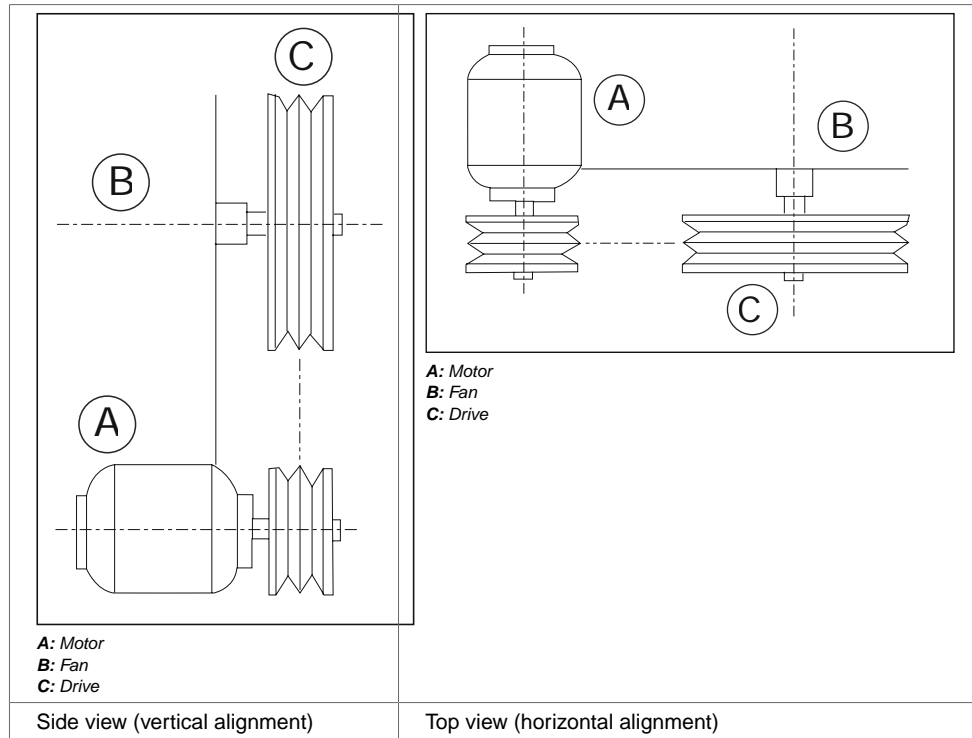

2. Check that the fan motor sheaves are in radial alignment; adjust sheaves as required:
 - When sheaves are of equal width, align the sheaves with a straight-edge (inset A).
 - When sheaves are of unequal width, align the center of the sheaves (inset B).

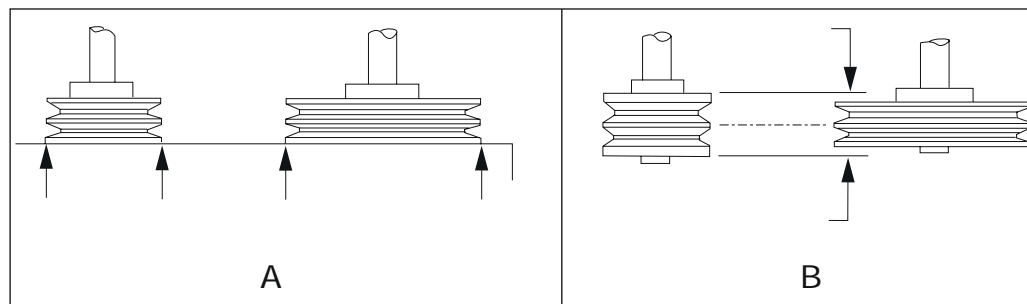

A: Equal-width sheaves: Align to straight-edge touching sheaves at arrows
B: Unequal-width sheaves: Align to center of sheaves

3. Verify that sheaves have no noticeable eccentricity.
4. If adjustments were made, check belts for proper tension.

NOTE

Belts that are either too loose or too tight cause vibration and excessive wear. (see “Adjust belt tension” (page 32), as applicable).

5. After all adjustments have been completed, check the complete assembly for smoothness of operation.

V-belt drive considerations

V-belt drives on GFS fans are purposely sized to handle considerably more load than would be necessary for normal drive design. This is done to prolong the life of the drive and provide for minimum maintenance. Belts should be replaced when they have obviously become worn, even though they are still operating. A badly worn belt will also cause undue sheave wear.

Replace belts when they show definite signs of wear; otherwise the sheaves will become worn to the point where they also must be replaced. Never put new belts on a badly worn sheave. This will reduce the capacity of the drive and cause excessive belt wear.

Most GFS fans are provided with an adjusting screw as a part of the motor base for easy setting of belt tension. However, small fans or fans using small horsepower motors may have only a slotted base plate.

When the belt tension is adjusted by moving a motor on a slotted base, be sure to block the motor tightly and squarely before tightening the hold-down bolts, keeping the motor sheave in line with the belt. The motor sheave must be parallel to and in line with the fan sheave.

When you replace belts on a multi-groove drive, be sure they are used in a matched set. If you are not sure whether the belts are matched, observe them in operation. The tight side should be perfectly straight and the belts should run smoothly and in line. The slack side should bow out and also be in line.

If one of the belts extends out considerably farther than another, it is an indication that the belts are not matched and should be changed. If there is only a slight difference, the normal stretching in the first hours of operation will equalize the belt lengths and the belts will be well matched.

***If applicable:* Lubricate AMU blower bearings**

Although blower bearings require little lubrication, use a lithium-based grease when required.

1. Before servicing, disconnect and lock out the main electrical service to the AMU.

CAUTION

Do not grease bearings from inside the enclosure with the motor energized.

2. Lubricate each fitting. If touching the bearings, make sure the bearings are cool. Rotate them as they are lubricated (evenly distributes the grease).
 - **For 1/2-inch to 1-7/16-inch shaft diameters:** Use one-half pump of grease
 - **For 1-11/16-inch shaft diameters and larger:** Use one-full pump of grease
3. When the booth has been returned to a safe for operation state, remove locks and restore power.

Replace fan bearings

Follow the assembly and alignment procedure when installing replacement bearings. Inspect the shaft for wear at the bearing mounting positions. Shaft diameter should not be undersized more than commercial ground and polished tolerances. Excessive undersizing will result in rapid wear.

1. Place new bearings loosely on the shaft.

NOTE

Locking collars may be located on either end of the bearings for ease of installation. The illustration shows one locking collar on the drive end and one locking collar on the fan end, which is typical for a tubeaxial type fan. A typical SWSI centrifugal fan would have both collars mounted on the sheave side of the bearings. Drop the mounting bolts in place, snug them, and adjust the position of the shaft with proper spacing at either end.

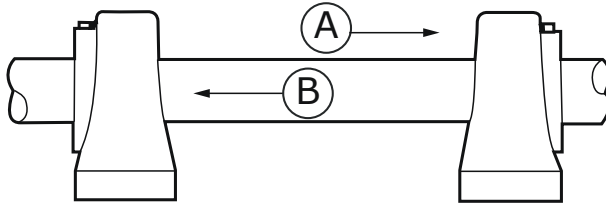

A: Airflow
B: Thrust

- Using the blade as a guide, center both ends of the shaft in the housing of tubeaxial fans.

NOTE

On centrifugal fans, the shaft is positioned 90° to the scroll side, with the wheel inlet centered in the scroll inlet. Use the clearance in the mounting holes for horizontal adjustment. Use shims for vertical adjustment, if necessary.

- Confirm that the shaft and bearings are in proper alignment.

NOTE

The shaft should slide freely from end to end.

- Tighten the bearings to the base plate; then check the position of the shaft again.
- Tighten the eccentric cam locking collar of the bearing at the blade/wheel end. (The locking collar design provides a positive lock of the wide inner ring bearing to the shaft. To tighten, turn the locking collar in the direction of shaft rotation to the lock position, then tighten the collar set screw.) Repeat this procedure for the sheave end locking collar on DWDI and open wheel centrifugal models. For other fan types, proceed to the next step.
- Axial flow blade and single inlet centrifugal wheels with back plates exert an air thrust toward the fan inlet. To help balance the bearing loading, we allow the fan end bearing (belt driven units) to carry the majority of this thrust loading while the sheave end bearing carries most of the radial load. (Direct coupled units would be just the opposite.) To accomplish this, grasp the sheave end of the shaft and pull or push on it toward the fan inlet. At the same time, tap the locking collar of the sheave end bearing (fan end on direct coupled units) in the opposite direction with a soft mallet.
- The final step is to tighten the sheave end bearing eccentric cam locking collar while maintaining constant pressure on the shaft toward the fan inlet.

NOTE

For special heavy duty bearings, a spring locking collar is used. The two knurled cup-point set screws extend through the inner ring of the bearing and lock firmly onto the shaft. Tighten the blade end collar first, then take hold of the sheave end of the shaft, pull and then tighten the locking collar. The locking collar is tightened by using the two set screws mentioned above.

If applicable: Reset the AMU flame safety control

If the flame safety control alarm light is on (locked out), manually reset the unit.

NOTE

Canadian Units have a flame safety control that contains a reset button. To reset a Canadian Unit, press the reset button (the unit needs to be powered on to be reset).

1. Turn off power to the unit.
2. Turn power to the unit back on.

Reset the high temperature limit switch

Typically, two high temperature limit switches protect the system in the event a failure causing high temperature in the AMU blower cabinet or high blower discharge temperature. One device automatically resets when temperature falls under the device's setpoint. The second device requires manual reset after a high temperature fault. The booth uses one of the following types of manual reset, high temperature limit switches:

- **Honeywell:** Press the red button toward the bottom (on the face) of the limit device
- **Johnson Penn:** Press the metal push tab (flag) on the top of the switch

NOTE

Either type can be reset with or without power applied to the booth.

NOTE

You may not feel any change in the device as you reset it.

Reset the gas pressure switches

Units are equipped with manual reset high and low gas pressure switches. The burner will not operate if a switch is tripped. To reset a switch, follow the reset instructions provided on the top of the switch.

Common causes of excessive vibration

- Damage in shipping and handling or poor installation may upset the unit's balance
- The support structure is not sufficiently rigid or level. Resonance in the ductwork or support structure amplifies vibration.
- Belt tension is too tight or too loose.
- The bearing locking collar or mounting bolts are loose.
- The blade set screw is loose.
- Material has accumulated on the blade.

Troubleshooting

Use this decision table to troubleshoot booth operation.

Table 6. Operator Troubleshooting Decision Table

Symptom	Probable Cause	Remedy
Not enough airflow in the booth	Dirty filter	Change the filters.
	Obstructed filters	Remove any obstructions.
	Incorrect filter	Change the filter to match the specifications.
	The fan is not turning	Non-pressurized booth: Make sure the control panel has power. If you depress the exhaust button and the fan does not come on (the indicator light does not light), call tech support. Pressurized booth: Check for alarm faults and warnings.
The booth is not operating at the correct temperature (booths with AMU option)	Incorrect temperature selector setting	Adjust the temperature to represent the exit air temperature of the AMU.
	Too much airflow	See the next troubleshooting symptom, "There is too much airflow."
There is too much airflow	Exhaust filters are not properly seated	Check that all filters are in place.
The booth has too much negative pressure	Exhaust filters are not properly seated	Ensure that all filters are in place.
	On pressurized booths, the intake filters may be dirty or obstructed	Change the filters. Remove any obstructions.
The exhaust fan motor overloads	Dirty filter	Replace the filters.
The manometer is not functioning properly	Low fluid level	Check the fluid level and add fluid as necessary.
	Obstructions in the hoses	Clear any obstructions in the hoses.
A light is not functioning properly	Front cover of light panel is dirty	Clean overspray. If light pane has pre-coating layers, peel a layer from the lens cover. If this is the last layer, replace pre-coat film.
	Light tube is burned out	Replace light tubes as required. This requires removal of front cover pane of the fixture (this may be a maintenance task depending on the specific installation's rules).

Spare parts and accessories

Consumable parts

GFS recommends that you keep the following consumable parts available:

- One change of filters for each filter type:
 - Exhaust filters
 - Intake filters
 - *If applicable:* AMU filters
- One box of light bulbs
- One roll of seal

Table 7. Consumable Parts

Part Number	Description
Refer to the Cabin Equipment Specifications on the General Arrangement drawing	Intake and exhaust filters
1052766	LED light bulbs (quantity of 4)
1011049	Manometer fluid (red)
1001854	Door sealing tape

Before ordering replacement parts, make sure you know the following:

- Serial number of your product
- Part number and description of the item you want to order
- Desired quantity of the item
- Purchase order number or credit card number
- Preferred shipping method (UPS, Federal Express, truck, air, etc.)
- Complete shipping and billing address

NOTE

Visit www.globalfinishing.com/parts-filters and the GFS Accessories Catalog for information about paint booth parts and components.

Accessories

Refer to the following table for commonly used accessories that can help keep your booth clean and organized.

Table 8. Accessories



Image	Name and description	Part number
 <p>The BoothBox 2 is a white, magnetic, double-compartment cabinet with a hinged lid. It is designed to hold two spray guns, one on each side. The interior compartments are visible, showing storage for supplies like tape and gloves. The unit is mounted on a base with two spray guns attached.</p>	<p>BoothBox 2™</p> <p>The BoothBox 2 is a magnetic, double compartment cabinet and double spray gun holder, designed for the interior of paint booths. With the BoothBox 2, you can store commonly used supplies — tape, gloves, tack cloth — within arm's reach, enabling you to increase productivity while eliminating time-consuming trips in and out of the booth.</p>	<p>1011508</p>
 <p>The Hose & Gun Hanger is a white, vertical stand. It features a top section with two spray guns hanging from a horizontal bar. Below the guns, there is a green roll of tape hanging from a hook. At the bottom, a red air hose is coiled around a base.</p>	<p>Hose & Gun Hanger™</p> <p>The Hose & GunHanger is a double spray gun holder and air hose hanger, designed for paint booths, prep areas, or mix rooms. It comes equipped with a hook for storing tape and other supplies.</p>	<p>1011518</p>



Image	Name and description	Part number
 <p>The image shows a white, L-shaped magnetic spray gun holder. It has a curved top edge and a hook at the bottom. A small American flag logo is visible on the front panel.</p>	<p>Single GunHanger™</p> <p>The Single GunHanger is a magnetic spray gun holder designed to hold all types of spray guns and most types of air tools. A soft edge guard eliminates scratching of the spray gun or gun cup.</p>	1011510
 <p>The image shows a white, vertical magnetic spray gun holder with four curved hooks at the top and two at the bottom. It has a locking mechanism on the side and a small American flag logo at the base.</p>	<p>4 GunHanger™</p> <p>The 4 GunHanger is a magnetic, four-position spray gun holder for paint booths, prep areas, or mix rooms. The 4 GunHanger is also equipped with a hook for storing spray guns, tape and other supplies, allowing you to avoid clutter and keep objects off the floor.</p>	1011516
 <p>The image shows a white, rectangular magnetic cabinet with two spray gun holders on the front. It has a small American flag logo on the front panel.</p>	<p>BoothBox Mini™</p> <p>The BoothBox Mini is a magnetic, single compartment cabinet and double spray gun holder, designed for the interior of paint booths. With the BoothBox Mini, you can keep commonly used supplies — tape, gloves, tack cloth — close at hand, enabling you to increase productivity while eliminating time consuming trips in and out of the booth.</p>	1011512







Image	Name and description	Part number
	<p>Booth Shield®</p> <p>Booth Shield protects booth interiors and increases brightness, improving visibility and overall product quality. Booth Shield coatings are easy to apply and quickly dry on your paint booth's walls, lights, and floors to trap overspray and create a safer spraying environment.</p>	<p>Walls:</p> <ul style="list-style-type: none"> • 1036906 (water-based wall prep; 1 gallon) • 1046355 (wall prep; 5 gallons) • 1036907 (clear, water-based; 1 gallon) • 1046353 (clear, water-based; 5 gallons) • 1036904 (white, water-based; 1 gallon) • 1046351 (white, water-based; 5 gallons) • 1046490 (white, water-based; 55 gallons) <p>Floor:</p> <ul style="list-style-type: none"> • 1033524 (water-based floor prep; 1 gallon) • 1036905 (white, solvent-based; 1 gallon) • 1046354 (white, solvent-based; 5 gallons) • 1046523 (white, solvent-based; 55 gallons)
	<p>PIG® Grippy Mats</p> <p>PIG Grippy Mat Paint Booth Protective Floor Covering has a self-sticking backing to securely protect the booth floor, while also trapping overspray, dirt, dust and particles for better quality paint finishes and a safe, bright working environment.</p>	<p>1054092 (32-inch x 150-foot roll)</p> <p>1054091 (32-inch x 100-foot roll)</p> <p>1054090 (32-inch x 50-foot roll)</p>
	<p>Light Fixture Lens Protector</p> <p>This clear, cling-on plastic film has a 2-millimeter thickness and is easy to apply and replace. Rolls are available in three widths and provide a crystal-clear protective coating.</p>	<p>1011214 (18-inch x 100-foot roll)</p> <p>1011121 (12-inch x 100-foot roll)</p> <p>1011122 (Dispenser Handle)</p>

Image	Name and description	Part number
	<p>Booth Paper</p> <p>Easily replaceable, fire-retardant lining for paint booth walls and floors. Rolls of Booth Paper are available in varying widths to efficiently cover your booth and protect the surface from paint and contaminant buildup, while the exposed surface prevents the migration of dust and overspray. Available in 80- and 100-pound weights.</p>	<p>1031284 (36-inch x 300-foot roll; 80# paper)</p> <p>1031283 (48-inch x 300-foot roll; 80# paper)</p> <p>1031282 (60-inch x 300-foot roll; 80# paper)</p> <p>1056424 (72-inch x 300-foot roll; 80# paper)</p> <p>1031281 (36-inch x 300-foot roll; 100# paper)</p> <p>1056629 (42-inch x 300-foot roll; 100# paper)</p> <p>1031280 (60-inch x 300-foot roll; 100# paper)</p> <p>1031279 (72-inch x 300-foot roll; 100# paper)</p> <p>1056078 (84-inch x 300-foot roll; 100# paper)</p>
	<p>DirtTrack Mat</p> <p>Prevent contaminants from entering the booth with GFS DirtTrack mats. Position the multilayered, adhesive mat in front of product or personnel doors to trap dirt and dust from shoes or tires. Once a sheet becomes soiled, it can be simply peeled off and discarded, leaving a fresh mat in its place.</p>	<p>1035254 (24-inch x 30-inch mats; 1 pad of 60 peelable sheets)</p> <p>1035255 (36-inch x 60-inch mats; 1 pad of 30 peelable sheets)</p>
	<p>Filter Insertion Tool</p> <p>Used to secure intake filters into the filter grid.</p>	<p>1011623</p>