

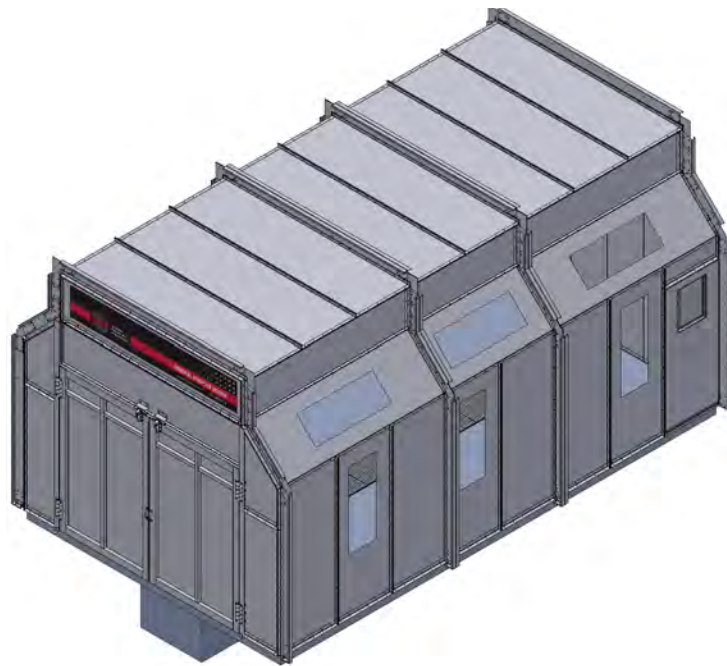

GLOBAL
FINISHING
SOLUTIONS



General Purpose: Pressurized Downdraft Booth

Installation Manual

Document Number: 239-029 rev 5
Publication date 03/01/2024

Read and keep this manual for future reference. All personnel operating the equipment described in this manual should review and understand all instructions before use.

Table of Contents

Introduction	5
About Global Finishing Solutions LLC	5
Contacting Global Finishing Solutions	5
Target audience	5
Conventions used in this manual	6
Safety notices	6
Information notices	6
General safety	7
Booth safety	9
Booth description	12
Preparing for installation	13
Accepting delivery of your booth	13
Gathering required documentation	14
Confirming site requirements	15
Collecting data from the Design Drawings	16
Booth dimensions	16
Bay layout	16
Identifying your AMU configuration	17
About the Design Drawings document	18
Page elements	18
Page types	20
Required materials	22
Required tools	22
Recommended equipment	23
Installation best practices	24
Unpack in stages	24
Sort and label	25
Using the part number	25
Using the item number	26
Follow assembly guidelines	27
Installation procedure	28
Prepare the floor	28
Prepare the pit	29
Build the front corners of the booth	29
Build the right front corner	30
Build the left front corner	31
Build the front end wall	32
Install the door frame for the front product door	33
<i>If applicable:</i> Install the frame for a roll-up door	34
<i>If applicable:</i> Install the frame for a non-roll-up door	35
Assemble the bays	35

Build the front bay	36
Build a center bay	39
Build the rear bay	44
Build the rear end wall	49
<i>If applicable:</i> Install the door frame for the rear product door	50
Anchor the booth	50
Install product doors	51
<i>If applicable:</i> Install a roll-up door	51
<i>If applicable:</i> Install a non-roll-up door	51
Install personnel doors	54
Mount the door	54
Attach the handles	54
Install the Brixon safety latch	55
Install door seals	56
Install the exhaust fan(s)	57
Assemble the exhaust stack(s)	58
<i>If applicable:</i> Install spiral duct with Automatic Roof Ventilator (ARV)	58
<i>If applicable:</i> Install plain duct with Automatic Roof Ventilator (ARV)	60
<i>If applicable:</i> Install the guy-wire kit	61
<i>If applicable:</i> Install an above-booth AMU	62
<i>Above-booth AMU:</i> Install the AMU discharge duct	62
<i>Above-booth AMU:</i> Assemble the AMU stand	63
<i>Above-booth AMU:</i> Install the AMU unit	63
<i>Above-booth AMU:</i> Install the AMU intake duct and hood	64
<i>If applicable:</i> Install a roof-mounted AMU	64
<i>Roof-mounted AMU:</i> Install the AMU discharge duct	64
<i>Roof-mounted AMU:</i> Install the AMU unit	65
<i>If applicable:</i> Install a vertical AMU	66
<i>Vertical AMU:</i> Assemble the AMU stand	66
<i>Vertical AMU:</i> Install the AMU unit	66
<i>Vertical AMU:</i> Install the AMU ductwork	67
Install the lights	68
Install cage nuts in the light fixtures	68
Install light fixtures in panels	68
Install covers over light fixtures	70
Install the manometer	70
Install the control panel	71
Install miscellaneous electrical devices	73
Install proximity switches	73
<i>If applicable:</i> Install the air-sensing tube	76
<i>If applicable:</i> Install the air-proving switch	77
Install the temperature sensor	77
Install the air solenoid valve	79
<i>If applicable:</i> Install the Economy Mode switch	80
<i>If applicable:</i> Install the gun hanger switch	80
Caulk the booth	82
Perform electrical hookup	82
Wire miscellaneous electrical devices	82
<i>If applicable:</i> Install junction box & disconnect switch for roll-up door	82
Install filters	83
Install the intake filters	83

Assemble the pit and install the exhaust filter media	84
Startup resources	86
Startup tools and test equipment	86
Hand tools	86
Test equipment	86
Optional equipment	86
Complete the Customer Pre-Startup Checklist	87
Perform the startup procedure	87

Introduction

About Global Finishing Solutions LLC

Leading the Industry in Paint Booth and Finishing System Technology

With decades of experience, Global Finishing Solutions is the leading manufacturer of paint booths and finishing systems for many industries, including automotive refinish, aerospace and defense, industrial manufacturing, woodworking, and large equipment. By combining high-quality components, strong relationships with paint manufacturers, and our experienced distribution network, GFS provides the best equipment and support to set your business up for success.

Contacting Global Finishing Solutions

General information

- Toll-free: 800-848-8738
- Fax: 715-597-2193
- Email: info@globalfinishing.com
- Online: www.globalfinishing.com

Technical support

- Toll-free: 800-848-8738
- Fax: 715-597-8818
- Email: techservices@globalfinishing.com

Parts and filters

- Toll-free: 800-848-8738
- Fax: 888-338-4584
- Email: parts@globalfinishing.com

Target audience

This document is intended for use by trained, experienced paint booth installers and maintenance technicians. If you have questions about the installation procedure described in this manual, contact GFS as described above.

Conventions used in this manual

This section describes how information is presented, organized, and referenced within this manual.

Safety notices

This manual uses the following standards to identify conditions related to safety hazards and equipment damage.

Table 1. Safety notices

Symbol	Description
DANGER	Indicates an imminent hazard that will result in death.
WARNING	Indicates a hazard that can result in serious personal injury or death.
CAUTION	Indicates a hazard that can result in personal injury.
NOTICE	Indicates a situation that can result in equipment or property damage, but poses no risk of personal injury.

Information notices

In addition to the safety notices described above, this manual uses a boldface keyword to identify certain other types of information.

Table 2. Information notices

Keyword	Description
NOTE	Denotes general information that provides additional context or guidance.
Important	Denotes information to which you should pay special attention.
Reference	Directs you to related content in a separate document.
Prerequisites	Specifies other tasks that must be completed or conditions that must exist before you perform the current task.
Scope	Describes limitations to the current task or conditions under which the task applies or does not apply to the procedure.

General safety

Follow all safety guidelines when assembling, operating, or servicing this product.

WARNING

There are inherent hazards associated with the operation and service of this equipment. For your personal safety, observe all safety information. Failure to observe these safety practices can result in personal injury or death.

WARNING

Operation and maintenance of this product must be performed properly by qualified personnel who observe the warnings in all documentation and notes provided with and on the product.

WARNING

Follow all general standards for installation and safety for work on installations. Follow all good practices for the proper use of lifting tackle and equipment. The use of protective equipment such as safety goggles and protective footwear must be considered.

WARNING

All persons who will operate, service, inspect, or otherwise handle this product must read and understand the safe operating practices, safety precautions, and warning messages in this documentation.

WARNING

The roofs of GFS equipment are not designed or intended to be walked upon or to support weight of any kind. As designed and manufactured, equipment roofs do not meet the minimum requirements of a safe walking and/or working surface under OSHA 1910.22. Under no circumstances should the roof be used by maintenance personnel or others for walking, standing, or storage of any kind. When necessary, roof access should be secured through the use of a properly supported platform that satisfies the minimum load requirements specified by ASCE 7 (Minimum Design Loads and Associated Criteria for Buildings and Other Structures) and ASCE 37 (Design Loads on Structures during Construction). Additionally, personnel should always utilize appropriate fall safety protocols when using an elevated platform. Use of the roof in a contrary manner may result in injury and/or death.

WARNING

Comply with OSHA guidelines and with all applicable local electrical, safety, and fire codes and standards.

WARNING

All field wiring provided must comply with local codes or, in the absence of local codes, the National Electrical Code (NFPA 70). Article 516 covers applicable of flammable and combustible materials.

WARNING

Electrical installation should be completed by a qualified electrician. Installation must meet all applicable national, state, and local electrical codes.

WARNING

Ensure that all electrical components are grounded to a central ground.

WARNING

Disconnect and lock out the main electrical service before installing, adjusting, or servicing the product.

WARNING

Guards and covers that prevent contact with electrically energized or moving parts are required and must not be removed or left open during operation.

WARNING

Welding, cutting, and other spark-producing operations shall not be permitted in or adjacent to a booth until a written permit authorizing such work has been issued. The permit shall be issued by a person in authority following his or her inspection of the area to ensure that precautions have been taken and will be followed until the job is completed.

WARNING

Local fire and building codes require fire protection. Check with local inspector authorities for requirements.

CAUTION

Read and save these instructions before attempting to assemble, install, operate, or maintain the product described. Protect yourself and others by observing all safety information. Failure to comply with instructions could result in personal injury and/or property damage. Retain these instructions for future reference.

CAUTION

This manual contains statements that relate to worker safety. Read this manual thoroughly and comply as directed. Operate this equipment in accordance with the guidelines set forth in this manual. It is impossible to list all potential hazards of this equipment. Instruct all personnel involved with this equipment in the safe conduct and operation of the system. GFS recommends that only qualified personnel operate and maintain this equipment.

CAUTION

Safety signs, panels, and labels that are normally affixed to the product must be replaced immediately if illegible or missing.

CAUTION

New or replacement parts that are installed during repair or maintenance must include all safety signs, panels, and labels as specified by the manufacturer. These must be affixed to the new or replacement parts as specified by the manufacturer.

CAUTION

Where applicable, use earplugs or take other safety measures for hearing protection.

NOTICE

The product must be installed and serviced only by a trained, qualified service technician. Incorrect installation may void the warranty.

NOTICE

If you have questions about the warranty, please contact your distributor prior to contacting GFS.

Booth safety

DANGER

Ceiling panel load capacity for installation and maintenance: You must use temporary platforms that span at least two structural frames for maintenance. **Do not walk on or apply any pressure to lights or explosion (deflagration) relief panels.**

WARNING

All equipment must be operated and maintained in accordance with local, state, and federal (OSHA) requirements governing occupational safety, fire protection, and booth operations. Operators must read and understand GFS and included independent equipment and/or component manufacturer's instructions prior to use. **Disclaimer:** GFS is not responsible for any injury, illness, or property damage that results from not abiding by local, state, or federal (OSHA) requirements that govern occupational safety, fire protection, and booth operations. GFS is also not responsible for any injury, illness, or property damage that is the result of not adhering to GFS and/or independent equipment/component operating, service, maintenance, and/or installation requirement's or directives.

WARNING

Install the booth in compliance with locally enforced codes and standards.

WARNING

A fire suppression system is required by the International Fire Code and NFPA 33. A fire suppression system is not supplied with this booth.

WARNING

Do not allow overspray to accumulate on the inside of the paint booth walls. When overspray accumulates, remove it as soon as possible to prevent a possible fire hazard. Use a non-ferrous, non-sparking scraper to eliminate any possibilities of igniting combustible material.

WARNING

Do not leave piles of paint sweepings in the booth as it creates a possible fire hazard.

WARNING

Treat used filters and any other paint-contaminated items as flammable products and dispose of them safely.

WARNING

If coatings containing nitrocellulose are sprayed in the booth, all residue must be removed from exhaust diffuser components and all exhaust filters must be changed at least once a day.

WARNING

Improper disposal of used filters may cause spontaneous combustion. You must consult local authorities for proper storage and disposal requirements. Guidelines include:

- Immediately remove all contaminated filters from the paint booth.
- Discard filters to a safe, detached location, place them in a non-combustible container with tight-fitting lid, or place them in a water-filled metal container to prevent a possible fire hazard.
- Disposal varies depending on the type of paint that is being captured. Consult local authorities for storage and disposal requirements.

WARNING

Duct the exhaust air from the fan away from the working environment to the outdoors. Do not operate the booth unless exhaust has been ducted properly.

WARNING

Isolate the outdoor vent from air-conditioning intakes, windows, and any other equipment that may recirculate the exhaust indoors.

WARNING

Turn on the exhaust fan before using the booth. Ensure that the exhaust fan is operating correctly before entering the booth.

WARNING

Check local codes to see if a booth interlock is required. A booth interlock prevents the spray devices from operating unless the exhaust fan is operating.

WARNING

Some spray activities may require the use of respiratory protection.

WARNING

Use an OSHA-approved paint spray respirator when spraying in the booth.

WARNING

Do not operate the booth when the manometer indicates the filters need to be replaced.

WARNING

Do not overfill the manometer. Overfilling allows fluid to collect in the flexible plastic connecting loop in the back of the manometer, which could cause a serious reading error. If the manometer is subject to overflow, make sure that the fluid has not passed into the plastic connecting loop.

WARNING

This equipment is designed for the removal of particulate matter only. Reduction of volatile organic compounds (VOCs) requires either coating reformulation or optional, additional equipment.

WARNING

Fall Hazard: Do not walk or drive over the pit without the bar grating in place.

WARNING

Fall Hazard: Do not drive over the bar grating in a vehicle that exceeds the maximum wheel load listed in the Bar Grating Specification table on the Pit Details page of the Design Drawings.

WARNING

Fall Hazard: Do not remove bar grating from the pit unless authorized to do so. The pit presents a fall hazard when the bar grating is not installed.

WARNING

For spray booths with an elevated temperature cure mode, any containers of ignitable (flammable or combustible) liquids shall be removed from the booth before the Air Make-Up Unit is energized.

CAUTION

Become familiar with all controls before operating or servicing this booth.

CAUTION

Proper door alignment is critical to the operation of the booth. Ensure that there is equal space around the doors. Move the bottom of the door jamb to the left or right or in and out until the doors are sealed and plumb.

CAUTION

If this installation includes pumps or compressors, install and connect those devices in accordance with the manufacturer's documentation.

NOTICE

GFS recommends storing crates indoors pending installation. If you must store crates outside, protect crates and their contents from moisture to prevent damage to equipment.

NOTICE

Install the control panel per NFPA 70 and local codes and standards.

NOTICE

Failure to anchor the booth structure to the floor properly may result in structural damage.

NOTICE

GFS does not provide materials for constructing the pit. It is up to the customer to arrange for the actual construction of the pit.

Booth description

Generally accepted as the best airflow style, downdraft booths do an excellent job controlling overspray and contamination. Air enters the booth through a filtered ceiling plenum, flows vertically over the product, and into the filtered exhaust pit in the floor.

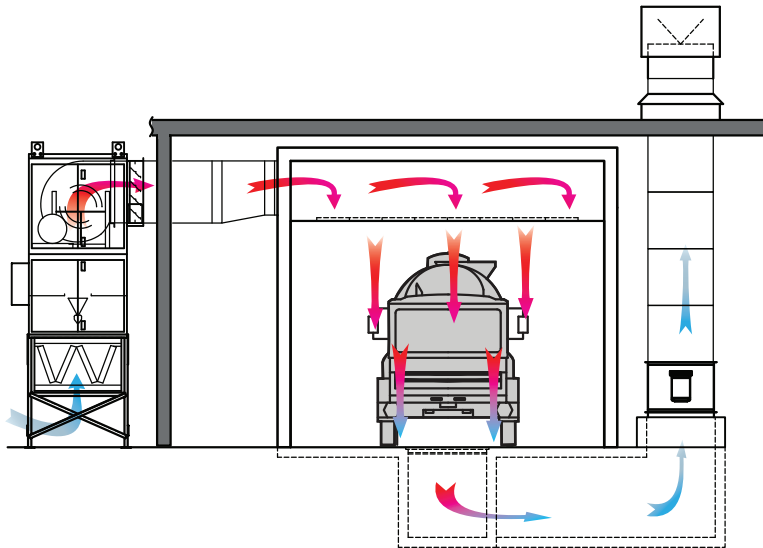

Figure 1. Airflow in a pressurized Downdraft booth. (Your booth may have a different AMU configuration than shown here.)

Preparing for installation

Accepting delivery of your booth

The booth is delivered unassembled, in multiple crates.

Upon delivery, count the number of crates you received and compare that number to the expected number per the Bill of Lading. Also inspect each crate for any signs of damage during shipment.

NOTE

If you see shipping damage, note it on the freight carrier's paperwork; failure to do so may result in claim denial.

If any parts are missing or damaged, contact Global Finishing Solutions at 800-848-8738 to speak to a Technical Service Representative.

NOTICE

GFS recommends storing crates indoors pending installation. If you must store crates outside, protect crates and their contents from moisture to prevent damage to equipment.

Gathering required documentation

Ensure that you can locate these documents and that they are available during the installation procedure.

NOTE

Certain manuals, project drawings, and the Job-Specific Guide are also provided electronically to distributors via box.com. Many manuals are available for download on globalfinishing.com.

Table 3. Additional documentation

Document	Description	How provided
Design Drawings	Provides instructions for assembling this particular booth and includes information about the booth order, configuration, and components.	Ships in the "Miscellaneous" box
General Booth Details	Provides drawings and assembly instructions for common components; may include drawings that do not apply to this particular booth.	Ships in the "Miscellaneous" box
Electrical Drawings	Provides wiring diagrams for electrical components. NOTE Electrical Drawings are provided only if the booth includes a control panel from GFS.	Ships inside the control panel
Control Panel Operator Manual	Setup and operation instructions for the control panel.	Ships inside the control panel
Startup documents	A set of documents related to booth startup and commissioning.	Ships in the "Miscellaneous" box

Confirming site requirements

Before beginning the installation procedure, confirm that the site where the equipment will be assembled meets the following requirements:

- The floor where you will assemble the paint booth is level.

NOTE

If the floor is more than 1/4 inch out of level, you must shim or grout the floor to avoid any misalignment.

- The area is large enough to allow a minimum of 3 feet (914 mm) of clear space on all four sides of the booth, taking into account if additional space is needed for an air heater or Air Make-Up Unit. Check local codes and refer to NFPA guidelines to determine particular space allowances.
- There is sufficient overhead clearance for an exhaust unit and the exhaust ductwork in the area where the equipment is to be located.
- If the AMU will be installed on top of the booth, there is sufficient overhead clearance for the AMU. All AMUs must have a minimum of 36 inches of clear area in front of the access door for maintenance.
- The pit is already constructed and meets the following criteria:
 - The dimensions of the pit correspond to the site drawings provided by GFS.
 - The pit is situated so that the booth can be centered over the pit and still have the required clearances.
- A licensed electrician has verified that the incoming power meets the requirements specified for the equipment. (The power specification is included with the submittal or provided at delivery.)
- The appropriate devices for lifting/rigging are available onsite. (Either purchased from GFS with the booth, or obtained elsewhere by the customer.)
- The appropriate miscellaneous hardware kits are available on-site. (Either purchased from GFS with the equipment, or obtained elsewhere by the customer.)

Collecting data from the Design Drawings

This section helps you locate important data in your Design Drawings document and collect it in one place for easy reference during installation.

NOTE

For information about the Design Drawings document, see “About the Design Drawings document” (page 18).

Booth dimensions

Collect information about your booth’s footprint from the Design Drawings document and record it in the following table:

Table 4. Booth dimensions

Dimension	Value
Working Width ¹	
Working Depth ²	
Clearance Width ³	
Clearance Depth ³	

¹Refer to the “Working Width” value on the Front Elevation view on the Concept page of the Design Drawings.

²Refer to the “Working Depth” value in the Side Elevation view on the Concept Drawing page of the Design Drawings.

³Refer to the clearance values in the Plan View on the Concept page of the Design Drawings.

Bay layout

Collect information about your booth’s bay layout from the Design Drawings and record it in the following table:.

Table 5. Bay layout

Total number of bays: ¹ _____			
Build order ^{2,3}	Depth ⁴	Rear bay: Door position (left/right) ^{5,6}	AMU duct connection? ^{7,8}
1 (front bay)		n/a	
2		n/a	
3			
4			

¹To determine the total number of bays in your booth, refer to the Plan View on the Overall Assembly page of the Design Drawings.

²This table provides space for up to four bays. If your booth design does not include that many bays, leave unused rows blank.

³When constructing the booth, build bays in order from front to back of the booth.

⁴To determine the depth of a particular bay, refer to the Plan View on the Overall Assembly page of the Design Drawings.

⁵A standard General Purpose booth contains one personnel door located in the rear-most bay (i.e., in the last bay to be built, since assembly proceeds from front to back).

⁶To determine door placement, refer to the Plan View on the Overall Assembly page of the Design Drawings and look for door openings. Door openings on the upper side of that drawing correspond to doors on the left side of the booth (when facing the booth from the front); door openings on the lower side of that drawing correspond to doors on the right side of the booth (when facing the booth from the front).

⁷This column applies to a pressurized booth only. If you have a non-pressurized booth, leave this column blank.

⁸Pressurized booth only: The AMU ductwork connects into one of the bays. To determine which bay requires the ductwork connection, refer to the Overall Assembly page of the Design Drawings.

Identifying your AMU configuration

This installation manual includes instructions for installing various configurations of an Air Make-Up Unit (AMU), including:

- Horizontal AMU mounted above the booth
- Horizontal roof-mounted AMU
- Vertical AMU with side-entry into the booth
- Vertical AMU with top-entry into the booth

IMPORTANT: Within the installation procedure, you are directed to perform or skip certain tasks, or certain steps within tasks, based on your AMU configuration. Therefore, make sure you know which AMU configuration your booth uses before you begin the procedure.

To gather information about your AMU, refer to the following resources:

- The “AMU Specifications” table on the Concept Drawing page of the Design Drawings
- The drawings on the Concept Drawing, Overall Assembly, and AMU Kit pages of the Design Drawings
- The AMU manufacturer’s documentation, which ships inside the AMU control panel.

Table 6 lists some general characteristics of each AMU configuration.

Table 6. AMU configurations

AMU orientation	Where installed	Entry into booth ^{1,2}	AMU stand?	Dis-charge duct? 3	Intake duct? ⁴	Intake hood?
Horizontal	Above-booth	Top	Yes	Yes	Yes	Yes
Horizontal	Roof-mounted	Top	No	Yes	No	Yes ⁵
Vertical	Indoors (beside booth)	Top or side ⁶	Yes	Yes	Yes	Yes
Vertical	Outdoors (be-side building)	Top or side ⁶	Yes	Yes	No	No

¹The term “entry into booth” refers to the location where the AMU ductwork penetrates the booth: either on the top of the booth or on the side of the booth. Some installation steps are specific to the type of booth entry.

²Depending on the type and size of your booth, the AMU ductwork may penetrate the booth in more than one place. In that case, all penetrations will be of the same type (i.e., all top or all side).

³The AMU discharge duct goes between an intake opening at the booth and the discharge opening on the AMU unit.

⁴The AMU intake duct goes from the intake opening on the AMU unit to the intake hood.

⁵For a roof-mounted AMU, the intake hood is part of the AMU.

⁶A vertical AMU might enter the booth from the top or from the side, depending on the type and size of the booth. To determine whether a vertical AMU uses top- or side-entry, refer to the drawings on the Concept Drawing and Overall Assembly pages of the Design Drawings.

About the Design Drawings document

Use this manual in conjunction with the provided Design Drawings document. This Design Drawings document defines the overall layout and detailed structure of your particular booth. If applicable, it also includes exploded-view diagrams and parts lists for each section (or subassembly) of the booth.

Page elements

Pages within the Design Drawings document contain the following elements:

- **Title block:** The title block is located along the right edge of each page. It contains the model information, drawing identification label or number, the order/serial number, and other information.
- **Model Info:** Contains text that identifies each page within the Design Drawings document, e.g., "Overall Assembly". When the installation instructions refer you to a specific page within the Design Drawings, look for that text in the Model Info field. (For a description of the various page types that might be included in your Design Drawings document, see "Page types" (page 20).)
- **Scale:** If the drawing is to scale, the scale is defined here (e.g., 3/16" = 1' 0"). Otherwise, this field contains "NTS," or "Not to Scale."
- **Drawings:** The main area of each page can contain any or all of these types of drawings:
 - An exploded and/or assembled view of the product or subassembly
 - Additional views or "Detail" drawings
- **Bill of Materials:** Any page that includes a drawing with labeled parts also includes a table that lists each item number with its corresponding part number and quantity.
- **Quantity per Booth:** Pages that show a subassembly of the product and list the quantity provided of that particular subassembly.
- **Notes:** Pages within the Design Drawings often contain notes that provide information about how to install that particular section or subassembly.

Page types

The Design Drawings document may contain any of the following pages that apply to your particular product.

Table 7. Page names in the Design Drawings document

Page name	Description
AMU Kit	Provides installation instructions for installing the Air Make-Up Unit (AMU). If ductwork was included with your order, this page also provides instructions for the AMU ductwork.
AMU Stand	Provides instructions for installing a stand for an AMU.
Bay Assembly	Instructions for assembling each type of work bay included in your booth.
Chamber Wall	Shows an exploded view of an exhaust bridge chamber's back wall; applies only to cross-draft and semi-downdraft booths that are not drive-through.
Concept Drawing	Shows a top view of the booth (labeled "Plan View"), as well as front, side, and back elevations.
Cover Page	Provides the product name and description, the customer name, the shipping location, and a table of contents for the Design Drawings document. NOTE This is always the first page of the Design Drawings document.
Diffuser Assembly	Provides instructions for installing a diffuser for a booth that uses a vertical AMU with side-entry into the booth; typically on General Purpose booths.
End Wall	Shows an exploded view of the booth's front or back wall. The front wall is always drive-through (DT) style to accept a product door; the back wall can be drive-through or solid-back (SB) style, depending on how your booth is configured.
Exhaust Bridge Chamber	Shows an exploded view of an exhaust bridge chamber; applies only to crossdraft and semi-downdraft booths.
Filter Wall	Shows how to assemble a filter wall; applies to non-pressurized crossdraft booths, only.
General Structural Notes	Shows how to anchor various booth components to the slab.
GP Double Frame	Shows assembly instructions for the framing that goes between adjacent bays in a General Purpose (GP) booth. A "GP Double Frame" page may be further classified as "P" (pressurized) or "N" (non-pressurized).
GP Single Frame	Shows assembly instructions for the framing that goes between a bay and an end wall in a General Purpose (GP) booth. A GP Single Frame page may be further classified as "P" (pressurized) or "N" (non-pressurized).
Intake Bridge Chamber	Shows an exploded view of an intake bridge chamber; applies to pressurized crossdraft booths, only.
Intake Duct Box Assembly	Shows an exploded view of an intake duct box; applies only to pressurized booths that use an indoor vertical AMU.
Overall Assembly	Shows an angled front view and a back view that identify the booth sections, plus a top view (labeled "Plan View") that shows bay dimensions and door locations.
Perforate Layout	Provides instructions for installing perforated panels for a booth that uses a vertical AMU with side-entry into the booth; typically applies to Large Equipment side downdraft and downdraft booths.
Pit Assembly	Shows how to install bar gratings and filter media in the pit; applies only to downdraft booths.
Pit Detail	Provides instructions for constructing the pit required for a downdraft booth. (Customers are responsible for constructing the pit prior to booth installation.)

Page name	Description
Product Door	<p>The Design Drawings document includes a page for each type of product door included in your booth; the options are:</p> <ul style="list-style-type: none">• Product Door - Solid• Product Door - Filter• Roll Up Door Kit• GP Roll Up Door Kit
Side Chamber	<p>Shows an exploded view of an exhaust chamber that is located along the side of the booth; applies only to side downdraft booths.</p>
Structure Assembly	<p>Shows assembly instructions for the columns and beams that form the frame of a Large Equipment booth; the Design Drawings package includes one Structure Assembly page for each type of column/beam set.</p>

Required materials

This section lists the tools, equipment, and documentation required for installing your booth.

NOTE

Depending on the type of equipment you are installing, additional tools may be required.

Required tools

- Screwdrivers
- Wrenches and socket set
- Hammer and mallet
- Drift pins (two per person; 1/8-inch to 5/8-inch taper)
- Caulk gun
- Impact driver and drill
- Chalk and/or felt-tip marker (for marking initial measurements on floor)
- Chalk-line tool
- Laser level (*Suggested:* Quad laser or rotary laser level)
- Tape measures (35-foot and 100-foot)
- Drill with 1/8-inch, 3/8-inch, and 1/2-inch bits
- Torque nut runner
- Reciprocating saw
- *Optional:* Torch and welder in case modifications need to be made on site

Recommended equipment

- Ladders
- Material handler
- Two 26-foot T scissor-lift platforms
- Warehouse forklift with 5000-pound lift weight and a maximum lift height higher than 16 feet
- *If applicable to your booth configuration:* 6000-pound Lull forklift to set the air make-up unit (AMU) on top of the booth; or a crane to set the AMU on top of the building

NOTE

Lifts and cranes are not required, but they may improve both the safety and speed of installation.

NOTE

The end user is responsible for providing any lifts, cranes, and material handlers. Alternatively, the end user can coordinate with the installer so the installer can rent those items before starting the work.

Installation best practices

Unpack in stages

As you begin each section of the installation procedure, unpack the crate(s) that contain the parts for that section. In general, the skids are organized so the parts that go together during assembly are packed on the same skid.

NOTE

For faster unpacking, use a reciprocating saw to cut the crates.



Figure 2. Skids awaiting unpacking

A packing list is attached to each crate. As you unpack a crate, compare all the parts with that crate's packing list to check for shortages or losses in transit. Also check parts for any damage that might have been caused in shipping.

NOTE

Slightly bent panels and angle braces can be straightened and will cause no performance or assembly problems.

If any parts are missing or damaged, contact Global Finishing Solutions at 800-848-8738 to speak to a Technical Service Representative.

Sort and label

To help installation proceed more efficiently, sort booth panels and tie angles by size as you unpack them (Figure 3).

For best results:

- Use the *part number* to help identify components as you sort them.
- Label each part with its corresponding *item number* so you can select the correct parts quickly during assembly.



Figure 3. Panels sorted by size in preparation for assembly

Using the part number

If in doubt whether two parts are equivalent, check the *part number*. The part number is either etched into the part or printed on a label affixed to the part (Figure 4).

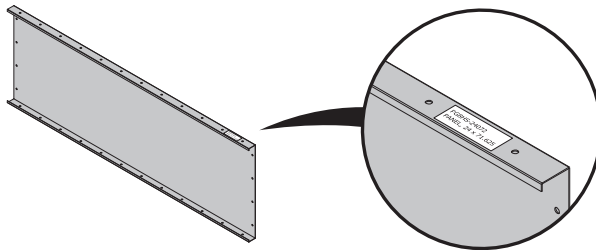

Figure 4. Example of a part number label

Using the item number

To make it easier to identify a part in relation to the Design Drawings document, identify each part by its *item number*.

To find the item number, look on the Design Drawings document page where that part is used and find the part number in that page's Bill of Materials. Then find the corresponding item number.

For example, in Figure 5, part number PG8HS-24072 corresponds to item number 18. (The numbers on your Design Drawings may be different than shown here.)

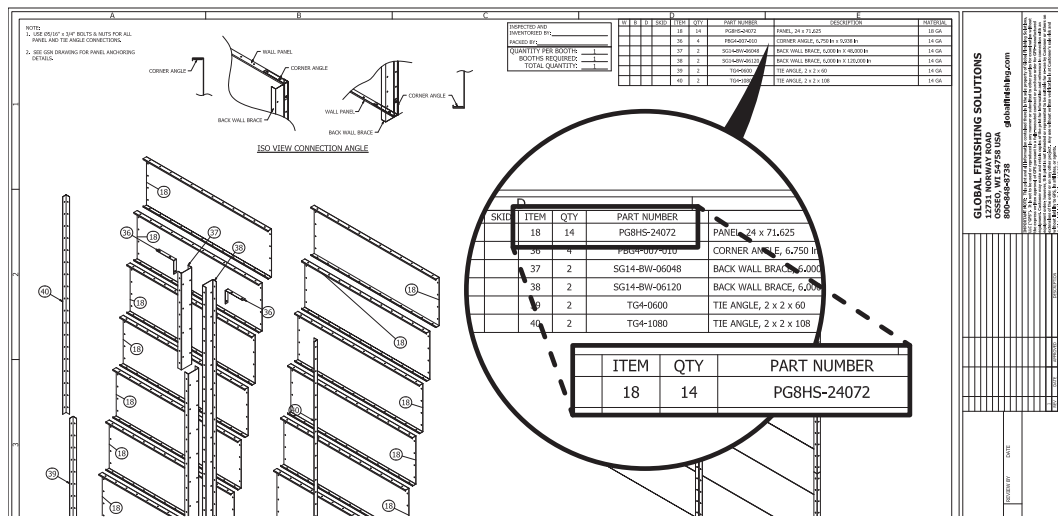

Figure 5. Example of finding the item number that corresponds to a part number

Once you've found a part's item number, write the item number on that part with a marker (Figure 6).

NOTE

Be sure to write the item number in a location that will not be visible after the booth is assembled (for example, on a flange).

Labeling parts with their corresponding item numbers does require more set-up time, but you'll be able to find parts more quickly, with less chance of selecting the wrong part during assembly.

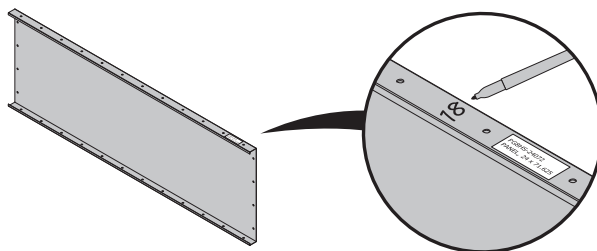

Figure 6. Example of an item number written on a panel flange

Follow assembly guidelines

Follow these guidelines when assembling the booth:

- Assemble the booth in sections, working from front to back.
- As you build each section, tighten the bolts only to finger-tight.
- When directed to do so, tighten the bolts within a section to *snug-tight*. Snug-tight is defined as “the tightness that is attained with a few impacts of an impact wrench or the full effort of an ironworker using an ordinary spud wrench to bring the plies into firm contact.” (RCSC 2014)
- Orient panels so that each panel’s flanged side faces outward, and the non-flanged side faces the interior.
- Orient bolts so that the bolt heads are on the interior and the threads are on the exterior. At corners where an assembly angle is used, place the nuts on the inside of the panel flanges.
- Use 5/16-inch by 3/4-inch bolts and nuts for all tie angle and panel connections. Use other hardware as specified within the installation instructions or on the Design Drawings.
- Plumb the panels so that they are perpendicular to the floor. The sides of the booth must be parallel to each other.

Installation procedure

This procedure describes how to install a pressurized downdraft General Purpose Paint Booth.

Prepare the floor

Prerequisites: The customer must have already constructed the pit in accordance with the specifications on the Pit Detail page of the Design Drawings.

1. Sweep the floor clear of debris.
2. Use a laser level to check the floor:
 - If the floor is out of level by **1/4 inch or less** over the full length of the booth, continue to the next step. (You do not need to take any corrective action now because you can use the supplied shim pack to correct for slope when installing frame assemblies later in the procedure.)
 - If the floor is **more than 1/4 inch** out of level over the full length of the booth, shim or grout the floor as needed to get it to within 1/4 inch of level. GFS does not supply shims for this purpose.
3. Referring to the Working Width and Working Depth you recorded in “Collecting data from the Design Drawings” (page 16), measure the booth’s footprint on the floor and mark the corners.

NOTE

Position the footprint so that it is centered (lengthwise) over the pit.

NOTE

Ensure that the location allows for the clearances specified in “Confirming site requirements” (page 15).

NOTE

Use a piece of chalk or other temporary mark at this stage, in case you have to adjust the position of the marks in the next step.

4. Measure the diagonals to confirm that the opposite sides are parallel and that adjacent sides are perpendicular to each other.

Re-measure and adjust the corner markings as needed until the diagonals are equal length.

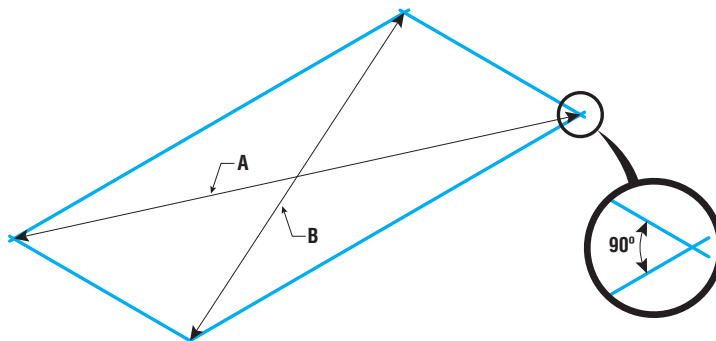

5. After confirming that the measurements are correct and the angles are 90 degrees, snap chalk lines to mark the outline of the booth's footprint.

Prepare the pit

Prerequisites: The customer must have already installed the pit in accordance with the specifications on the Pit Detail page of the Design Drawings.

Reference: Refer to the Pit Assembly page of the Design Drawings.

IMPORTANT

The images below provide *general* building instructions and design concepts. **Always refer to the appropriate page in the Design Drawings** for guidance on your *specific* booth.

1. Place the bar grating in the pit.

NOTE

Grating must be installed with cross rods on top.

NOTE

You can walk and drive over the pit after the bar grating is installed.

WARNING

Fall Hazard: Do not drive over the bar grating in a vehicle that exceeds the maximum wheel load listed in the Bar Grating Specification table on the Pit Detail page of the Design Drawings.

2. Cover the pit with plywood to prevent debris from collecting in the pit during assembly.
3. Cover the exhaust stack opening(s) with plywood and mark them as a hole so no one will drive over them.

Build the front corners of the booth

Prerequisites: The booth's footprint must be marked on the floor as directed in "Prepare the floor" (page 28).

Reference: You will need to refer to several Design Drawings pages while building the front corners, including pages for the bay, frame, and end wall:

- **For the bay:** Use the Plan View on the Overall Assembly page to identify the size of the front bay (either 6-foot or 9-foot depth). Then refer to the Bay Assembly page for that size bay with no doors ("0D").
- **For the frame:** Refer to the GP Single Frame page for details on frame assembly.
- **For the end wall:** Refer to the Overall Assembly page to determine what type of product door is specified for the front of the booth (either roll-up or non-roll-up). Then refer to the appropriate End Wall page for details:
 - **DT-RU:** Drive-Through Roll-Up end wall, for use with a roll-up door
 - **DT:** Drive-Through end wall, for use with a non-roll-up door

IMPORTANT

The images below provide *general* building instructions and design concepts. **Always refer to the appropriate page in the Design Drawings** for guidance on your *specific* booth.

Build the right front corner

1. Referring to the appropriate End Wall page of the Design Drawings, build the right-side pieces of the front end wall on the floor; then set the end-wall sub-assembly aside.

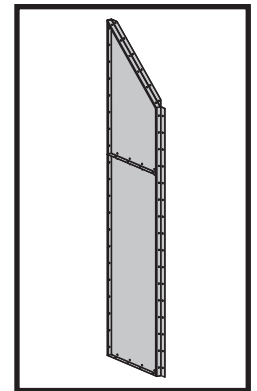
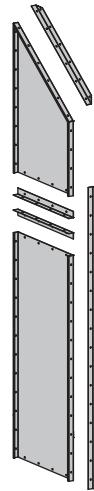

2. Referring to the GP Single Frame page, connect the single-frame pieces that will fit between the right side of the end wall and the bay; then set the single-frame sub-assembly aside.

NOTE

Use 1/2-inch x 1-inch bolts and nuts to connect corner plates to frame pieces.

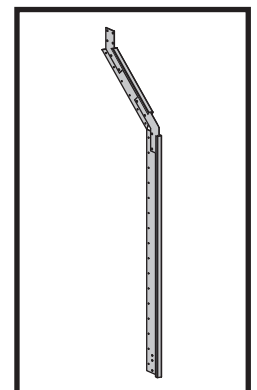
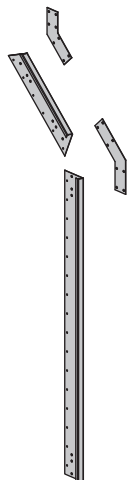

3. Referring to the appropriate Bay Assembly page, connect the front-most panel and tie angle of the right side wall on the floor; then set the side-wall sub-assembly aside.

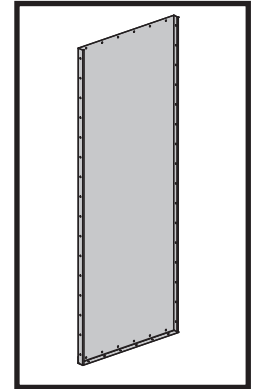
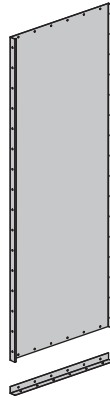

4. Connect the end-wall sub-assembly, the single-frame sub-assembly, and the side-wall sub-assembly to create the right front corner of the booth.

IMPORTANT

Orient the single-frame sub-assembly so that the flanged edges face the front of the booth.

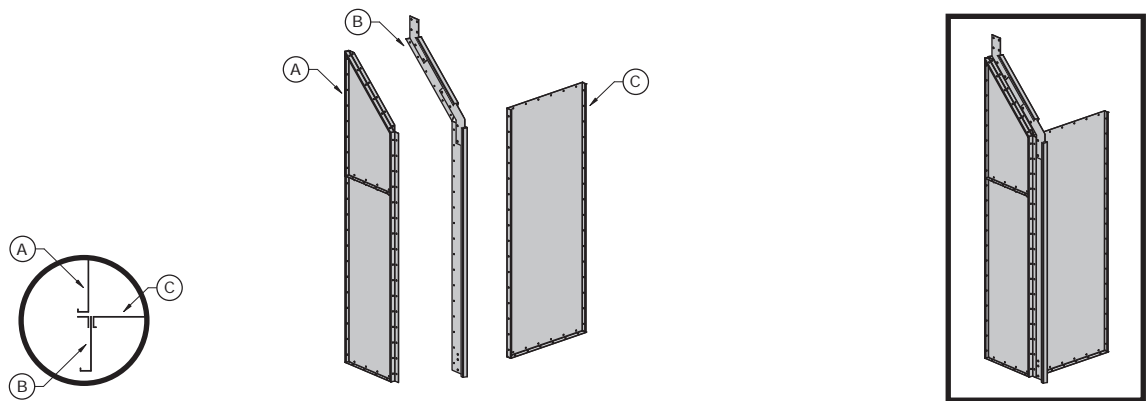

- A: End-wall sub-assembly
- B: Single-frame sub-assembly: Flanged edge must face the front of the booth
- C: Side-wall sub-assembly

Build the left front corner

NOTE

In this task, you will build the opposite front corner to the one you built in “Build the right front corner” (page 30).

1. Build the left-side pieces of the front end wall on the floor; then set the end-wall sub-assembly aside.
2. Connect the single-frame pieces that will fit between the left side of the end wall and the bay; then set the single-frame sub-assembly aside.

NOTE

Use 1/2-inch x 1-inch bolts and nuts to connect corner plates to frame pieces.

3. Connect the front-most panel and tie angle of the left side wall on the floor; then set the side-wall sub-assembly aside.

4. Connect the end-wall sub-assembly, the single-frame sub-assembly, and the side-wall sub-assembly to create the left front corner of the booth.

IMPORTANT

Orient the single-frame sub-assembly so that the flanged edges face the front of the booth.

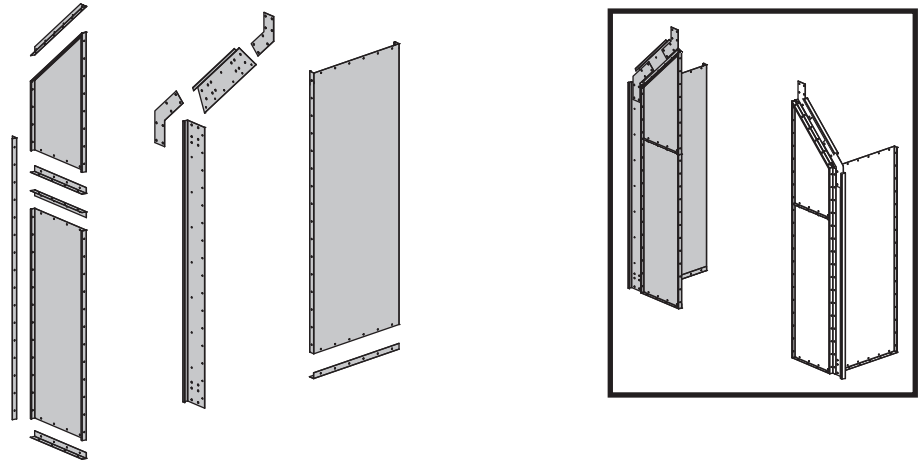

Build the front end wall

Prerequisites: The front corners of the booth must be assembled as described in “Build the front corners of the booth” (page 29).

NOTE

You assembled part of the front end wall in “Build the front corners of the booth” (page 29), as part of building the front corners. In this task, you will complete assembly of the front end wall.

NOTE

The front end wall includes a panel with the GFS logo on one side. This panel has a unique part number as indicated in the Bill of Materials on the End Wall page of the Design Drawings. Refer to the drawing when building the end wall, and install the branded panel at the designated location in the assembly. Ensure that the logo faces the booth’s exterior.

NOTE

Use 5/16-inch x 3/4-inch bolts and nuts except where noted.

NOTE

Tighten all bolts to finger-tight. You will be directed to plumb, tighten, and anchor the end wall later in the procedure.

Reference: During this step, you will need to refer to the Design Drawings pages for the frame and end wall:

- **For the frame:** Refer to the GP Single Frame page for details on frame assembly.

- **For the end wall:** Refer to the Overall Assembly page to determine what type of product door is specified for the front of the booth (either roll-up or non-roll-up). Then refer to the appropriate End Wall page for details:
 - **DT-RU:** Drive-Through Roll-Up end wall, for use with a roll-up door
 - **DT:** Drive-Through end wall, for use with a non-roll-up door

IMPORTANT

The images below provide *general* building instructions and design concepts. **Always refer to the appropriate page in the Design Drawings** for guidance on your *specific* booth.

1. Referring to the GP Single Frame page of the Design Drawings, build the upper portion of the single-frame assembly (vertical pieces, horizontal piece, and corner plates).

Then connect the vertical frame pieces of that sub-assembly to the corner plates extending up from the side-wall frames.

NOTE

Use 1/2-inch x 1-inch bolts and nuts to connect corner plates to frame pieces.

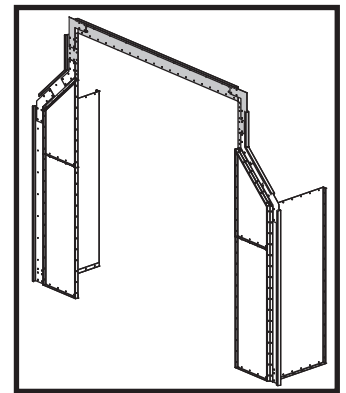
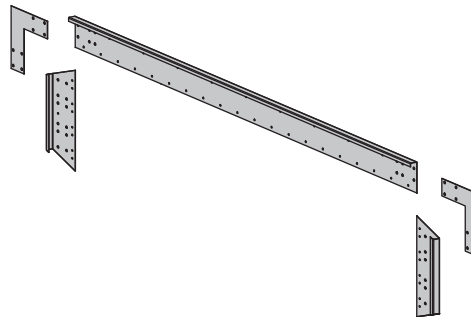

2. Referring to the appropriate End Wall page of the Design Drawings (either DT or DT-RU), install the remaining panels and tie angles required to complete the end wall.

NOTE

The left and right sides of the end wall are already present because they were installed during "Build the front corners of the booth" (page 29).

Install the door frame for the front product door

Prerequisites: The front end wall must be assembled as described in "Build the front end wall" (page 32).

Reference: Refer to the appropriate Product Door page and the Back View on the Overall Assembly page of the Design Drawings to determine what type of back wall is specified for this booth. Then perform the appropriate task:

- **For a roll-up door:** Perform "*If applicable:* Install the frame for a roll-up door" (page 34).
- **For a non-roll-up door:** Perform "*If applicable:* Install the frame for a non-roll-up door" (page 35).

If applicable: Install the frame for a roll-up door

Scope: This task applies only if the booth has a roll-up product door.

NOTE

When installing door frames, be aware of which end of the booth you're working at (front or rear) and make sure you install the correct type of door frame for that end, as specified on the Design Drawings.

Reference: Refer to the Roll Up Door Kit page of the Design Drawings.

IMPORTANT

Review all detail views and notes on the Design Drawings page. Some detail views and notes are specific to a particular booth type; be sure to use the directions that apply to the booth you are installing.

1. Install the flashing.

NOTE

Be sure to orient the flashing as specified for the particular type of booth you are installing.

NOTE

For greater efficiency, install the flashing when you build the chamber or end wall where this door frame will be installed. If the chamber or end wall is already assembled, you will have to remove some bolts in order to install the flashing.

2. Install the jambs and header.

NOTE

Refer to the Jamb Connection Detail on the Roll-Up Door Kit page of the Design Drawings.

3. Anchor the door jambs to the floor.

NOTE

For instructions on anchoring, refer to the "Roll Up Jamb to Slab Connection" view and related notes on the General Structural Notes page of the Design Drawings.

4. Anchor the end wall to the floor.

NOTE

For instructions on anchoring, refer to the "Panel to Slab Connection" view and related notes on the General Structural Notespage of the Design Drawings.

If applicable: Install the frame for a non-roll-up door

NOTE

This task applies only if the booth has a non-roll-up product door.

NOTE

When installing door frames, be aware of which end of the booth you're working at (front or rear) and make sure you install the correct type of door frame for that end, as specified on the Design Drawings.

Reference: Refer to the appropriate Product Door - Solid page of the Design Drawings.

1. Install the left and right door jamb assemblies.

NOTE

If extended jambs are used, field-drill and bolt the jambs to the booth structure or panels using 1/2-inch x 1-1/2-inch bolts and nuts.

NOTE

For greater efficiency, install the door jambs when you build the exhaust bridge chamber or end wall where this door frame will be installed. If the chamber or end wall is already assembled, you will have to remove some bolts in order to install the door jambs.

2. Connect the door header assembly to the left and right door jamb assemblies.

NOTE

Refer to the Jamb/Header Connections detail on the Product Door page of the Design Drawings.

NOTE

Use 5/16-inch x 1-inch bolts and nuts for jamb-to-header connections.

3. Confirm that the door frame is plumb, square, and level.

NOTE

An uneven floor can cause product doors to sag or bind. If necessary, place shims under door jambs to even the doors out. GFS does not provide shims for product doors.

4. Tighten all bolts in the door frame to snug-tight.

NOTE

Do not anchor the door jambs at this time. You will be directed to anchor the door jambs later in the procedure. (See "*If applicable: Install a non-roll-up door*" (page 51).)

Assemble the bays

NOTE

This booth can contain three or four bays. Each bay can be either 6 or 9 feet in depth. This booth has one personnel door in the rear-most bay.

NOTE

The bay configuration for your booth is specific to your site. Refer to the bay layout data you collected in "Collecting data from the Design Drawings" (page 16), or to the Plan View on the Overall Assembly page of the Design Drawings to determine the build sequence for your bays, the size of each bay, and if applicable, the door layout for a given bay.

NOTE

Build bays in order from the front to the back of the booth.

NOTE

Use 5/16-inch x 3/4-inch bolts and nuts for all panel-to-panel, tie angle-to-tie angle, and panel-to-tie angle connections.

NOTE

Use one 5/16-inch x 1/2-inch bolt and nut every six inches for all filter rack-to-filter rack connections and for all panel-to-filter rack connections.

Reference: Refer to the appropriate Bay Assembly of the Design Drawings.

Build the front bay

Prerequisites: The front corners, front end wall, and door frame for the front product door must be installed.

NOTE

You already assembled part of the front bay when you built the front corners of the booth. In this task, you will complete the rest of the front bay.

Reference: Refer to the appropriate Bay Assembly of the Design Drawings.

Reference: Refer to the GP Double Frame page of the Design Drawings.

IMPORTANT

The images below provide *general* building instructions and design concepts. **Always refer to the appropriate page in the Design Drawings** for guidance on your *specific* booth.

1. Complete the side walls.
2. Build the double-frame sub-assemblies for the sides.

NOTE

For double frames: Connect “like” parts together using 5/16-inch x 3/4-inch bolts and nuts inserted through the holes at the flanges (12-inches O.C.).

NOTE

Use 1/2-inch x 1-inch bolts and nuts to connect corner plates to frame pieces.

NOTE

Tighten bolts only to finger-tight

NOTE

The image below shows how to construct the double-frame sub-assembly for one side wall; also construct a mirror image for the opposite side wall.

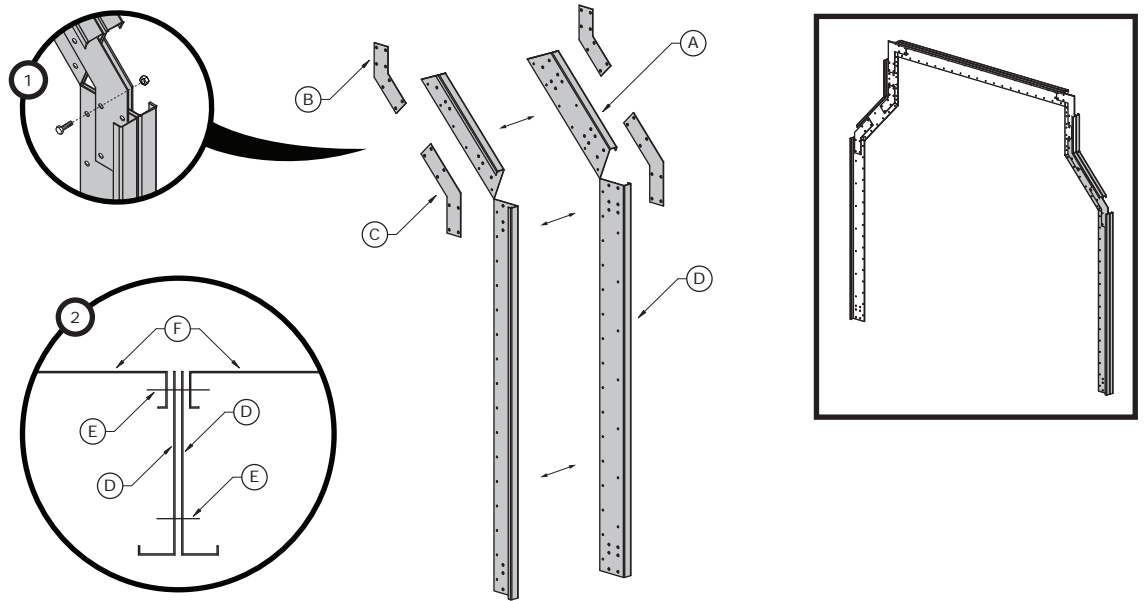

3. Connect the double-frame sub-assemblies to the side walls *temporarily*.

NOTE

Use 5/16-inch x 3/4-inch bolts and nuts for all frame-to-panel connections.

NOTE

You must remove these bolts when you connect the end wall, so use only a few bolts and tighten them only to finger-tight.

4. Install the panels that form the outer edges of the plenum floor.
5. Build the plenum roof on the floor.

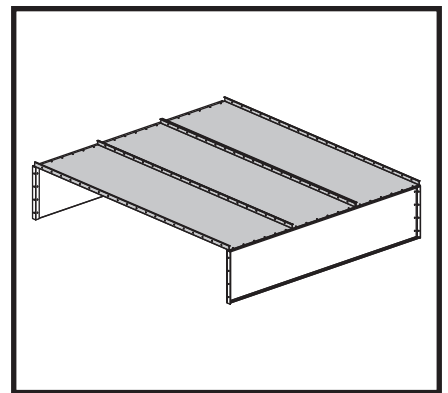
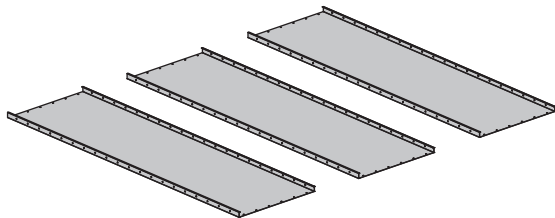

6. Connect the plenum sides to the assembled roof.

NOTE

Use a forklift to raise the assembled roof just high enough to install the side panels.

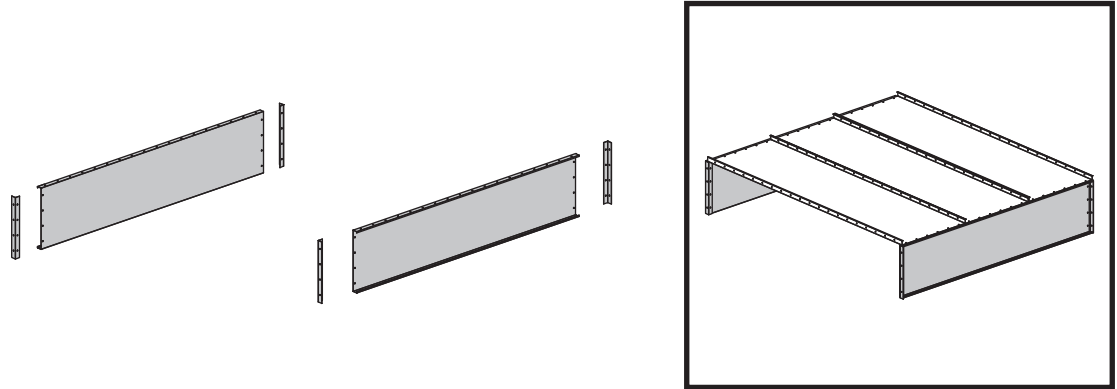

7. Use a forklift to lift the plenum sub-assembly (roof and sides) onto the top of the bay; then **hold it in place with the forklift** while you connect it to the side walls and to the single-frame assembly between the bay and the end wall.
8. **Continue holding the plenum in place with the forklift** while you install the vertical double-frame pieces on the sides of the plenum.

NOTE

Connect the vertical double-frame to the plenum's side panels and to the corner plates that extend up from the side-wall double-frame assemblies.

NOTE

Use 1/2-inch x 1-inch bolts and nuts to connect corner plates to frame pieces.

NOTE

Use 5/16-inch x 3/4-inch bolts and nuts for all frame-to-panel connections.

9. **Continue holding the plenum in place with the forklift** while you plumb and tighten the sections of the booth assembled so far:
 - a. Ensure that the front bay and front end wall are plumb, square, and level.

NOTE

For uneven floors, use the supplied shims to adjust the column height of the frame. You can use up to two shims per base pad for a maximum 1/4-inch adjustment. For more information, refer to the Base Detail view on the GP Double Frame page of the Design Drawings.

- b. Ensure that the door frame for the front product door is plumb, square, and level.

NOTE

An uneven floor can cause product doors to sag or bind. If necessary, place shims under door jambs to even the doors out. GFS does not provide shims for product doors.

- c. Working from front to back, tighten to snug-tight all bolts in the door frame, the front end wall, and the front bay (including the single-frame assembly between the front end wall and the front bay).
10. After tightening all the bolts to snug-tight, remove the forklift support from under the plenum roof.
11. Build the horizontal double-frame sub-assembly; then connect that sub-assembly to the plenum roof.

NOTE

The corner plates connect to the vertical frame on each side of the plenum. The horizontal frame piece connects to the plenum roof.

NOTE

Use 1/2-inch x 1-inch bolts and nuts to connect corner plates to frame pieces.

NOTE

Use 5/16-inch x 3/4-inch bolts and nuts for all frame-to-panel connections.

NOTE

As you complete this step, tighten all bolts to finger-tight initially. After you have installed all the bolts required for this step, tighten the bolts to snug-tight.

12. Install the filter racks in the plenum floor.

NOTE

Use one 5/16-inch x 1/2-inch bolt and nut every six inches for all filter rack-to-filter rack connections and for all panel-to-filter rack connections.

NOTE

As you complete this step, tighten all bolts to finger-tight initially. After you have installed all the bolts required for this step, tighten the bolts to snug-tight.

Build a center bay

Prerequisites: The front bay must be assembled as directed in “Build the front bay” (page 36).

NOTE

This bay connects to the double-frame assembly already installed on the end of the previous bay. When you connected that double frame assembly to the previous bay, you were directed to use only enough bolts to hold the double-frame assembly in position. During this step, you must remove those temporary bolts in order to connect this bay to that double-frame assembly.

NOTE

Use 5/16-inch x 3/4-inch bolts and nuts except where noted. Tighten all bolts onto to finger tight except where noted.

NOTE

A center bay does not contain any doors.

Reference: Use the Plan View on the Overall Assembly page of the Design Drawings to identify which size bay you are about to build. Then refer to the appropriate Bay Assembly page as you complete this step.

Reference: Refer to the GP Double Frame page for details on frame assembly.

IMPORTANT

The images below provide *general* building instructions and design concepts. **Always refer to the appropriate page in the Design Drawings** for guidance on your *specific* booth.

1. Build the side walls.
2. Build the double-frame sub-assemblies for the sides; then connect the double-frame sub-assemblies to the side walls.

NOTE

For instructions on building and connecting a double-frame sub-assembly, see “Build the front bay” (page 36).

3. Install the panels that form the outer edges of the plenum floor.
4. Build the plenum roof on the floor.

IMPORTANT

If the AMU ductwork connects into the top of this bay, replace the appropriate solid roof panel with the panel that has the cutout for the intake baffle. Refer to the AMU Kit page of the Design Drawings for details.

NOTE

To locate where ductwork for a top-entry AMU connects into the booth, refer to the main drawing on the Overall Assembly page and to the Side Elevation view on the Concept page of your Design Drawings.

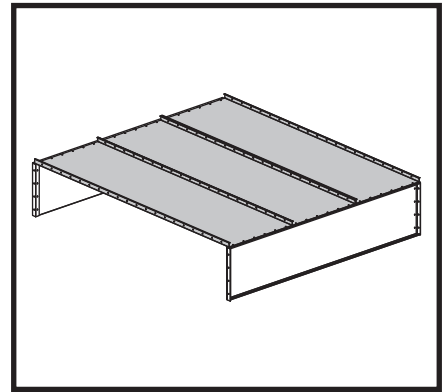
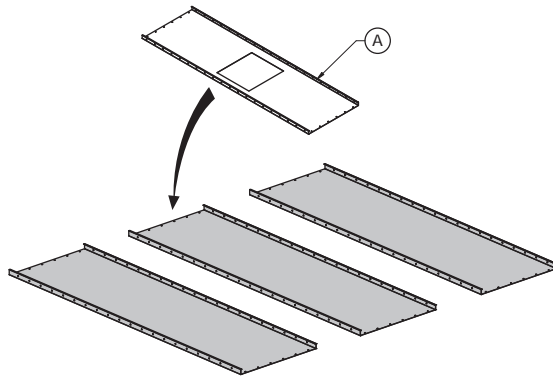

A: If applicable: Replace the appropriate solid plenum roof panel with the intake panel. This substitution applies only if this booth uses a top-entry AMU and only if the AMU ductwork connects into the top of this particular bay. Consult your Design Drawings to determine which panel should be replaced.

5. Connect the plenum sides to the assembled roof.

NOTE

Use a forklift to raise the assembled roof just high enough to install the side panels.

IMPORTANT

If the AMU ductwork connects into the side of this bay, do not install the corresponding side panel A in this step. Instead, leave it out so you can install the pieces that form the ductwork opening in the next step.

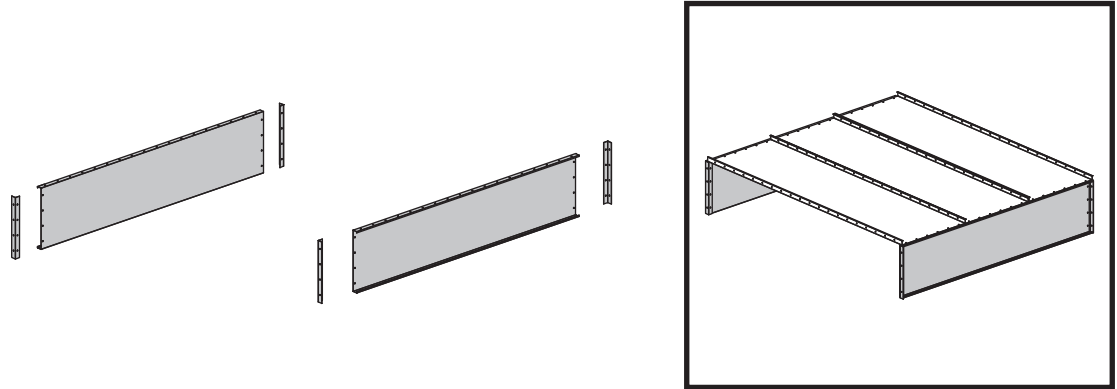

6. **For a vertical side-entry AMU:** If the AMU ductwork connects into the side of this bay, install the pieces that form the opening for the ductwork:
 - a. Referring to the AMU Kit page of the Design Drawings, install the panels fit on the left and right sides of the opening.
 - b. Place a section of duct lip along the top of the hip panel so that it fits between the two side panels you just installed; then place the tie angle from the Diffuser Assembly page on top of the duct lip. Connect both pieces (the tie angle and the duct lip) to the top of the hip panel.

NOTE

If you do not install the tie angle for the diffuser now, you will have to remove the bolts from the lower duct lip in order to install the tie angle later (when you install the diffuser assembly).

- c. Install the upper duct lip between the top edge of the two side panels.

NOTE

To locate where ductwork for a side-entry AMU connects into the booth, refer to the main drawing on the Overall Assembly page and to the Plan View on the Concept page of your Design Drawings.

7. Use a forklift to lift the plenum sub-assembly (roof and sides) onto the top of the bay; then **hold it in place with the forklift** while you connect it to the side walls and to the double-frame assembly between this bay and the previous bay.
8. **Continue holding the plenum in place with the forklift** while you install the vertical double-frame pieces on the sides of the plenum.

NOTE

Connect the vertical double-frame to the plenum's side panels and to the corner plates that extend up from the side-wall double-frame assemblies.

NOTE

Use 1/2-inch x 1-inch bolts and nuts to connect corner plates to frame pieces.

NOTE

Use 5/16-inch x 3/4-inch bolts and nuts for all frame-to-panel connections.

9. **Continue holding the plenum in place with the forklift** while you plumb and tighten the sections of the bay assembled so far:
 - a. Ensure that the bay is plumb, square, and level.

NOTE

For uneven floors, use the supplied shims to adjust the column height of the frame. You can use up to two shims per base pad for a maximum 1/4-inch adjustment. For more information, refer to the Base Detail view on the GP Double Frame page of the Design Drawings.

- b. Tighten all bolts in the bay to snug-tight.
10. After tightening all the bolts to snug-tight, remove the forklift support from under the plenum roof.
 11. Build the horizontal double-frame sub-assembly; then connect that sub-assembly to the plenum roof.

NOTE

The corner plates connect to the vertical frame on each side of the plenum. The horizontal frame piece connects to the plenum roof.

NOTE

Use 1/2-inch x 1-inch bolts and nuts to connect corner plates to frame pieces.

NOTE

Use 5/16-inch x 3/4-inch bolts and nuts for all frame-to-panel connections.

NOTE

As you complete this step, tighten all bolts to finger-tight initially. After you have installed all the bolts required for this step, tighten the bolts to snug-tight.

12. **For a roof-mounted, above-booth, or vertical top-entry AMU:** If the AMU ductwork connects into the top of this bay, install the intake baffle.

NOTE

Perform this step *only* if the AMU connects into this bay, and *only* if you replaced the appropriate solid roof panel with the intake panel in Step 4.

NOTE

To locate where ductwork for a top-entry AMU connects into the booth, refer to the main drawing on the Overall Assembly page and to the Side Elevation view on the Concept page of your Design Drawings.

NOTE

The legs of the intake baffle connect on either side of the panel. Field-drill and bolt using 5/16-inch x 3/4-inch bolts and nuts.

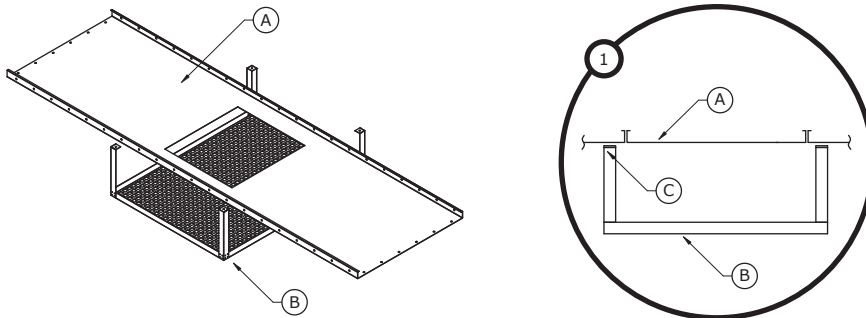

13. **For a vertical side-entry AMU:** If the AMU ductwork connects into the side of this bay, install the diffuser assembly:

- a. Bolt the lower front edge of the diffuser assembly to the diffuser tie angle using 5/16-inch x 3/4-inch bolts and nuts.

NOTE

You installed the diffuser tie angle with the duct lip in an earlier step.

- b. Attach the diffuser supports to the plenum ceiling using #14 Tek screws.

NOTE

For details, refer to the Diffuser Assembly page of the Design Drawings.

NOTICE

Be careful not to bend the tabs on the diffuser during installation.

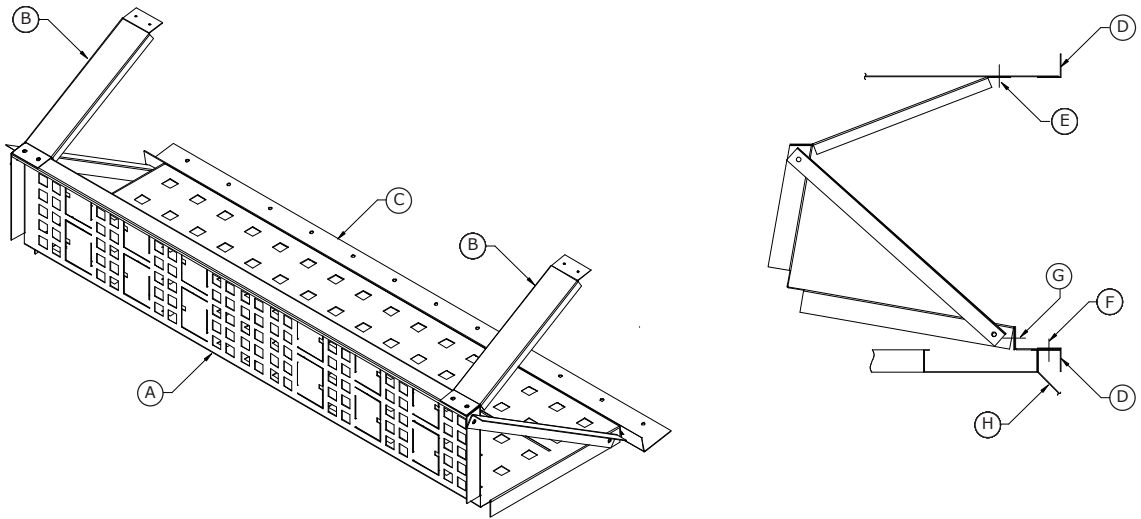

A: Diffuser assembly

B: Diffuser support

C: Diffuser tie angle

D: Duct lip

E: #14 Tek screws

F: 5/16-inch x 3/4-inch bolts and nuts (connecting duct lip and tie angle to hip panel; previously installed)

G: 5/16-inch x 3/4-inch bolts and nuts (connecting diffuser to tie angle)

H: Hip panel.

14. Install the filter racks in the plenum floor.

NOTE

If the AMU ductwork connects into the top or side of this bay, be sure to install the intake baffle (for top-entry) or diffuser (for side-entry) before completing this step. Otherwise, you will have to remove the filter racks in order to install the intake baffle or diffuser later in the procedure.

NOTE

Use one 5/16-inch x 1/2-inch bolt and nut every six inches for all filter rack-to-filter rack connections and for all panel-to-filter rack connections.

NOTE

As you complete this step, tighten all bolts to finger-tight initially. After you have installed all the bolts required for this step, tighten the bolts to snug-tight.

15. Working from front to back, build the next bay:

- **If the next bay is a center bay** (i.e., not one of the two end bays): Repeat this task.
- **If the next bay is the rear bay:** Follow the instructions in “Build the rear bay” (page 44).

NOTE

Refer to the Plan View on the Overall Assembly page of the Design Drawings to determine bay sequence.

Build the rear bay

Prerequisites: The center bays must be assembled as described in “Build a center bay” (page 39).

NOTE

This bay connects to the double-frame assembly already installed on the end of the previous bay. When you connected that double frame assembly to the previous bay, you were directed to use only enough bolts to hold the double-frame assembly in position. During this step, you must remove those temporary bolts in order to connect this bay to that double-frame assembly.

NOTE

Use 5/16-inch x 3/4-inch bolts and nuts except where noted. Tighten all bolts onto to finger tight except where noted.

Reference: Refer to the appropriate Bay Assembly page of the Design Drawings.

Reference: Refer to the GP Single Frame page of the Design Drawings.

IMPORTANT

The images below provide *general* building instructions and design concepts. **Always refer to the appropriate page in the Design Drawings** for guidance on your *specific* booth.

1. Build the side wall that has the door.

NOTE

A standard General Purpose booth contains one personnel door located in the rear-most bay. The door can be located on the bay’s left or right side wall. Use the Bay Assembly drawing as a guide, but adjust the location of the door framing as necessary for the particular bay you are building. (To determine the door position for a given bay, refer to the Plan View on the Overall Assembly page of the Design Drawings.)

NOTE

Do not hang the door or install any door hardware during this step.

NOTE

Use one 5/16-inch x 1/2-inch bolt and nut every six inches for all filter rack-to-filter rack connections and for all panel-to-filter rack connections.

NOTE

Tighten bolts only to finger-tight

2. Build the side wall that does not have a door.

NOTE

Use one 5/16-inch x 1/2-inch bolt and nut every six inches for all filter rack-to-filter rack connections and for all panel-to-filter rack connections.

NOTE

Tighten bolts only to finger-tight

3. Build the **single-frame** sub-assembly for each side wall.

NOTE

Use 1/2-inch x 1-inch bolts and nuts to connect corner plates to frame pieces.

NOTE

Tighten bolts only to finger-tight

NOTE

The image below shows how to construct the single-frame sub-assembly for one side wall; also construct a mirror image for the opposite side wall.

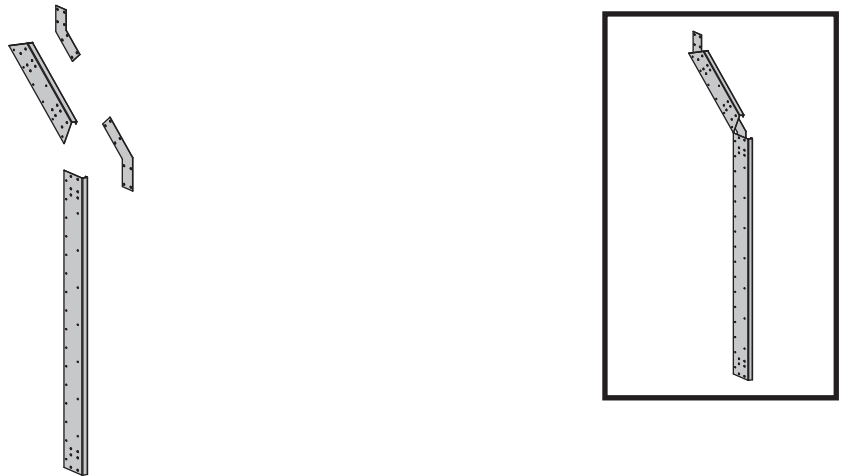

4. Connect the single-frame sub-assemblies to the side walls of the bay.

IMPORTANT

Orient the single-frame sub-assembly so that the flanged edges face the rear of the booth (i.e., away from the personnel door). Otherwise, the flange will block the personnel door from opening.

NOTE

Use 5/16-inch x 3/4-inch bolts and nuts for all frame-to-panel connections.

NOTE

You must remove these bolts when you connect the end wall, so use only a few bolts and tighten them only to finger-tight.

5. Install the panels that form the outer edges of the plenum floor.
6. Build the plenum roof on the floor.

IMPORTANT: If the AMU ductwork connects into the top of this bay, replace the appropriate solid roof panel with the panel that has the cutout for the intake baffle. Refer to the AMU Kit page of the Design Drawings for details.

NOTE

To locate where ductwork for a top-entry AMU connects into the booth, refer to the main drawing on the Overall Assembly page and to the Side Elevation view on the Concept page of your Design Drawings.

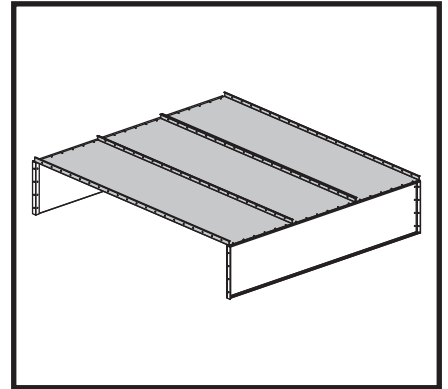
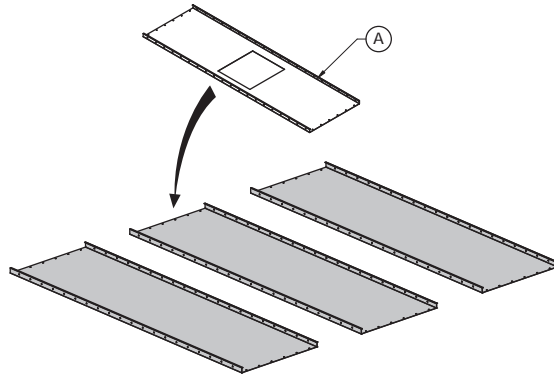

A: If applicable: Replace the appropriate solid plenum roof panel with the intake panel. This substitution applies only if this booth uses a top-entry AMU and only if the AMU ductwork connects into the top of this particular bay. Consult your Design Drawings to determine which panel should be replaced.

7. Connect the plenum sides to the assembled roof.

NOTE

Use a forklift to raise the assembled roof just high enough to install the side panels.

IMPORTANT

If the AMU ductwork connects into the side of this bay, do not install the corresponding side panel A in this step. Instead, leave it out so you can install the pieces that form the ductwork opening in the next step.

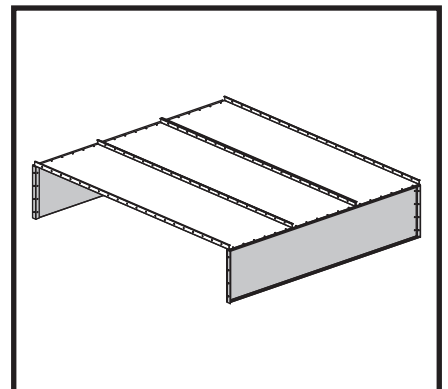
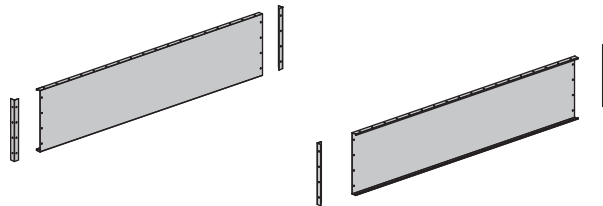

8. **For a vertical side-entry AMU:** If the AMU ductwork connects into the side of this bay, install the pieces that form the opening for the ductwork.
 - a. Referring to the AMU Kit page of the Design Drawings, install the panels fit on the left and right sides of the opening.

- b. Place a section of duct lip along the top of the hip panel so that it fits between the two side panels you just installed; then place the tie angle from the Diffuser Assembly page on top of the duct lip. Connect both pieces (the tie angle and the duct lip) to the top of the hip panel.

NOTE

If you do not install the tie angle for the diffuser now, you will have to remove the bolts from the lower duct lip in order to install the tie angle later (when you install the diffuser assembly).

- c. Install the upper duct lip between the top edge of the two side panels.

NOTE

To locate where ductwork for a side-entry AMU connects into the booth, refer to the main drawing on the Overall Assembly page and to the Plan View on the Concept page of your Design Drawings.

9. Use a forklift to lift the plenum sub-assembly (roof and sides) onto the top of the bay; then **hold it in place with the forklift** while you connect it to the side walls and to the double-frame assembly between this bay and the previous bay.
10. **Continue holding the plenum in place with the forklift** while you install the vertical single-frame pieces on the sides of the plenum.

NOTE

Connect the vertical single-frame to the plenum's side panels and to the corner plates that extend up from the side-wall single-frame assemblies.

NOTE

Use 1/2-inch x 1-inch bolts and nuts to connect corner plates to frame pieces.

NOTE

Use 5/16-inch x 3/4-inch bolts and nuts for all frame-to-panel connections.

11. **Continue holding the plenum in place with the forklift** while you plumb and tighten the sections of the bay assembled so far:
 - a. Ensure that the bay is plumb, square, and level.

NOTE

For uneven floors, use the supplied shims to adjust the column height of the frame. You can use up to two shims per base pad for a maximum 1/4-inch adjustment. For more information, refer to the Base Detail view on the GP Double Frame page of the Design Drawings.

- b. Tighten all bolts in the bay to snug-tight.
12. After tightening all the bolts to snug-tight, remove the forklift support from under the plenum roof.
13. Build the horizontal **single-frame** sub-assembly; then connect that sub-assembly to the plenum roof.

NOTE

The corner plates connect to the vertical frame on each side of the plenum. The horizontal frame piece connects to the plenum roof.

NOTE

Use 1/2-inch x 1-inch bolts and nuts to connect corner plates to frame pieces.

NOTE

Use 5/16-inch x 3/4-inch bolts and nuts for all frame-to-panel connections.

NOTE

As you complete this step, tighten all bolts to finger-tight initially. After you have installed all the bolts required for this step, tighten the bolts to snug-tight.

14. **For a roof-mounted, above-booth, or vertical top-entry AMU:** If the AMU ductwork connects into the top of this bay, install the intake baffle.

NOTE

Perform this step *only* if the AMU connects into this bay, and *only* if you replaced the appropriate solid roof panel with the intake panel.

NOTE

To locate where ductwork for a top-entry AMU connects into the booth, refer to the main drawing on the Overall Assembly page and to the Side Elevation view on the Concept page of your Design Drawings.

NOTE

The legs of the intake baffle connect on either side of the panel. Field-drill and bolt using 5/16-inch x 3/4-inch bolts and nuts.

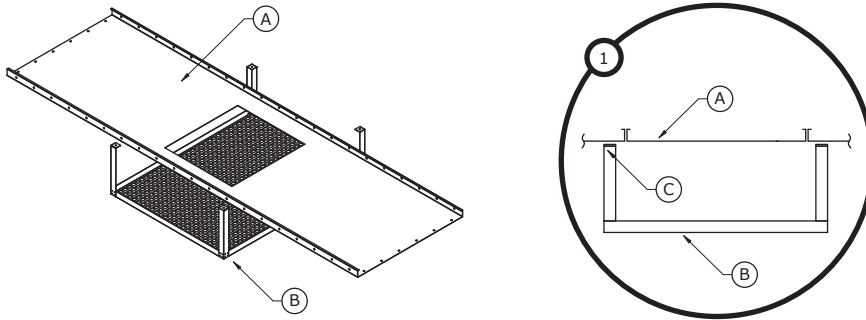

- A: Intake panel
- B: Intake baffle
- C: 5/16-inch x 3/4-inch bolts and nuts

15. **For a vertical side-entry AMU:** If the AMU ductwork connects into the side of this bay, install the diffuser assembly:
 - a. Bolt the lower front edge of the diffuser assembly to the diffuser tie angle using 5/16-inch x 3/4-inch bolts and nuts.

NOTE

You installed the diffuser tie angle with the duct lip in an earlier step.

- b. Attach the diffuser supports to the plenum ceiling using #14 Tek screws.

NOTE

For details, refer to the Diffuser Assembly page of the Design Drawings.

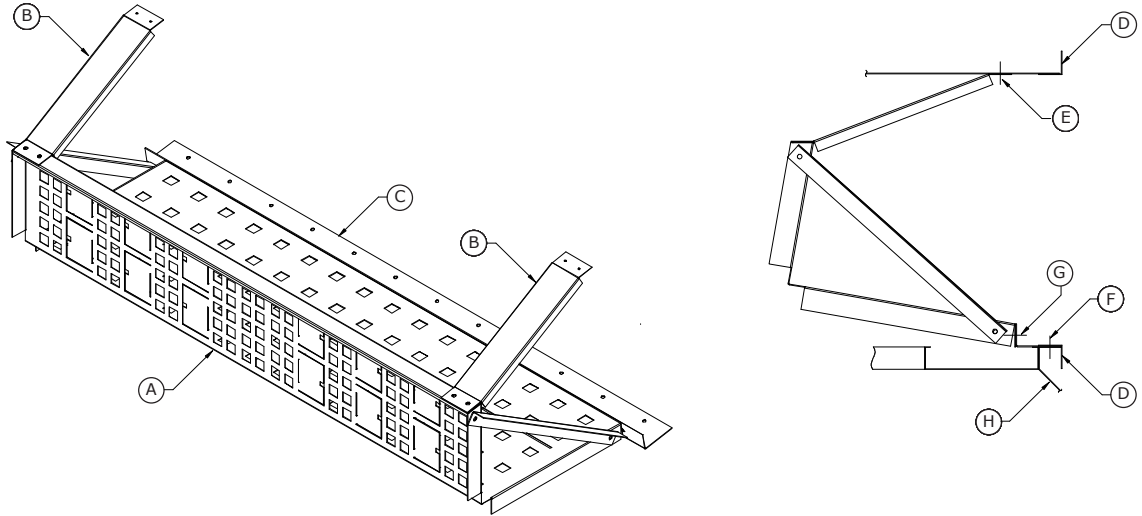

- A:** Diffuser assembly
- B:** Diffuser support
- C:** Diffuser tie angle
- D:** Duct lip
- E:** #14 Tek screws
- F:** 5/16-inch x 3/4-inch bolts and nuts (connecting duct lip and tie angle to hip panel; previously installed)
- G:** 5/16-inch x 3/4-inch bolts and nuts (connecting diffuser to tie angle)
- H:** Hip panel

16. Install the filter racks in the plenum floor.

NOTE

If the AMU ductwork connects into the top or side of this bay, be sure to install the intake baffle (for top-entry) or diffuser (for side-entry) before completing this step. Otherwise, you will have to remove the filter racks in order to install the intake baffle or diffuser later in the procedure.

NOTE

Use one 5/16-inch x 1/2-inch bolt and nut every six inches for all filter rack-to-filter rack connections and for all panel-to-filter rack connections.

NOTE

As you complete this step, tighten all bolts to finger-tight initially. After you have installed all the bolts required for this step, tighten the bolts to snug-tight.

17. When you have completed the rear bay, continue to “Build the rear end wall” (page 49) to build the rear end wall.

Build the rear end wall

Prerequisites: The rear bay must be completed as directed in “Build the rear bay” (page 44).

NOTE

Use 5/16-inch x 3/4-inch bolts and nuts for all panel and tie angle connections.

Reference: Refer to the Back View on the Overall Assembly page of the Design Drawings to determine which type of end wall is required at the rear of the booth. Then refer to the appropriate End Wall page for details:

- **SB:** Solid Back end wall
 - **DT:** Drive-Through end wall, for use with a non-roll-up product door
 - **DT-RU:** Drive-Through Roll-Up end wall, for use with a roll-up product door
1. Install panels and tie angles required for the rear end wall.
 2. Ensure that the completed end wall is plumb, square, and level.
 3. Tighten all bolts in the end wall to snug-tight.

***If applicable:* Install the door frame for the rear product door**

Prerequisites: The rear end wall must be installed as described in “Build the rear end wall” (page 49).

NOTE

This task applies only if this booth is a drive-through booth (i.e., a booth with product doors at both the front and rear). If this booth does not have a product door at the rear, skip this task and continue to the next section.

1. Refer to the Back View on the Overall Assembly page of the Design Drawings to determine which type of door is specified for the rear of the booth (either roll-up or non-roll-up).
2. Install the appropriate door frame for the specified door type:
 - **For a roll-up door:** Perform “*If applicable:* Install the frame for a roll-up door” (page 34).
 - **For a non-roll-up door:** Perform “*If applicable:* Install the frame for a non-roll-up door” (page 35).

Anchor the booth

Prerequisites:

- All bays must be assembled as described in “Assemble the bays” (page 35).
- If the booth has a solid end wall at the rear of the booth, that end wall must be assembled as described in “Build the rear end wall.” (page 49)

Reference: For instructions on anchoring, refer to the “Panel to Slab Connection” view and related notes on the General Structural Notes page of the Design Drawings document.

1. Make sure that the following sections of the booth are plumb, square, and level:
 - Each bay and frame assembly
 - *If applicable:* Solid-back rear end wall

NOTE

For uneven floors, use the supplied shims to adjust the column height of the frame. You can use up to two shims per base pad for a maximum 1/4 inch adjustment. For more information, refer to the Base Detail view on the GP Double Frame page of the Design Drawings.

2. Double-check that all bolts have been installed and are tightened to snug-tight.
3. Anchor each bay and each frame assembly.

4. *If applicable:* Anchor the solid-back rear end wall.

NOTE

This step applies only if this booth has a solid-back end wall at the rear of the booth. If this booth has a drive-through end wall at the rear (to accommodate a product door), skip this step.

Install product doors

Prerequisites: The appropriate door frame must be installed at the front of the booth. If this booth is a drive-through booth, the appropriate door frame must be installed at the back of the booth.

NOTE

Refer to the Concept Drawing and Overall Assembly pages of the Design Drawings to determine:

- Which type of product door is required on the front of the booth.
- Whether the booth also has a product door at the back of the booth and if so, which type.

Then complete the appropriate task for each specified door:

- **For a roll-up door:** Follow the instructions in “*If applicable:* Install a roll-up door” (page 51).
- **For a non-roll-up door:** Follow the instructions in “*If applicable:* Install a non-roll-up door” (page 51).

***If applicable:* Install a roll-up door**

Scope: This task applies only if the booth has a roll-up product door.

Prerequisites: The roll-up door frame must be installed.

Reference: Refer to the Roll Up Door Kit page of the Design Drawings.

Instruct the customer to contact the door manufacturer for professional installation.

NOTE

You will be directed to perform or coordinate additional tasks related to a roll-up door later in the procedure.

***If applicable:* Install a non-roll-up door**

Scope: This task applies only if the booth has a non-roll-up product door.

Prerequisites: The non-roll-up door frame must be installed.

Reference: Refer to the appropriate Product Door page of the Design Drawings.

1. Install the hinges and hang the product door as directed on the appropriate Product Door page.

NOTE

Use 5/16-inch x 3/4-inch bolts and nuts for hinge connections.

NOTE

Refer to the Door Hinge Detail view on the appropriate door Product Door page.

2. Align and square the doors.

NOTE

Check the gaps between hinged connections and ensure that they meet the specifications on the appropriate Product Door page.

CAUTION

Proper door alignment is critical to the operation of the booth. Ensure that there is equal space around the doors. Move the bottom of the door jamb to the left or right or in and out until the doors are sealed and plumb.

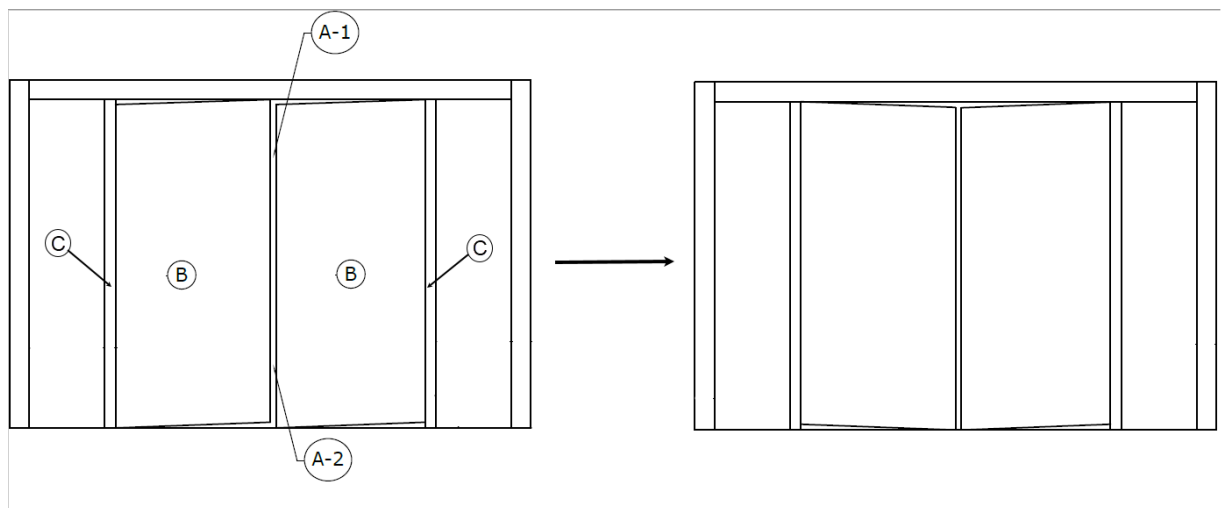

A: Gap between doors: The gap between the doors at the top (A-1) must be equal to the gap between the doors at the bottom (A-2)

B: Door slab

C: Door jamb

3. Once the doors have been squared and gaps are established, tighten the bolts to snug-tight and install Tek screws to lock them into place.
4. Anchor the door jambs to the floor.

NOTE

For instructions on anchoring, refer to the “Jamb to Slab Connection” view and related notes on the General Structural Notes page of the Design Drawings.

5. Anchor the end wall to the floor.

NOTE

For instructions on anchoring, refer to the "Panel to Slab Connection" view and related notes on the General Structural Notes page of the Design Drawings.

6. Install the door handles.

NOTE

Position the handles as shown on the Product Door page of the Design Drawings.

7. Install the Brixon safety latches.

NOTE

Refer to the Brixon Latch/Pad Assembly Detail view on the appropriate Product Door page of the Design Drawings. Also refer to the Brixon Template and to the manufacturer's instructions included with the Brixon hardware.

8. Install the door seals:
 - a. Affix P-seal gasket along the left and right door jambs; cut to length.
 - b. Affix P-seal gasket along the door stop; cut to length.
 - c. Affix the large D-seal gasket along the header; cut to length.

NOTE

Refer to the appropriate Product Door page of the Design Drawings document for seal locations.

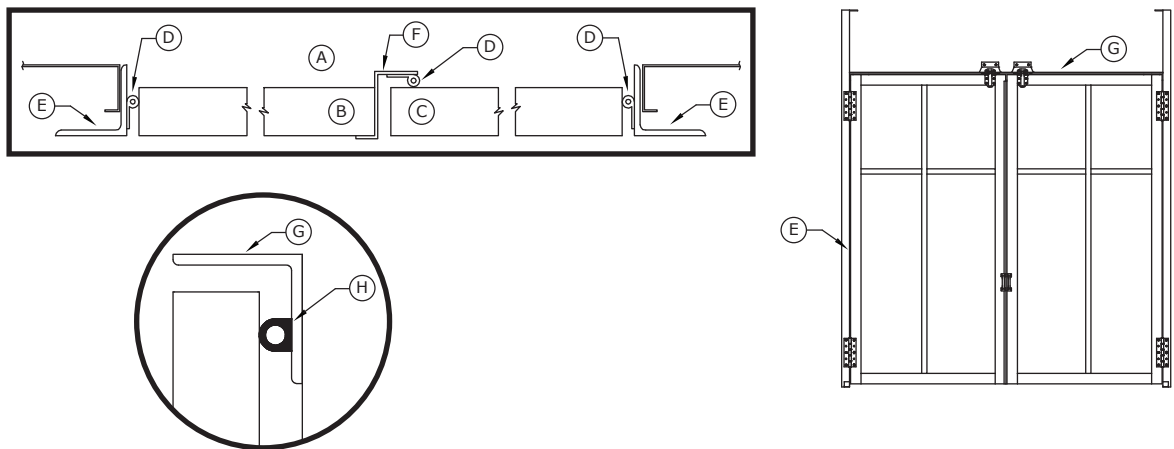

- A: Booth interior
- B: Left door
- C: Right door
- D: P-seal gasket
- E: Door jamb
- F: Door stop
- G: Door header
- H: Large D-seal gasket

9. Remove the pre-installed door sweep; level it with the floor and cut accordingly; then reattach it to the door.

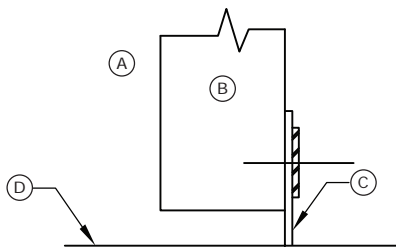

- A: Booth interior
- B: Product door
- C: Door sweep (installed at GFS)
- D: Finished floor

10. Place plugs (GFS part number 1014081) in all large open holes.

Install personnel doors

Prerequisites:

- The booth assembly must be complete, and all sections of the booth must be snug-tightened and anchored to the floor.
- The door jambs and headers for the personnel doors should be already installed in the side walls of the appropriate bay(s).

Reference: Refer to the Installation Instructions page for the personnel door (provided in the personnel door kit inside the "Miscellaneous" box).

IMPORTANT

The images below provide *general* building instructions and design concepts. **Always refer to the appropriate page in the Design Drawings** for guidance on your *specific* booth.

Mount the door

1. Confirm that the door frame is plumb, square, and level.
2. Use 5/16-inch x 3/4-inch bolts to mount the hinges to the personnel door.

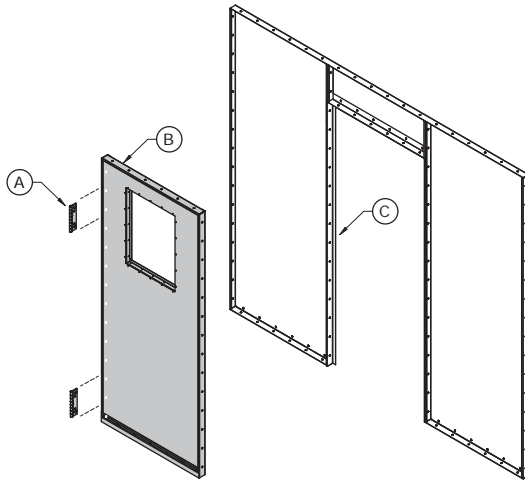

A: Hinge
B: Personnel door (with or without window)
C: Door jamb

3. Use 5/16-inch x 3/4-inch bolts and nuts to mount the hinges to the door jamb.

Attach the handles

Reference: Refer to the Installation Instructions page for the personnel door (provided in the personnel door kit inside the "Miscellaneous" box).

Use Tek screws to fasten a door handle to each side of the door.

NOTE

Follow the positioning guidelines in the accompanying diagram.

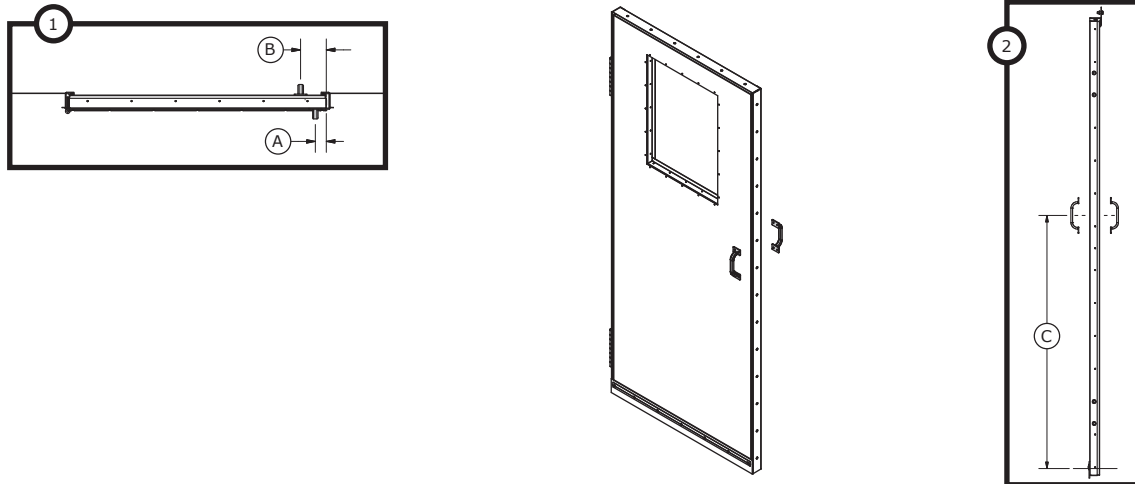

- A: Horizontal placement, outer handle: 1-1/2 inches from door edge*
B: Horizontal placement, inner handle: 3-1/2 inches from door edge
C: Vertical placement (both handles): 4 feet 0 inches from bottom of door to center of handle

Install the Brixon safety latch

Reference: Refer to the supplied Brixon Template. Also refer to the manufacturer's instructions included with the Brixon hardware. The template and hardware ship in the "Miscellaneous" box.

NOTE

For optimum interoperability, do not exceed a 1/4 inch between the body and the strike.

1. Use the Brixon Template to establish proper hole locations for Brixon-to-door and latch-to-jamb.
2. Drill two 3/8-inch holes through the door.

3. Mount the Brixon to the door using 5/16-inch x 2-1/2-inch bolts, nuts, and washers, with the bolt head to the inside of the door.

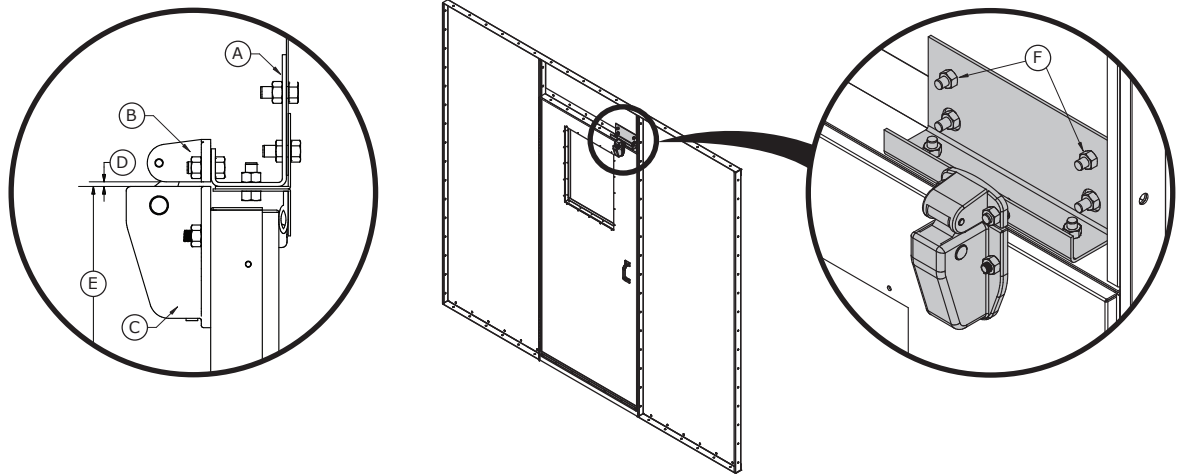

- A: Brixon mounting bracket
- B: Brixon strike
- C: Brixon body
- D: 1/8 inch
- E: 6 feet 10-3/16 inches from bottom of door
- F: Field-drill and bolt

4. Mount the latch to the bracket at the top of the door using 5/16-inch x 1-1/4-inch bolts, nuts, and washers.
5. Adjust the Brixon tension as necessary to ensure proper operation.

Install door seals

NOTE

Refer to the following diagram while completing this task.

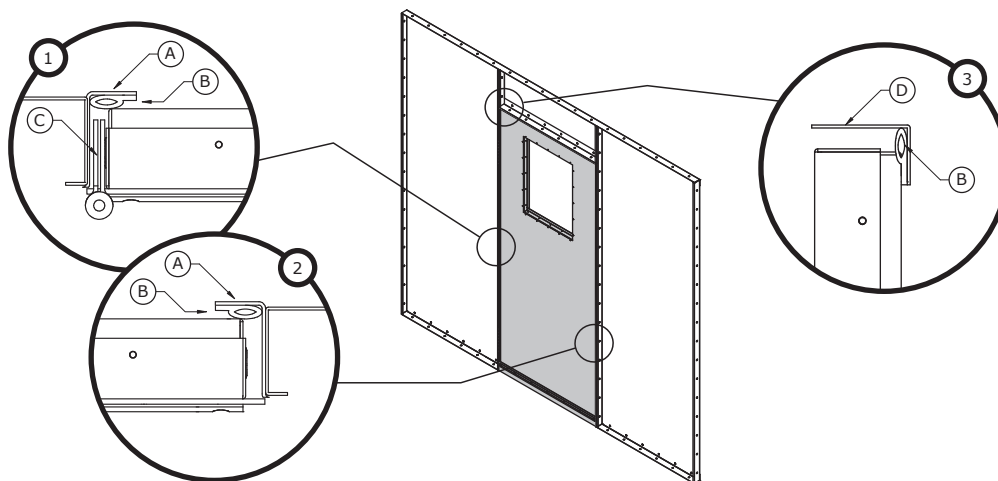

- A: Door jamb
- B: P-seal
- C: Hinge
- D: Door header

1. Affix P-seal gasket along the left and right door jambs; cut to length.
2. Affix P-seal gasket along the header; cut to length.

Install the exhaust fan(s)

Prerequisites: The fan panels must be attached and sealed to the fan openings on the pit, as directed on the Pit Assembly page of the Design Drawings. Attaching and sealing the fan panels is the customer's responsibility.

NOTE

Use 5/16-inch x 1-1/2-inch bolts to connect the exhaust fan to the fan panel.

NOTE

The direction of the fan blade rotation and the direction of the airflow are indicated on the outside of the exhaust fan housing.

1. Apply caulk around the opening of the fan panel.
2. Place the exhaust fan on a forklift, orienting the fan so that the fan motor will be facing the appropriate side of the booth when the fan is removed from the forklift.

NOTE

Refer to the Plan View on the Concept page of the Design Drawings to see how the fan motor should be oriented relative to the booth.

3. Lift the fan to the top of the exhaust chamber and place it onto the fan panel, orienting the fan so that:
 - The arrows on the airflow label point the correct direction.
 - The holes in the fan's lower flange align with the holes in the fan panel.

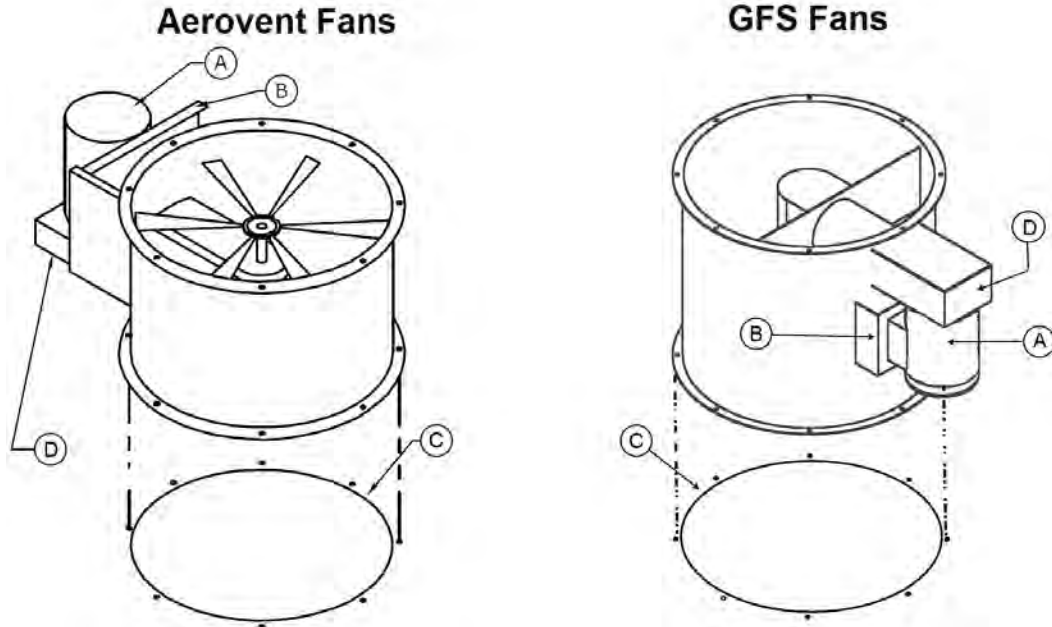

- A: Motor
- B: Motor plate
- C: Caulk location
- D: Belt guard

4. Bolt the fan to the fan panel using 5/16-inch x 1-1/2-inch bolts.

NOTE

Tighten the bolts to finger-tight until they are all installed; then tighten them to snug-tight.

5. Caulk the outside of the joint between the fan and the fan panel.

Assemble the exhaust stack(s)

Prerequisites: The exhaust fan(s) must be installed as directed in “Install the exhaust fan(s)” (page 57).

NOTE

Perform the applicable tasks in this section for each exhaust fan.

***If applicable:* Install spiral duct with Automatic Roof Ventilator (ARV)**

NOTE

This task applies only if the site is using spiral duct in their exhaust stack. If the site is using plain duct instead of spiral duct, perform “*If applicable:* Install plain duct with Automatic Roof Ventilator (ARV)” (page 60) instead of this task.

NOTE

For flange-to-flange connections, use:

- (8) 5/16-inch x 1-inch bolts
- (16) 5/16-inch flat washers
- (8) 5/16-inch lock washers
- (8) 5/16-inch nuts

NOTE

Refer to the diagram below while completing this task.

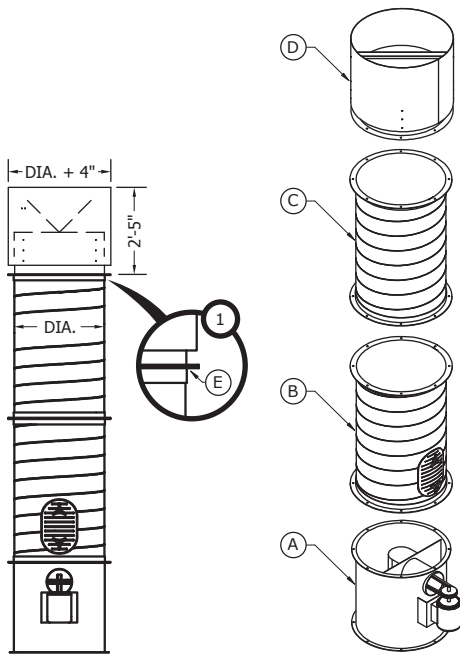

- A:** Exhaust fan
- B:** Spiral duct with clean-out door
- C:** Spiral duct (no door)
- D:** ARV
- E:** Flange-to-flange connection between ARV and duct

1. Install the spiral duct with clean-out door:
 - a. Apply caulk to the upper flange of the exhaust fan.
 - b. Orient the spiral duct with clean-out door so that the door is toward the bottom.
 - c. Connect the spiral duct with clean-out door to the exhaust fan flange-to-flange using the specified hardware.
2. Install the next section of spiral duct:
 - a. Apply caulk to the top flange of the previous duct section.
 - b. Connect the next section of spiral duct (without door) to the previous duct section flange-to-flange using the specified hardware.
3. Repeat the previous step for each additional section of duct in the exhaust stack.

When you have connected all the ductwork required for the exhaust stack, continue to the next step.

4. Install the ARV:
 - a. Apply caulk to the top flange of the top-most duct section.
 - b. Connect the ARV to the top-most duct section flange-to-flange using the specified hardware.
5. Working down from the ARV to the exhaust fan, caulk the outside of all connections in the exhaust stack.

NOTE

If the exhaust stack includes a roof flange and collar, be sure to caulk the joint between the collar and the duct.

If applicable: Install plain duct with Automatic Roof Ventilator (ARV)

Scope: This task applies only if the site is using plain duct in their exhaust stack. If the site is using spiral duct instead of plain duct, see “*If applicable: Install spiral duct with Automatic Roof Ventilator (ARV)*” (page 58).

NOTE

Use #10 self-tapping screws for duct-to-duct connections.

NOTE

Refer to the diagram below while completing this task.

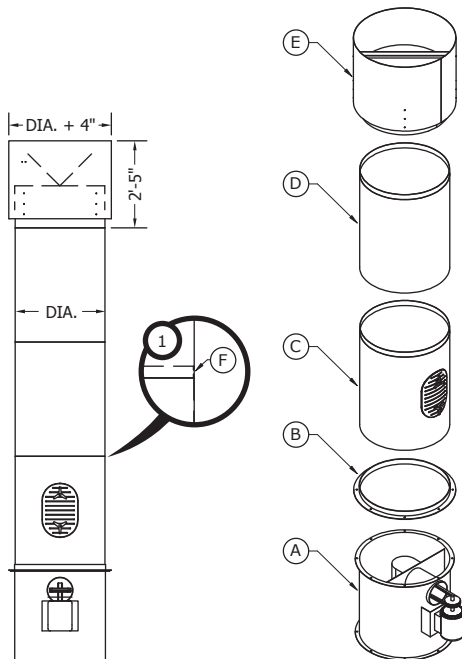

- A: Exhaust fan
- B: Fan ring (flange down; duct lip up)
- C: Plain duct with clean-out door
- D: Plain duct (no door)
- E: ARV
- F: Use #10 self-tapping screws for duct-to-duct connections; caulk outside of all connections

1. Connect the ring to the flange on top of the exhaust fan using the following hardware:
 - (8) 5/16-inch x 1-inch bolts
 - (16) 5/16-inch flat washers
 - (8) 5/16-inch lock washers
 - (8) 5/16-inch nuts
2. Connect the plain duct with clean-out door to the ring.

NOTE

Slip the bottom of the plain duct with clean-out door into the ring; then Tek-screw the duct from the outside in.

3. Connect a section of plain duct (without clean-out door) to the previous duct section.

NOTE

Slip the bottom of the plain duct into the top of the previous section; then Tek-screw the duct from the outside in.

4. Repeat the previous step for each additional piece of duct in the exhaust stack.

When you have connected all the ductwork required for the exhaust stack, continue to the next step.

5. Slip the bottom of the ARV into the top-most duct section; then Tek-screw the ARV from the outside in.
6. Working down from the ARV to the exhaust fan, caulk the outside of all connections in the exhaust stack.

NOTE

If the exhaust stack includes a roof flange and collar, be sure to caulk the joint between the collar and the duct.

If applicable: Install the guy-wire kit

Prerequisites: The ductwork and ARV must be installed as described in “*If applicable: Install spiral duct with Automatic Roof Ventilator (ARV)*” (page 58) or “*If applicable: Install plain duct with Automatic Roof Ventilator (ARV)*” (page 60).

NOTE

Install the guy-wire kit per the instructions below. It is the responsibility of the customer or their agent (for example, a roofer or building contractor) to supply and install the cable tie-off points on the building roof (plate with ring). The diagram below is provided for reference only.

NOTE

Use #10 Tek screws to attach duct strap to exhaust duct; caulk to seal.

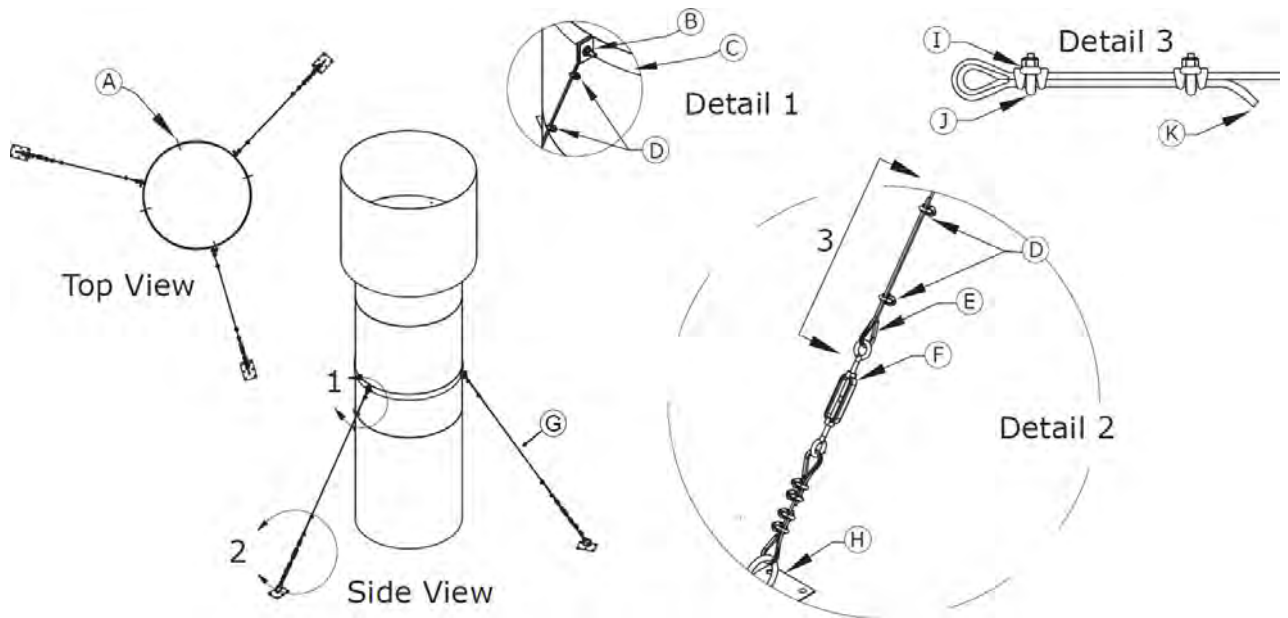

- A: #10 Tek screw
- B: For each connection, use one cable thimble; one 5/16-inch x 1-1/2-inch bolt; two 5/16-inch flat washers; one 5/16-inch lock washer; and one 5/16-inch nut.
- C: Duct strap
- D: Cable clamps (2)
- E: Thimble
- F: Turnbuckle
- G: Cable; thimbles (2); cable clamps (4)
- H: Plate with ring
- I: Grip base
- J: U-bolt (must have U-bolt over dead end of cable)
- K: Dead end

If applicable: Install an above-booth AMU

NOTE

This task applies *only* if this booth uses a horizontal AMU mounted on a stand that fits over the booth. If this booth uses a different AMU configuration, skip this task and all its sub-tasks.

Above-booth AMU: Install the AMU discharge duct

Prerequisites: The intake panel and intake baffle must already be installed in the plenum roof of the appropriate bay. The customer (or customer's agent) must have already completed the roof penetration.

NOTE

The AMU discharge duct goes between an intake opening at the booth and the discharge opening on the AMU.

Construct the AMU discharge duct as directed on the AMU Kit page of the Design Drawings and connect it to the ceiling panel above the intake baffle.

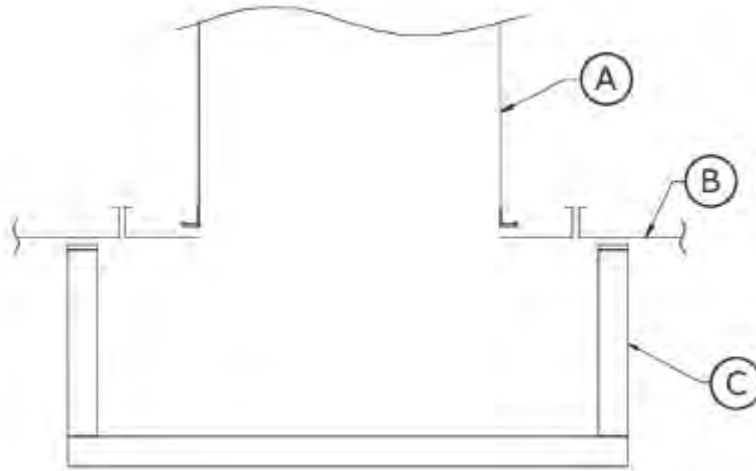

- A: AMU discharge duct
- B: Booth ceiling panel
- C: Intake baffle

Above-booth AMU: Assemble the AMU stand

Reference: Refer to the AMU Stand page of the Design Drawings.

1. Build the AMU stand as directed on the AMU Stand page of the Design Drawings.

NOTE

To determine the location of the stand relative to the booth, refer to the AMU Stand Placement Detail view on the AMU Kit page of the Design Drawings.

2. Anchor the AMU stand to the floor or pad.

NOTE

Anchoring the AMU stand is the responsibility of the customer or their agent.

NOTE

For instructions on anchoring, refer to the “AMU Stand to Slab Connection” view and related notes on the General Structural Notes page of the Design Drawings.

Above-booth AMU: Install the AMU unit

Prerequisites: The AMU stand must be assembled and anchored as described in “Above-booth AMU: Assemble the AMU stand” (page 63).

NOTE

Refer to the manufacturer’s supplied documentation for details about AMU installation, operation, and maintenance. The manufacturer’s documentation ships inside the AMU control panel.

Reference: Refer to the AMU Kit page of the Design Drawings.

1. Use a forklift to place the AMU onto the AMU stand.

NOTE

To determine the weight of the AMU, refer to the “AMU Specifications” table on the Concept page of the Design Drawings.

NOTE

The AMU is marked with arrows on each side that indicate the airflow direction.

2. Secure the AMU as directed on the AMU Kit page of the Design Drawings.

NOTE

Use #12 Tek screws.

3. Install the supplied filter section on the inlet end of the AMU.

NOTE

The filter section ships with the AMU and contains pre-installed filters. Refer to the manufacturer's documentation for instructions on installing the filter section.

Above-booth AMU: Install the AMU intake duct and hood

Prerequisites: The AMU unit must be installed as described in “*Above-booth AMU: Install the AMU unit*” (page 63).

NOTE

This task applies only when AMU ductwork was included as part of the booth order.

NOTE

Refer to the DuctMate manual for instructions about installing DuctMate components. Use #10 Tek screws at 6-inches O.C. for all non-DuctMate to DuctMate connections.

Reference: Refer to the AMU Kit - With Ductwork page of the Design Drawings.

1. Starting from the intake opening of the AMU unit: Install the AMU intake duct as shown on the AMU Kit page of the Design Drawings.

NOTE

The AMU intake duct goes from the intake opening on the AMU to the intake hood.

2. Connect the intake hood to the intake duct.

If applicable: Install a roof-mounted AMU

NOTE

This task applies *only* if this booth uses a horizontal AMU mounted on the roof of the building. If this booth uses a different AMU configuration, skip this task and all its sub-tasks.

Roof-mounted AMU: Install the AMU discharge duct

Prerequisites:

- The intake baffle must be installed in the plenum roof of the appropriate bay.

- The roofer or other customer agent must cut the hole in the roof for the AMU ductwork and install the AMU curb on the roof.

NOTE

This task applies only when AMU ductwork was included as part of the booth order.

NOTE

The AMU discharge duct goes between an intake opening at the booth and the discharge opening on the AMU unit.

NOTE

Apply caulk (supplied butyl tape) between flanges as you assemble the ductwork.

NOTE

Refer to the DuctMate manual for instructions about installing DuctMate components. Use #10 Tek screws at 6-inches O.C. for all non-DuctMate to DuctMate connections.

Reference: Refer to the AMU Kit page of the Design Drawings.

1. Build the discharge duct assembly.
2. Use Tek screws to connect it to the intake panel.

Roof-mounted AMU: Install the AMU unit

NOTE

Refer to the manufacturer's supplied documentation for details about AMU installation, operation, and maintenance. The manufacturer's documentation ships inside the AMU control panel.

NOTE

For a roof-mounted AMU, the intake hood is part of the AMU. Filters are pre-installed in the hood.

Reference: Within the Design Drawings, see the AMU Kit page and the Side Elevation view on the Concept Drawing page.

1. Use an appropriate lifting device (such as a crane) to lift the AMU onto the roof of the building and place it on the curb.

NOTE

To determine the weight of the AMU, refer to the "AMU Specifications" table on the Concept page of the Design Drawings.

NOTE

The AMU is marked with arrows on each side that indicate the airflow direction.

2. *Optional:* Use a few Tek screws to connect the curb to the AMU.

If applicable: Install a vertical AMU

NOTE

This task applies *only* if this booth uses a vertical AMU mounted on a stand that is located beside the unit (indoors) or at ground level (outdoors). If this booth uses a different AMU configuration, skip this task and all its sub-tasks.

Vertical AMU: Assemble the AMU stand

Reference: Refer to the AMU Stand page of the Design Drawings.

1. **Outdoor AMU only:** Build the AMU stand as directed on the AMU Stand page of the Design Drawings.

NOTE

This step applies only to stands that will be located outdoors. Indoor stands are shipped pre-assembled.

2. Place the assembled AMU stand in its designated location.

NOTE

To determine the location of the stand relative to the booth, refer to the AMU Stand Placement Detail view on the AMU Kit page of the Design Drawings.

3. Anchor the AMU stand to the floor or pad.

NOTE

Anchoring the AMU stand is the responsibility of the customer or their agent.

NOTE

For instructions on anchoring, refer to the “AMU Stand to Slab Connection” view and related notes on the General Structural Notes page of the Design Drawings.

Vertical AMU: Install the AMU unit

Prerequisites: The AMU stand must be assembled and anchored as described in “*Vertical AMU: Assemble the AMU stand*” (page 66).

NOTE

Refer to the manufacturer’s supplied documentation for details about AMU installation, operation, and maintenance. The manufacturer’s documentation ships inside the AMU control panel.

Reference: Refer to the AMU Kit page of the Design Drawings.

1. Drop the supplied filter section into the stand.

NOTE

The filter section ships with the AMU and contains pre-installed filters. Refer to the manufacturer's documentation for instructions on installing the filter section.

NOTE

See the Stand/AMU Section view on the AMU Kit page of the Design Drawings.

2. Use a forklift to place the AMU onto the AMU stand.

NOTE

To determine the weight of the AMU, refer to the “AMU Specifications” table on the Concept page of the Design Drawings.

NOTE

The AMU is marked with arrows on each side that indicate the airflow direction.

3. Secure the AMU as directed on the AMU Kit page of the Design Drawings.

NOTE

Use #12 Tek screws.

Vertical AMU: Install the AMU ductwork

Prerequisites:

- The AMU unit must be installed as described in “Vertical AMU: Install the AMU unit” (page 66).
- If the AMU is located outdoors, the customer must have the proper wall opening in their building.

NOTE

A vertical AMU used with this type of booth may connect into the booth from the top or from the side. Refer to your Design Drawings to determine which entry method is specified.

NOTE

This task applies only when AMU ductwork was included as part of the booth order.

NOTE

Apply caulk (supplied butyl tape) between flanges as you assemble the ductwork.

NOTE

Refer to the DuctMate manual for instructions about installing DuctMate components. Use #10 Tek screws at 6-inches O.C. for all non-DuctMate to DuctMate connections.

1. Install the AMU discharge duct as directed on the AMU Kit page of the Design Drawings.

NOTE

The AMU discharge duct goes between an intake opening at the booth and the discharge opening on the AMU unit.

2. **Indoor AMU only:** Assemble the intake duct box and connect it to the side of the AMU unit.

NOTE

For details, refer to the Intake Duct Box Assembly page of the Design Drawings.

3. **Indoor AMU only:** Starting from the top of the intake duct box, install the AMU intake duct as directed on the AMU Kit page of the Design Drawings.

NOTE

The AMU intake duct goes from the intake opening on the AMU unit to the intake hood.

4. **Indoor AMU only:** Connect the AMU hood to the top of the intake duct.

Install the lights

Prerequisites: The booth must be assembled.

NOTE

This task covers only the mechanical installation of the lighting fixtures; wiring should be performed by a qualified electrician as specified in “Perform electrical hookup” (page 82).

Install cage nuts in the light fixtures

NOTE

It is usually more efficient to install the cage nuts in all the light fixtures at one time (before you begin installing the lights).

NOTE

The light fixture box requires eight cage nuts.

1. Open the boxes containing the light fixture(s) and remove the hardware kit and the manufacturer’s instructions.
2. For each square hole on the light fixture box: Insert a cage nut into the hole and snap into position.

NOTE

Some force is required to snap in the nut.

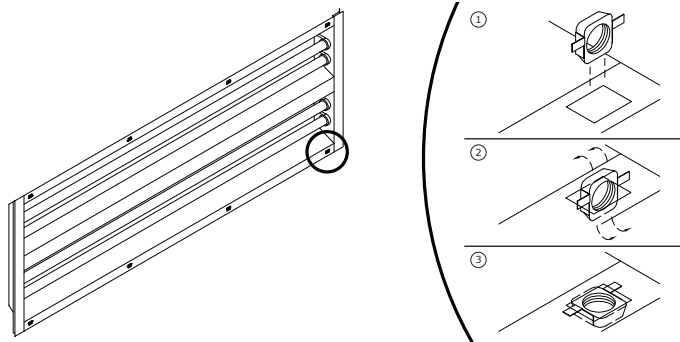

3. Confirm that each cage nut can slide within its hole.

NOTE

The cage nut must be able to slide to ensure that it can align with the cover bolt.

4. Repeat this procedure as needed to install cage nuts in all light fixture boxes.

Install light fixtures in panels

Prerequisites: Cage nuts must be installed in each light fixture as directed in “Install cage nuts in the light fixtures” (page 68).

IMPORTANT

Make sure to position the light’s power cord (“whip”) on the back side of the light fixture (i.e., on the side that faces the exterior of the equipment). Wire to NFPA 70 and do not run wiring over the face of beams.

NOTE

Refer to the following diagram as you complete this task.

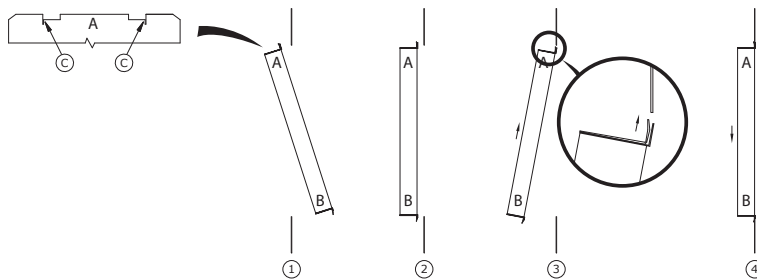

A: Flange with notches
B: Flange without notches
C: Slot in notch

1. Obtain a light box with cage nuts already installed.
2. Stand facing the light panel from the interior and hold the light fixture so that its flanged edge is toward you, with the notched flange "A" on the top.
3. Insert the light fixture into the opening of the panel with flange "A" up.
4. Slide the fixture up until flange "B" engages the lower edge of the opening in the panel; then lower the fixture.
5. Bend the edges of each notch so that the light panel fits into the slot at the corner of the notch.

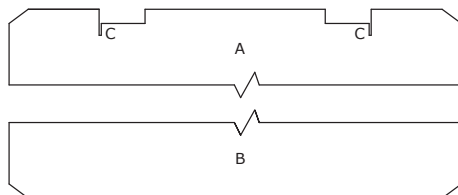

A: Flange with notches
B: Flange without notches
C: Slot in notch

Install covers over light fixtures

Prerequisites: The light fixture must be installed in the light panel as directed in “Install light fixtures in panels” (page 68), with the whip positioned on the back side of the light fixture.

Place a light fixture cover over the light fixture and attach it using 6-mm x 20-mm cap-head screws.

NOTE

To prevent damage to the cover, finger-tighten each of the cap-head screws to a torque rating between 2 and 5 inch-pounds.

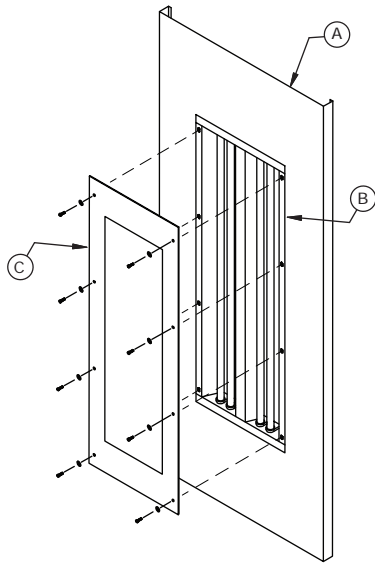

A: Light panel
B: Light fixture installed in light panel
C: Light cover

Install the manometer

Scope: This task applies only to the standard manometer (GFS part number 1011003) paired with GFS single-stage exhaust filter media.

1. Position the manometer on the outside of the booth.

NOTE

Choose a convenient location, approximately 5 feet from the floor and within 3 feet of the filter bank.

2. Drill two holes (1/8-inch or 9/64-inch in diameter) on a vertical line 3-15/16 inches apart for the provided fittings.
3. Loosely mount the manometer with the provided self-tapping screws.
4. Adjust the gauge until the bubble is centered in the level vial, then secure the manometer tightly.
5. Install tubing adapters on each side of the filter.
6. Run tubing:
 - a. Run the high-pressure line (left fitting) to the booth.

- b. Run the low-pressure line (right fitting) to the pit.

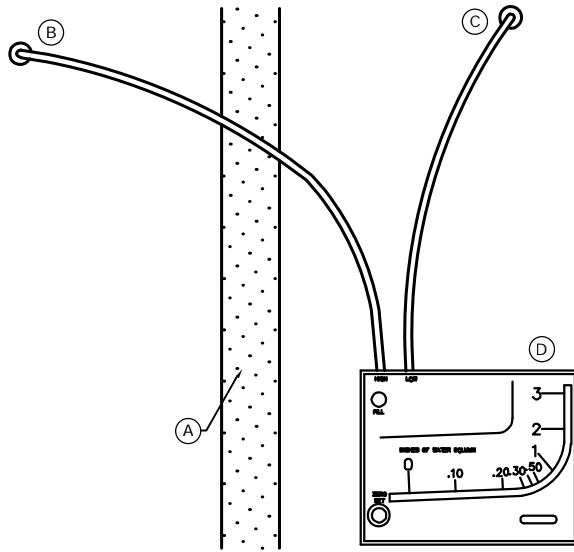

- A: Filter media*
B: High-pressure line to booth side of filters
C: Low-pressure line to chamber side of filters
D: Manometer

7. Turn the white adjustment knob counterclockwise until it stops, then turn clockwise three full turns. This puts zero approximately in the middle of the travel adjustment in either direction.
8. Remove the fill plug and carefully pour the red indicating fluid until it reaches zero on the scale.

NOTE

Minor adjustments can be made by turning the white adjustment knob.

9. Replace the fill plug.

NOTE

If the gauge is overfilled, remove the excess by inserting a pipe cleaner through the fill port to blot up excess fluid.

10. Place the supplied red pointer flag at the appropriate location referenced below (indicating dirty filters):

- **GFS Wave[®]**: 1/2 inch w.c.
- **GFS Poly[™]**: 1/2 inch w.c.

NOTE

For other filters, the differential setting should be adjusted to the manufacturer's recommendations.

Install the control panel

NOTE

The control panel houses Main Disconnect, Lighting, and Motor Branch Circuit Protection per NEC requirements. It also houses all operator controls.

NOTE

This task covers only the mechanical installation of the control box; wiring should be performed by a qualified electrician as specified in “Perform electrical hookup” (page 82).

NOTE

If you mount the control panel to the side of the booth (rather than mounting it to an adjacent wall), GFS recommends that you use strut channel with strut hardware. You can cut the strut to span the distance between booth back brake flanges in the dimensions that will allow the control panel to be mounted to the strut. When mounting large enclosures, GFS recommends that the strut extend up from the floor for extra support. **Strut channel is not provided by GFS.**

Mount the control panel either on the exterior booth wall or an adjacent wall.

NOTE

Position the control panel so that its top is between 70 and 74 inches from the floor. The control panel must be at least 36 inches (914 mm) from any booth opening.

NOTE

Do *not* mount the control panel inside the booth enclosure.

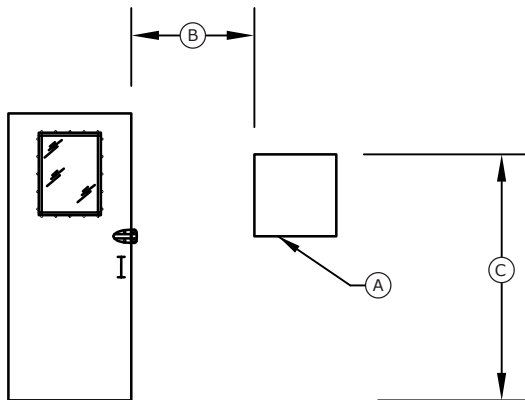

A: Control panel

B: Minimum of 36-inches between the control panel and any booth doors or openings

C: 70 to 74-inches from the floor to the top of the control panel

Install miscellaneous electrical devices

NOTE

Ensure that the placement of all electrical devices meets the NEC requirements for clearance from combustible areas.

NOTE

This section provides instructions for installing miscellaneous electrical devices. As you install each device, retain any unused hardware. Place unused hardware in a bag and tape it to the device so that it will be available for the electrician.

Install proximity switches

Prerequisites: Product doors and personnel doors must be installed.

NOTE

Perform this task only if this booth uses proximity switches. Proximity switches are standard on pressurized booths and an option on non-pressurized booths.

1. Install proximity switches on personnel doors.

NOTE

Locate the proximity switch beside the Brixon latch.

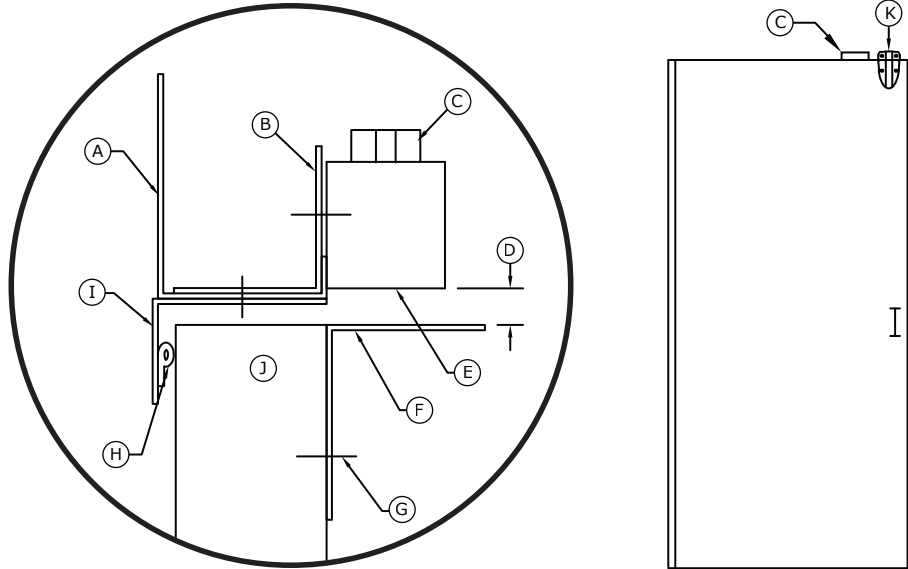

- A: Panel
- B: Proximity mount bracket (BKTG-PS-MDS)
- C: Door limit switch (proximity switch)
- D: 1/4 max
- E: Sensing area
- F: Shutoff bracket
- G: Field-drill and use self-tapping screws
- H: P-seal
- I: Door stop
- J: Personnel door
- K: Brixon latch

2. *If applicable:* Install proximity switches on a non-roll-up product door.

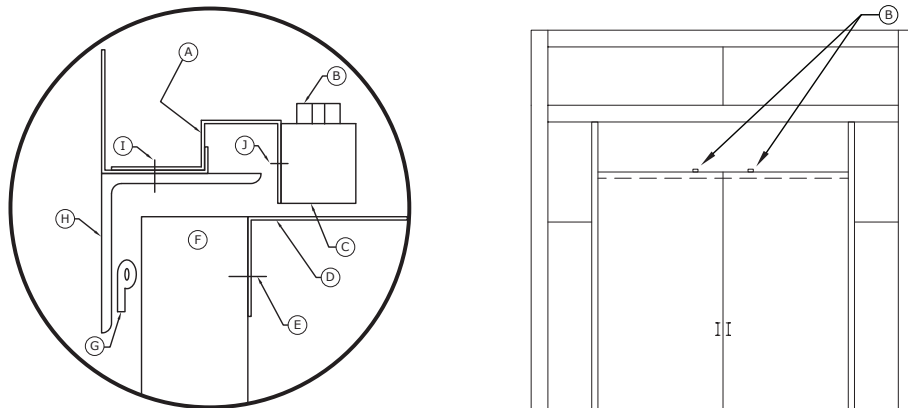

- A: Proximity mount bracket (BKTG-PS-PDS)
- B: Door limit switch (proximity switch)
- C: Sensing area
- D: Shutoff bracket
- E: Use self-tapping screws
- F: Product door
- G: P-seal
- H: Door header
- I: Field-drill and bolt using 5/16-inch x 3/4-inch bolts and nuts
- J: Field-drill and bolt using hardware provided with proximity switch. **The use of power tools or overtightening may result in damage to the device.**

3. *If applicable:* Install a proximity switch on a roll-up product door.

NOTE

You may need to trim or bend the steel rod lever arm of the limit switch (item B, below) for proper contact with the door bottom angle.

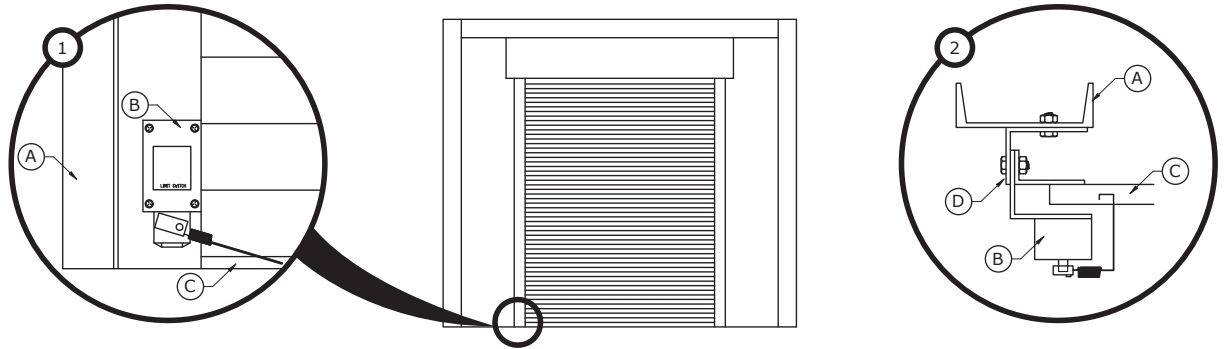

A: Door jamb

B: Door limit switch (proximity switch); trim or bend arm if necessary for proper contact with door bottom angle

C: Roll-up door (bottom angle)

D: Door guide

If applicable: Install the air-sensing tube

Scope: This task applies only if the site purchased the optional air-sensing tube (AST) with their booth.

NOTE

The high-pressure air-sensing pressure tip must be located at least 84 inches from the floor and at least 24 inches from any corner.

NOTE

Refer to the following diagram as you complete this task:

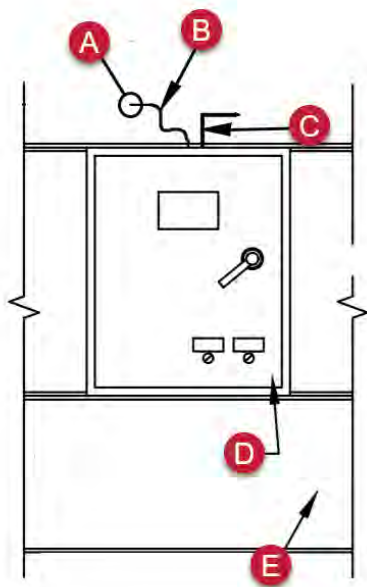

A: High-pressure air-sensing pressure tip (Locate inside the booth a minimum of 84 inches from the floor at at least 24 inches from any corner.)

B: High-pressure air-sensing tube

C: Low-pressure air-sensing pressure tip (factory installed)

D: Control panel

E: Outside booth

1. Drill a 1/4-inch hole through the booth wall panel.

NOTE

The hole must be at least 84 inches from the floor and at least 24 inches from any corner.

2. Push the tubing through the wall.
3. Attach the high-pressure air-sensing pressure tip and secure it to the inside of the booth wall.
4. Attach one end the high-pressure air-sensing tube to the pressure tip and the other end to the designated bulkhead fitting on the control panel.
5. Insert the low-pressure air-sensing tube through the pre-drilled hole in the top of the control panel and attach it with the supplied nut.

If applicable: Install the air-proving switch

Reference: Refer to the instructions for the Airflow Switch Installation in the Electrical Drawings document.

NOTE

For information on locating the Electrical Drawings document, refer to “Gathering required documentation” (page 14).

Install the temperature sensor

NOTE

The temperature sensor must be located no more than eight feet from the outlet of the AMU.

1. Select a location on the AMU ductwork that is near a place where the ductwork penetrates the booth plenum, but is also **within eight feet** of the AMU discharge outlet.

NOTE

The temperature sensor should be placed in an area where the air is well mixed, with even flow.

2. Attach the temperature sensor to the duct with the supplied mounting flange.

Below: Example of temperature sensor placement for a booth-mounted AMU



Below: Example of temperature sensor placement for a roof-mounted AMU



Below: Example of temperature sensor placement for a vertical side-entry AMU



Install the air solenoid valve

Prerequisites: The booth's air supply line must already be installed.

NOTE

This task covers the installation of the directional valve in the compressed air line piping, and is usually performed by a plumber or mechanical contractor. An electrician will perform the wiring from the valve to the control panel, as described in "Perform electrical hookup" (page 82).

Install the air solenoid valve as close as possible to where the compressed air enters the booth, but no closer than 3 feet to any door or opening.

NOTE

Refer to the following diagram to complete this task:

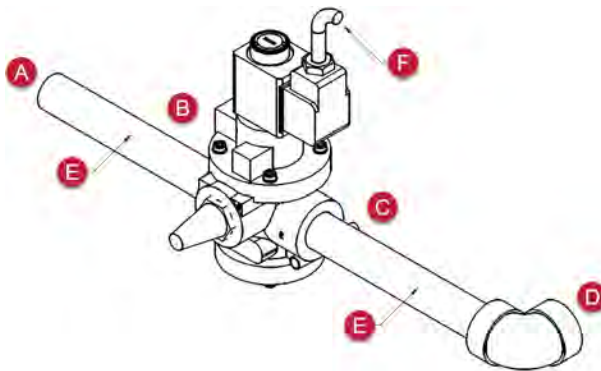

- A:** From building air supply
- B:** Inlet
- C:** Outlet
- D:** Through booth wall
- E:** NPT pipe nipple (size will vary)
- F:** Conduit with wiring to control panel

If applicable: Install the Economy Mode switch

Prerequisites: The booth's air supply line must already be installed.

NOTE

This task applies only if the site purchased the optional Economy Mode switch with the booth.

NOTE

This task covers the installation of the switch in the compressed air line piping and is usually performed by a plumber or mechanical contractor.

NOTE

Compressed air must be clean, filtered, and dry.

Connect the Economy Mode switch into the air line just before the air solenoid valve (i.e., between the air supply coming from the building and the air solenoid valve).

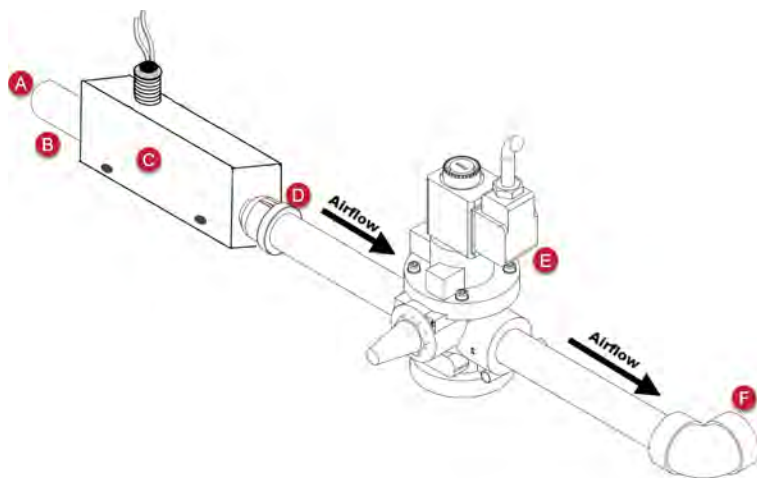

- A: From building air supply
- B: 1/2-inch or 3/4-inch NPT
- C: Economy Switch
- D: Outlet
- E: Air solenoid valve
- F: Through booth wall

NOTE

Install the switch horizontally, with electrical to the top.

Figure 7. Economy Switch Installation (Thomas Products Model Number 1500)

If applicable: Install the gun hanger switch

Scope: This task applies only if the site purchased the optional gun hanger with their booth.

NOTE

The gun hanger is optional hardware that provides a place to store a paint gun when it's not in use. Hanging the paint gun on the gun hanger activates a switch that places the booth into Economy Mode (an energy-saving state). The booth remains in Economy Mode until the paint gun is removed from the hanger.

1. Mount the gun hanger bracket to an interior booth wall using two 5/16-inch bolts.

NOTE

Locate the bracket at about waist height near the most commonly used personnel door.

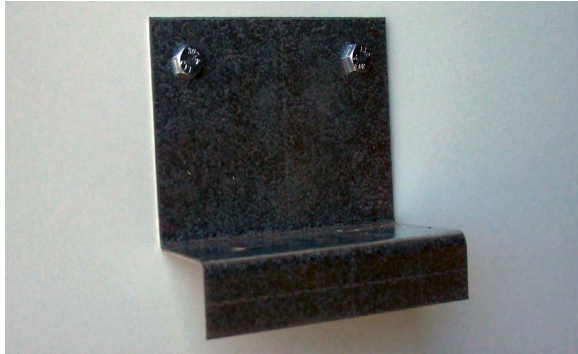

2. Mount the limit switch to the bracket using two 1/4-inch #20 bolts.

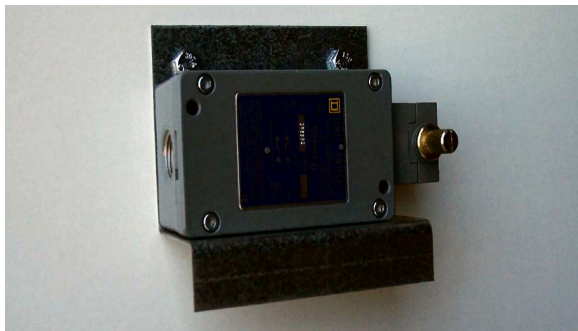

3. Mount the arm and cut off the excess.

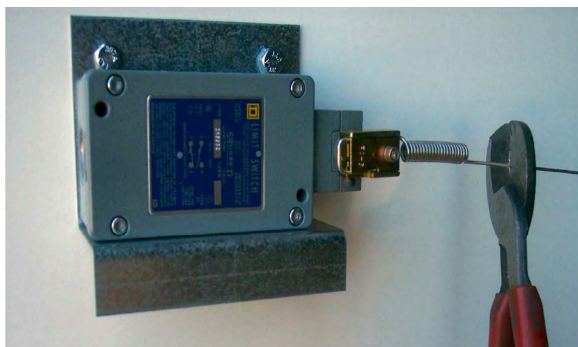

4. Install the hanger in the spring assembly.

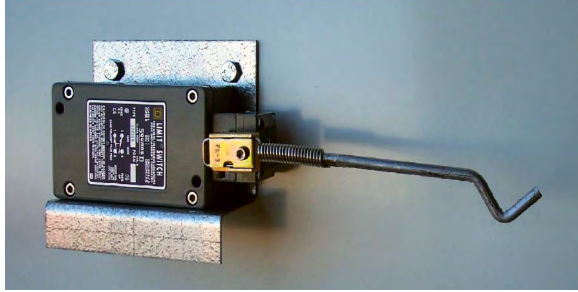

Caulk the booth

Prerequisites: The booth must be assembled and anchored to the floor, with the lights already installed.

NOTE

Do *not* caulk around the light fixtures.

Caulk all booth panel seams, including panel to floor (after the booth is tightened and secured to the floor).

Perform electrical hookup

WARNING

Electrical installation should be completed by a qualified electrician. Installation must meet all applicable national, state, and local electrical codes.

Wire miscellaneous electrical devices

Reference: Refer to the Electrical Drawings document while completing this task.

1. Complete the wiring for the following items:
 - AMU
 - Exhaust fan
 - Control panel
 - Lights
 - Temperature sensor
 - Air solenoid valve
2. Complete the wiring for any of the following items that are included with this booth:
 - *If applicable:* Proximity switches on product doors and personnel doors
 - *If applicable:* Air-sensing tube (AST)
 - *If applicable:* Economy Mode switch and gun hanger

***If applicable:* Install junction box & disconnect switch for roll-up door**

Prerequisite: The roll-up door must be installed.

NOTE

Perform this task only if the booth has a roll-up product door. If the booth has a roll-up door at both the front and rear of the booth, perform this task for both doors.

NOTE

Mount the junction box and the disconnect switch **within three to five feet** of the door opening.

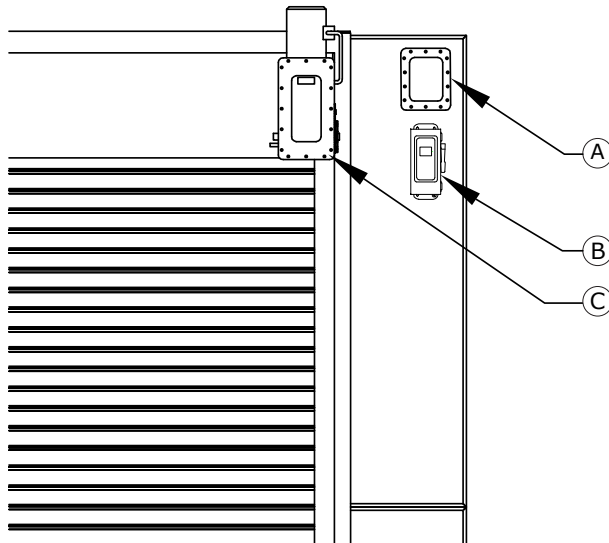

- A: Junction box
- B: Disconnect switch
- C: Door operator

1. Tek-screw the strut channel to the booth panels.

NOTE

Strut channel is not provided by GFS.

2. Attach the junction box to the strut channel using a spring-loaded nut.
3. Attach the disconnect switch to the strut channel using a spring-loaded nut.

Install filters

Prerequisites: Complete all other installation tasks before installing the filters. Waiting until the end of the procedure to install the filters helps ensure that the filters remain clean.

Install the intake filters

NOTE

On a downdraft booth, the intake filters are inserted into the filter racks in the ceiling of each bay.

Insert intake filters into the filter racks so that the tacky side of the filter is toward the air-leaving side of the booth.

NOTE

Ensure that the filter is under the bolt or bolt head, as shown in the inset, below.

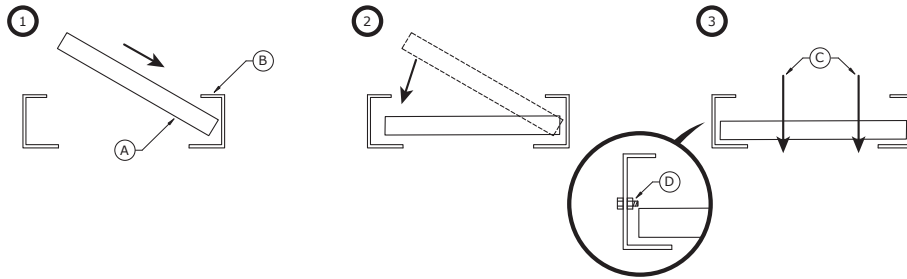

- A: Tacky side of intake filter
- B: Filter rack
- C: Airflow direction
- D: Keep the filter under the bolt or bolt head

Assemble the pit and install the exhaust filter media

Prerequisites: This step assumes that the grating was placed in the pit in “Prepare the pit” (page 29).

NOTE

On a downdraft booth, the exhaust filter media is located in the pit.

Reference: Refer to the Pit Assembly page of the Design Drawings.

1. Remove any boards or other covering you placed over the pit to protect it from debris in “Prepare the pit” (page 29).
2. Remove the bar grating from the pit and set it aside.

WARNING

Fall Hazard: Do not walk or drive over the pit while the bar grating is removed.

3. Place the diffuser trays in the pit, following the pattern shown on the Pit Assembly page of the Design Drawings.
4. Place the wire grid over the diffuser trays.
5. Obtain the supplied roll of 1-inch polyester exhaust filter media.

Place the roll at one end of the pit with the **air leaving side of the filter media facing down**; then roll out the filter media along the length of the pit. Cut off the excess filter media when you reach the opposite end of the pit.

NOTE

The exhaust filter media goes on top of the wire grids.

6. Replace the bar grating on top of the pit.

NOTE

Grating must be installed with cross rods on top.

NOTE

You can walk and drive over the pit or raised basement after the bar grating is installed.

WARNING

Fall Hazard: Do not drive over the bar grating in a vehicle that exceeds the maximum wheel load listed in the Bar Grating Specification table on the Pit Detail page of the Design Drawings.

Startup resources

This section provides helpful information for performing a booth startup.

Startup tools and test equipment

This section lists tools and equipment used during the startup procedure.

Hand tools

- 1/8-inch tip terminal screwdriver
- #2 straight-tip screwdriver
- #2 Phillips screwdriver
- 6-inch adjustable wrench
- 10-mm deep-well socket and ratchet
- Standard hex key (Allen wrench) set
- Adjustable pliers
- Wire stripper

Test equipment

- Digital multi meter with AC and DC capabilities
- Clamp-on ammeter
- Anemometer 25-5,000 FPM range
- Digital manometer with 0.01-20 inch w.c. resolution
- Gas leak detector or soap bottle

Optional equipment

- 0-10 VDC 4-20ma signal generator
- Digital Thermometer
- Non-contact voltage detector

Complete the Customer Pre-Startup Checklist

Scope: This task applies only if the site purchased the GFS factory startup service.

Prerequisites: The booth is fully assembled and an electrician has completed the wiring.

NOTE

This task is the responsibility of the customer.

NOTE

The Customer Pre-Startup Checklist is included with the startup documents that ship in the “Miscellaneous” box.

1. Complete the Customer Pre-Startup Checklist to verify that the booth is ready for startup.
2. Return the completed Customer Pre-Startup Checklist to GFS as directed on the form.

NOTE

If you purchased GFS factory startup, then upon receipt of your completed form, GFS will schedule an authorized startup technician to travel to your site to perform startup, commissioning, and training on the equipment.

Perform the startup procedure

Prerequisites: All applicable services, hookups, and other conditions specified in the Customer Pre-Startup Checklist must be ready.

NOTE

This task is the responsibility of the startup technician.

NOTE

The Startup Checklist and the Startup/Testing Report are included with the startup documents that ship in the “Miscellaneous” box.

1. Complete the tasks in the Startup Checklist to verify that the booth is ready for operation.

NOTE

For recommended tools, see “Startup tools and test equipment” (page 86).

2. *If applicable:* Return the completed Startup Checklist to GFS as directed on the form.
3. Perform booth testing.

NOTE

Inspection results shall be recorded and maintained for at least two years.

4. Notify the customer that the booth is ready for use.

The customer is responsible for completing the Customer Sign-Off Form and returning it to GFS as directed on the form.