



GLOBAL  
FINISHING  
SOLUTIONS



# Ultra<sup>®</sup> CTOF Downdraft Booth with BT Air Heater (Single-Bay)

## Installation Manual

**Document Number:** 239-148 rev 5

Publication date 02/13/2024

*Read and keep this manual for future reference. All personnel operating the equipment described in this manual should review and understand all instructions before use.*

# Table of Contents

Introduction .....	4
About Global Finishing Solutions LLC .....	4
Contacting Global Finishing Solutions .....	4
Target audience .....	4
Conventions used in this manual .....	5
Safety notices .....	5
Information notices .....	5
General safety .....	6
Booth safety .....	9
Booth description .....	12
Preparing for installation .....	13
Accepting delivery of your booth .....	13
Gathering required documentation .....	14
Confirming site requirements .....	15
Confirming booth layout .....	15
About the Design Drawings document .....	18
Page elements .....	18
Page types .....	20
Required materials .....	22
Required tools .....	22
Recommended equipment .....	23
Installation best practices .....	24
Unpack in stages .....	24
Sort parts by size .....	25
Remove protective coating .....	25
Follow assembly guidelines .....	26
Installation procedure .....	27
<i>If applicable:</i> Safeguard the pit .....	27
Prepare the floor .....	27
Mark the booth footprint .....	27
Mark the air heater footprint .....	28
Mark the column positions for the booth frame .....	29
Install the BT air heater .....	30
<i>For BT air heater only:</i> Install the exhaust fan .....	30
<i>If necessary:</i> Install the intake and exhaust stacks now .....	32
<i>If applicable:</i> Assemble the raised basement .....	33
Install the floor channel .....	33
Attach the branding decal and truss cover panels .....	34
Install the booth frame .....	36
Assemble the booth walls .....	37
Build a side wall .....	38

<i>If applicable:</i> Build a solid end wall .....	39
Finish the top of the booth .....	40
Install the roof support assembly .....	40
Install the roof panels .....	40
Install hip light panels .....	40
Install the filter ceiling .....	40
<i>If applicable:</i> Install the AdvanceCure system .....	40
<i>If applicable:</i> Install the AdvanceCure cover kit .....	41
Install curtain track and bracket hardware .....	41
Install the personnel door .....	41
<i>If applicable:</i> Install the corner covers .....	41
Install the diffuser assembly .....	42
Install the intake and exhaust stacks .....	42
Assemble the intake stack .....	42
Assemble the exhaust stack .....	43
<i>If applicable:</i> Install the guy-wire kit .....	44
Install the lights .....	45
<i>If applicable:</i> Install optional booth accessories .....	46
Install the operator interface terminal .....	46
Install miscellaneous electrical devices .....	47
Install the temperature sensor .....	47
Install the air-sensing tube .....	47
<i>If applicable:</i> Install the damper actuators .....	48
Install the air solenoid valve .....	49
Install the Economy Mode switch .....	50
Install the air-proving switch .....	50
<i>If applicable:</i> Install the puff switch .....	51
Secure the wall panels to the floor profile .....	51
Caulk the booth .....	51
<i>If applicable:</i> Install vehicle ramps and landing step .....	51
Prepare the air heater for startup .....	51
<i>If applicable:</i> Install the curtain .....	52
Install booth filters .....	52
Install the filter racks and intake filters .....	52
Install exhaust filter media in the pit or raised basement .....	52
Perform electrical hookup .....	53
Perform commissioning and startup .....	55

# Introduction

## About Global Finishing Solutions LLC

### Leading the Industry in Paint Booth and Finishing System Technology

With decades of experience, Global Finishing Solutions is the leading manufacturer of paint booths and finishing systems for many industries, including automotive refinish, aerospace and defense, industrial manufacturing, woodworking, and large equipment. By combining high-quality components, strong relationships with paint manufacturers, and our experienced distribution network, GFS provides the best equipment and support to set your business up for success.

## Contacting Global Finishing Solutions

### General information

- Toll-free: 800-848-8738
- Fax: 715-597-2193
- Email: [info@globalfinishing.com](mailto:info@globalfinishing.com)
- Online: [www.globalfinishing.com](http://www.globalfinishing.com)

### Technical support

- Toll-free: 800-848-8738
- Fax: 715-597-8818
- Email: [techservices@globalfinishing.com](mailto:techservices@globalfinishing.com)

### Parts and filters

- Toll-free: 800-848-8738
- Fax: 888-338-4584
- Email: [parts@globalfinishing.com](mailto:parts@globalfinishing.com)

## Target audience

This document is intended for use by trained, experienced paint booth installers and maintenance technicians. If you have questions about the installation procedure described in this manual, contact GFS as described above.

## Conventions used in this manual

This section describes how information is presented, organized, and referenced within this manual.

### Safety notices

This manual uses the following standards to identify conditions related to safety hazards and equipment damage.

**Table 1. Safety notices**

Symbol	Description
<b>DANGER</b>	Indicates an imminent hazard that will result in death.
<b>WARNING</b>	Indicates a hazard that can result in serious personal injury or death.
<b>CAUTION</b>	Indicates a hazard that can result in personal injury.
<b>NOTICE</b>	Indicates a situation that can result in equipment or property damage, but poses no risk of personal injury.

### Information notices

In addition to the safety notices described above, this manual uses a boldface keyword to identify certain other types of information.

**Table 2. Information notices**

Keyword	Description
<b>NOTE</b>	Denotes general information that provides additional context or guidance.
<b>Important</b>	Denotes information to which you should pay special attention.
<b>Reference</b>	Directs you to related content in a separate document.
<b>Prerequisites</b>	Specifies other tasks that must be completed or conditions that must exist before you perform the current task.
<b>Scope</b>	Describes limitations to the current task or conditions under which the task applies or does not apply to the procedure.

# General safety

Follow all safety guidelines when assembling, operating, or servicing this product.

## **WARNING**

There are inherent hazards associated with the operation and service of this equipment. For your personal safety, observe all safety information. Failure to observe these safety practices can result in personal injury or death.

## **WARNING**

Operation and maintenance of this product must be performed properly by qualified personnel who observe the warnings in all documentation and notes provided with and on the product.

## **WARNING**

Follow all general standards for installation and safety for work on installations. Follow all good practices for the proper use of lifting tackle and equipment. The use of protective equipment such as safety goggles and protective footwear must be considered.

## **WARNING**

All persons who will operate, service, inspect, or otherwise handle this product must read and understand the safe operating practices, safety precautions, and warning messages in this documentation.

## **WARNING**

The roofs of GFS equipment are not designed or intended to be walked upon or to support weight of any kind. As designed and manufactured, equipment roofs do not meet the minimum requirements of a safe walking and/or working surface under OSHA 1910.22. Under no circumstances should the roof be used by maintenance personnel or others for walking, standing, or storage of any kind. When necessary, roof access should be secured through the use of a properly supported platform that satisfies the minimum load requirements specified by ASCE 7 (Minimum Design Loads and Associated Criteria for Buildings and Other Structures) and ASCE 37 (Design Loads on Structures during Construction). Additionally, personnel should always utilize appropriate fall safety protocols when using an elevated platform. Use of the roof in a contrary manner may result in injury and/or death.

## **WARNING**

Comply with OSHA guidelines and with all applicable local electrical, safety, and fire codes and standards.

## **WARNING**

All field wiring provided must comply with local codes or, in the absence of local codes, the National Electrical Code (NFPA 70). Article 516 covers applicable of flammable and combustible materials.

## **WARNING**

Electrical installation should be completed by a qualified electrician. Installation must meet all applicable national, state, and local electrical codes.

## **WARNING**

Ensure that all electrical components are grounded to a central ground.

**WARNING**

Disconnect and lock out the main electrical service before installing, adjusting, or servicing the product.

**WARNING**

Lockout the main gas shutoff valve before maintenance or inspection of the air heater.

**WARNING**

Guards and covers that prevent contact with electrically energized or moving parts are required and must not be removed or left open during operation.

**WARNING**

Welding, cutting, and other spark-producing operations shall not be permitted in or adjacent to a booth until a written permit authorizing such work has been issued. The permit shall be issued by a person in authority following his or her inspection of the area to ensure that precautions have been taken and will be followed until the job is completed.

**WARNING**

Local fire and building codes require fire protection. Check with local inspector authorities for requirements.

**CAUTION**

Read and save these instructions before attempting to assemble, install, operate, or maintain the product described. Protect yourself and others by observing all safety information. Failure to comply with instructions could result in personal injury and/or property damage. Retain these instructions for future reference.

**CAUTION**

This manual contains statements that relate to worker safety. Read this manual thoroughly and comply as directed. Operate this equipment in accordance with the guidelines set forth in this manual. It is impossible to list all potential hazards of this equipment. Instruct all personnel involved with this equipment in the safe conduct and operation of the system. GFS recommends that only qualified personnel operate and maintain this equipment.

**CAUTION**

Safety signs, panels, and labels that are normally affixed to the product must be replaced immediately if illegible or missing.

**CAUTION**

New or replacement parts that are installed during repair or maintenance must include all safety signs, panels, and labels as specified by the manufacturer. These must be affixed to the new or replacement parts as specified by the manufacturer.

**CAUTION**

Where applicable, use earplugs or take other safety measures for hearing protection.

**NOTICE**

The product must be installed and serviced only by a trained, qualified service technician. Incorrect installation may void the warranty.

**NOTICE**

If you have questions about the warranty, please contact your distributor prior to contacting GFS.



# Booth safety

## **DANGER**

**Ceiling panel load capacity for installation and maintenance:** You must use temporary platforms that span at least two structural frames for maintenance. **Do not walk on or apply any pressure to lights or explosion (deflagration) relief panels.**

## **WARNING**

All equipment must be operated and maintained in accordance with local, state, and federal (OSHA) requirements governing occupational safety, fire protection, and booth operations. Operators must read and understand GFS and included independent equipment and/or component manufacturer's instructions prior to use. **Disclaimer:** GFS is not responsible for any injury, illness, or property damage that results from not abiding by local, state, or federal (OSHA) requirements that govern occupational safety, fire protection, and booth operations. GFS is also not responsible for any injury, illness, or property damage that is the result of not adhering to GFS and/or independent equipment/component operating, service, maintenance, and/or installation requirement's or directives.

## **WARNING**

Install the booth in compliance with locally enforced codes and standards.

## **WARNING**

A fire suppression system is required by the International Fire Code and NFPA 33. A fire suppression system is not supplied with this booth.

## **WARNING**

Do not allow overspray to accumulate on the inside of the paint booth walls. When overspray accumulates, remove it as soon as possible to prevent a possible fire hazard. Use a non-ferrous, non-sparking scraper to eliminate any possibilities of igniting combustible material.

## **WARNING**

Do not leave piles of paint sweepings in the booth as it creates a possible fire hazard.

## **WARNING**

Treat used filters and any other paint-contaminated items as flammable products and dispose of them safely.

## **WARNING**

If coatings containing nitrocellulose are sprayed in the booth, all residue must be removed from exhaust diffuser components and all exhaust filters must be changed at least once a day.

**WARNING**

Improper disposal of used filters may cause spontaneous combustion. You must consult local authorities for proper storage and disposal requirements. Guidelines include:

- Immediately remove all contaminated filters from the paint booth.
- Discard filters to a safe, detached location, place them in a non-combustible container with tight-fitting lid, or place them in a water-filled metal container to prevent a possible fire hazard.
- Disposal varies depending on the type of paint that is being captured. Consult local authorities for storage and disposal requirements.

**WARNING**

Duct the exhaust air from the fan away from the working environment to the outdoors. Do not operate the booth unless exhaust has been ducted properly.

**WARNING**

Isolate the outdoor vent from air-conditioning intakes, windows, and any other equipment that may recirculate the exhaust indoors.

**WARNING**

Turn on the exhaust fan before using the booth. Ensure that the exhaust fan is operating correctly before entering the booth.

**WARNING**

Check local codes to see if a booth interlock is required. A booth interlock prevents the spray devices from operating unless the exhaust fan is operating.

**WARNING**

Some spray activities may require the use of respiratory protection.

**WARNING**

Use an OSHA-approved paint spray respirator when spraying in the booth.

**WARNING**

This equipment is designed for the removal of particulate matter only. Reduction of volatile organic compounds (VOCs) requires either coating reformulation or optional, additional equipment.

**WARNING**

**Fall Hazard:** Do not walk or drive over the pit without the bar grating in place.

**WARNING**

**Fall Hazard:** Do not drive over the bar grating in a vehicle that exceeds the maximum wheel load listed in the Bar Grating Specification table on the Pit Details page of the Design Drawings.

**WARNING**

**Fall Hazard:** Do not remove bar grating from the pit unless authorized to do so. The pit presents a fall hazard when the bar grating is not installed.

**CAUTION**

Become familiar with all controls before operating or servicing this booth.

**CAUTION**

Proper door alignment is critical to the operation of the booth. Ensure that there is equal space around the doors. Move the bottom of the door jamb to the left or right or in and out until the doors are sealed and plumb.

**CAUTION**

If this installation includes pumps or compressors, install and connect those devices in accordance with the manufacturer's documentation.

**NOTICE**

GFS recommends storing crates indoors pending installation. If you must store crates outside, protect crates and their contents from moisture to prevent damage to equipment.

**NOTICE**

Install the control panel per NFPA 70 and local codes and standards.

**NOTICE**

Failure to anchor the booth structure to the floor properly may result in structural damage.

**NOTICE**

GFS does not provide materials for constructing the pit. It is up to the customer to arrange for the actual construction of the pit.

# Booth description

GFS' Ultra Closed-Top Open-Front (CTOF) Booth line provides a versatile, end-to-end finishing environment that allows vehicles to be filled, primed, sealed, painted, and cured in one location.

Generally accepted as the best airflow style, downdraft booths do an excellent job controlling overspray and contamination. Air enters the booth through a filtered ceiling plenum, flows vertically over the product, and into the filtered exhaust pit in the floor.

## NOTE

At sites where a traditional pit is not possible, a booth can be constructed with a “raised basement” instead of a pit. A raised basement makes it easier to move the booth to a different location, and can reduce construction time.

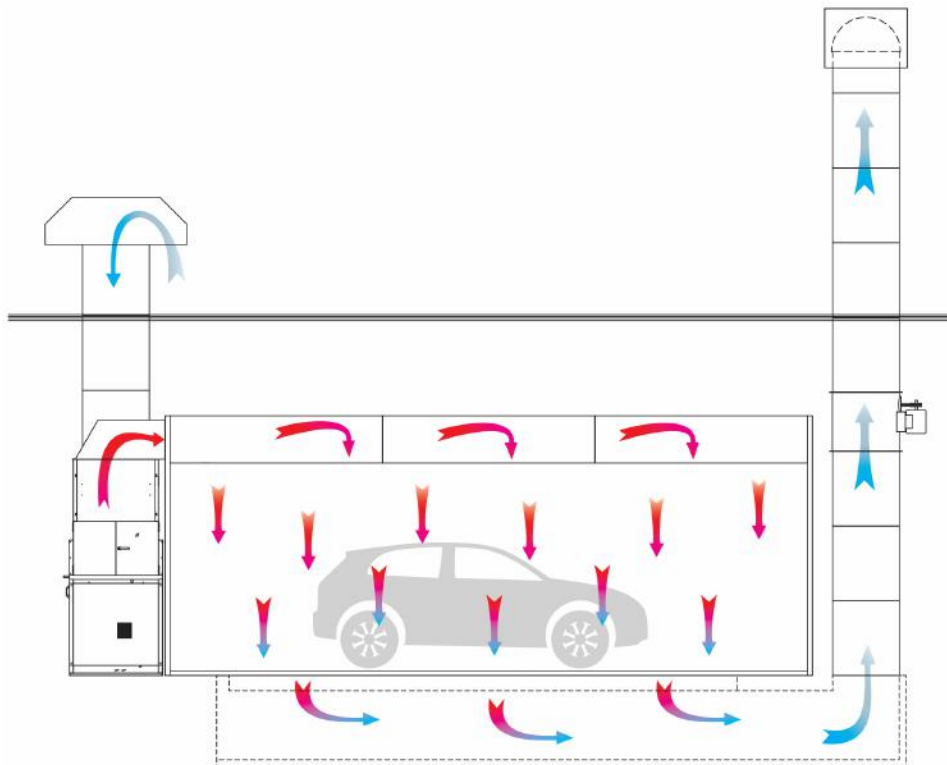

Figure 1. Airflow in a downdraft booth with a BT air heater

# Preparing for installation

## Accepting delivery of your booth

The booth is delivered unassembled, in multiple crates.

Upon delivery, count the number of crates you received and compare that number to the expected number per the Bill of Lading. Also inspect each crate for any signs of damage during shipment.

### **NOTE**

If you see shipping damage, note it on the freight carrier's paperwork; failure to do so may result in claim denial.

**If any parts are missing or damaged**, contact Global Finishing Solutions at 800-848-8738 to speak to a Technical Service Representative.

### **NOTICE**

GFS recommends storing crates indoors pending installation. If you must store crates outside, protect crates and their contents from moisture to prevent damage to equipment.

## Gathering required documentation

Ensure that you can locate these documents and that they are available during the installation procedure.

### NOTE

Certain manuals, project drawings, and the Job-Specific Guide are also provided electronically to distributors via box.com. Many manuals are available for download on [globalfinishing.com](http://globalfinishing.com).

**Table 3. Additional documentation**

Document	Description	How provided
Design Drawings	Provides instructions for assembling this particular booth and includes information about the booth order, configuration, and components.	Ships in the “Miscellaneous” box
Electrical Drawings	Provides wiring diagrams for electrical components.	Ships inside the air heater control panel
Control Panel Operator Manual	Setup and operation instructions for the appropriate control panel: <ul style="list-style-type: none"> <li>• Engage® Control Panel Operator Manual</li> <li>• LOGIC 3 Control Panel Operator Manual</li> <li>• LOGIC 4 Control Panel Operator Manual</li> </ul>	Ships inside the air heater control panel
<i>If applicable:</i> Air heater owner’s manual	Installation, operation, and maintenance instructions for the air heater; either: <ul style="list-style-type: none"> <li>• GUL/BT Series Owner’s Manual (for GUL and BT air heaters)</li> <li>• SpaceSaver® Series Owner’s Manual</li> </ul>	Ships inside the air heater control panel
Final Commissioning Document (D0420)	Includes all tasks related to booth startup and commissioning.	Ships inside the air heater control panel

## Confirming site requirements

Before beginning the installation procedure, confirm that the site where the equipment will be assembled meets the following requirements:

- The floor where you will assemble the paint booth is level.

### NOTE

If the floor is more than 1 inch out of level, you must shim or grout the floor to avoid any misalignment.

- The area is large enough to allow a minimum of 3 feet (914 mm) of clear space on all four sides of the booth, taking into account if additional space is needed for an air heater or Air Make-Up Unit. Check local codes and refer to NFPA guidelines to determine particular space allowances.
- There is sufficient overhead clearance for an exhaust unit and the exhaust ductwork in the area where the equipment is to be located.
- If the booth does not include the raised basement option, then the pit is already constructed and meets the following criteria:
  - The dimensions of the pit correspond to the site drawings provided by GFS.
  - The pit is situated so that the booth can be centered over the pit and still have the required clearances.
- A licensed electrician has verified that the incoming power meets the requirements specified for the equipment. (The power specification is included with the submittal or provided at delivery.)
- The appropriate devices for lifting/rigging are available onsite. (Either purchased from GFS with the booth, or obtained elsewhere by the customer.)
- The appropriate miscellaneous hardware kits are available on-site. (Either purchased from GFS with the equipment, or obtained elsewhere by the customer.)

## Confirming booth layout

Before beginning the installation procedure, review the booth configuration and layout with the end user. Be sure you understand what options this booth includes and how the end user wants to arrange the booth.

The GA page of the Design Drawings shows one *possible* booth layout. However, end users might want their booths arranged differently. **During installation, you must make the appropriate adjustments to the instructions to accommodate the actual booth layout.**

For best results, review the GA page of the Design Drawings drawing with the end user and discuss the items listed below:

- Does the booth use a pit or a raised basement?
- If this booth uses a raised basement, where does the end user want to place the air heater? (See Table 4.)
  - Right side, toward back of booth
  - Right side, toward front of booth
  - Left side, toward back of booth
  - Left side, toward front of booth

- At the rear of the booth (solid-back booth only; not available for drive-through booths)
- Is this booth a drive-through booth (a booth with a product door or curtain on each end) or a solid-back booth?
- Where does the end user want to locate the personnel door?
  - On the left or right side of booth?
  - At which panel position?
- Where does the end user want to place the operator interface terminal/HMI?

**NOTE**

Per NEC, the operator interface terminal cannot be located within 3 feet of any door opening. Refer to the HMI Installation page of the Design Drawings for more information about placement restrictions.

- On an exterior booth wall? (If so, specify which.)
- On a nearby wall? (If so, determine distance and orientation relative to booth.)
- *If applicable*: Within the booth’s interior, how does the end user want to arrange the wall lights?
- If the booth includes standard options and accessories, where should those items be located? (Examples include additional light fixtures, rotating access tables, observation windows, parts hangers, additional personnel doors, etc.)

**Table 4. Air heater positions**

Air heater position relative to booth <sup>1</sup>		
Layout <sup>2</sup>	Description	
Right-back <sup>3</sup>	Right side, toward back of booth	
Right-front	Right side, toward front of booth	
Left-back	Left side, toward back of booth	



Air heater position relative to booth <sup>1</sup>		
Layout <sup>2</sup>	Description	
Left-front	Left side, toward front of booth	
Back <sup>4</sup>	At rear of booth	

<sup>1</sup>These options for air heater position apply only to a booth that uses a raised basement instead of a traditional pit. If the booth uses a pit, the heater position is determined by the pit placement.

<sup>2</sup>Air heater position is defined by the booth wall to which the heater connects (left side wall, right side wall, or back wall). When the air heater connects to the left or right side wall, the description also indicates whether the air heater is closer to the front or back of the booth.

<sup>3</sup>The “right-back” air heater position is the default layout depicted on the GA page of the Design Drawings.

<sup>4</sup>This option is available only for a booth that has a solid-back rear wall; not available for drive-through booths.

# About the Design Drawings document

Use this manual in conjunction with the provided Design Drawings document. This Design Drawings document defines the overall layout and detailed structure of your particular booth. If applicable, it also includes exploded-view diagrams and parts lists for each section (or subassembly) of the booth.

## Page elements

Pages within the Design Drawings document contain the following elements:

- **Title block:** The title block is located along the right edge of each page. It contains the model information, drawing identification label or number, the order/serial number, and other information.
- **Model Info:** Contains text that identifies each page within the Design Drawings document, e.g., "Overall Assembly". When the installation instructions refer you to a specific page within the Design Drawings, look for that text in the Model Info field. (For a description of the various page types that might be included in your Design Drawings document, see "Page types" (page 20).)
- **Scale:** If the drawing is to scale, the scale is defined here (e.g., 3/16" = 1' 0"). Otherwise, this field contains "NTS," or "Not to Scale."
- **Drawings:** The main area of each page can contain any or all of these types of drawings:
  - An exploded and/or assembled view of the product or subassembly
  - Additional views or "Detail" drawings
- **Bill of Materials:** Any page that includes a drawing with labeled parts also includes a table that lists each item number with its corresponding part number and quantity.
- **Quantity per Booth:** Pages that show a subassembly of the product and list the quantity provided of that particular subassembly.
- **Notes:** Pages within the Design Drawings often contain notes that provide information about how to install that particular section or subassembly.

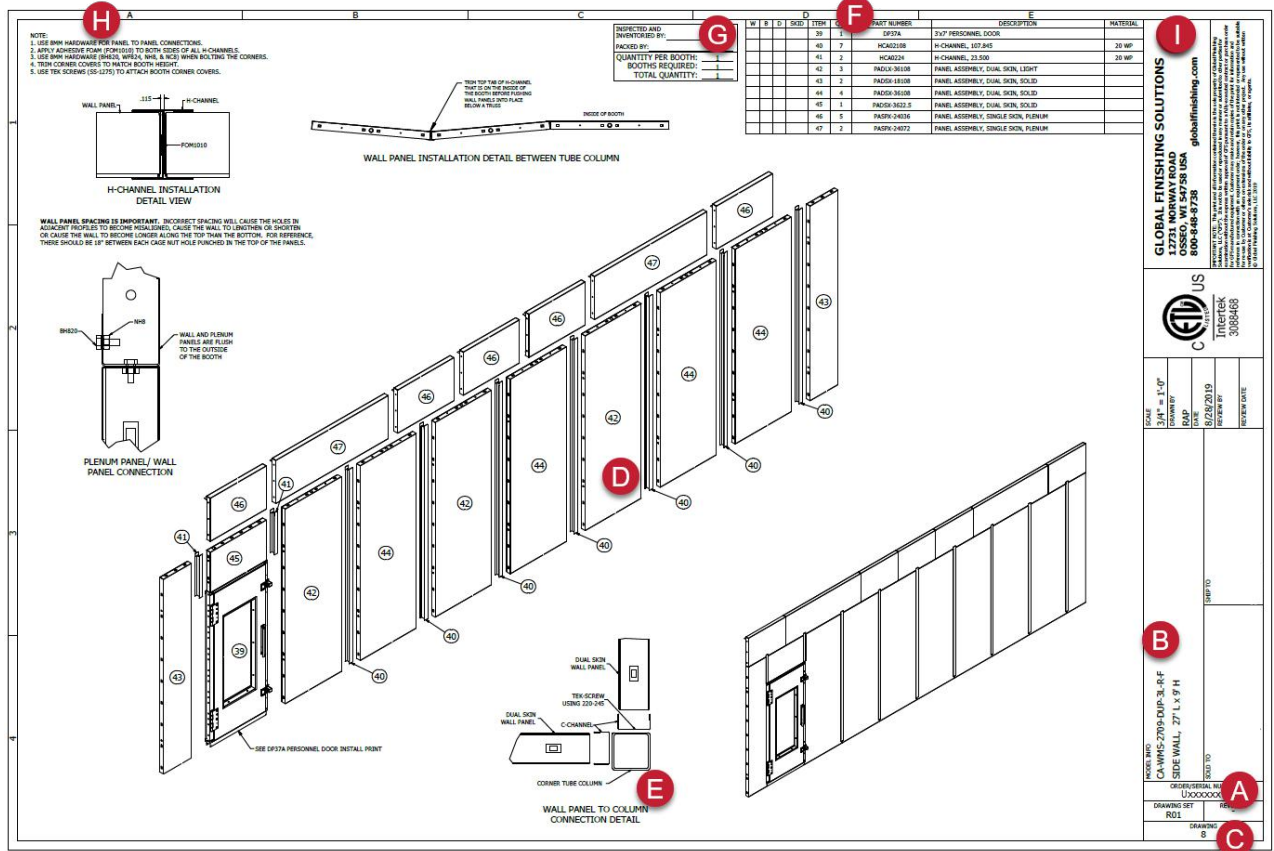

- A:** Serial number
- B:** Model info
- C:** Drawing number
- D:** Drawings: Main view (exploded and/or assembled)
- E:** Drawings: Detail view
- F:** Bill of materials
- G:** Quantity per booth
- H:** Notes
- I:** Title block

## Page types

The Design Drawings document may contain any of the following pages that apply to your particular product.

**Table 5. Page names in the Design Drawings document**

Page name	Description
AdvanceCure	Provides instructions for installing the optional GFS AdvanceCure System.  <b>NOTE</b> This page applies only to booths that include AdvanceCure.
AdvanceCure Intake & Discharge Cover Kit	Shows how to install cover plates at locations where the optional GFS AdvanceCure System integrates with the booth.  <b>NOTE</b> This page applies only to booths that do <b>not</b> include the AdvanceCure.
Air Heater	Provides instructions for installing the air heater base and burner.
Air Inlet Hood	Shows how to assemble the air inlet hood that goes on top of the intake stack.
Basement	Shows how to install a raised basement for a downdraft booth.  <b>NOTE</b> A raised basement can be used in place of a traditional exhaust pit.
Basement Ramp Assembly	Shows how to assemble vehicle ramps.  <b>NOTE</b> This page applies only to downdraft booths that use a raised basement instead of a traditional pit.
Booth Caulking Guide	Provides instructions for applying caulk to the booth.
Corner Light Harness	Shows how to run the wire harness cables to the optional corner light from the control panel.
Corner Light Installation	Shows how to install optional corner lights.
Diffuser Assembly	Shows how to install the diffuser for an air heater with side-entry into the booth plenum.
Discharge Hood Assembly	Shows how to assemble the discharge hood that connects the air heater to the booth plenum.  <b>NOTE</b> This page applies only to booths that have a BT or GUL air heater.
Exhaust Yoke	Shows an exploded view of the exhaust yoke located at the rear of the booth.  <b>NOTE</b> This page applies only to semi-downdraft booths.
Filter Ceiling	Shows how to install the filter ceiling and roof supports.
Floor Profile	Shows how to install the floor channel and floor-leveling components.
Floor Profile Tek-Screw Detail	Shows how to secure the wall panels to the floor profile.
Front Wall	Shows an exploded view of a drive-through end wall (a wall that accepts a product door).  <b>NOTE</b> A Front Wall assembly is always installed at the front of the booth. For drive-through booths (which have a product door at each end), a Front Wall assembly is <i>also</i> installed at the rear of the booth.

Page name	Description
GA	<p>Provides a top view of the booth as well as front, side, and rear elevations.</p> <p><b>NOTE</b> The GA page shows the standard booth arrangement and is provided for reference only; it is <i>not</i> customized for the booth you are building.</p> <p><b>NOTE</b> The actual placement of some components (such as the air heater, personnel door, wall lights, etc.) might be different than shown on this page. <b>Always consult with the end user for placement details</b>, as described in “Confirming booth layout” (page 15).</p>
Hip Panels	Shows how to install the hip light panels.
HMI Installation	Provides instructions for installing the operator interface terminal.
Install Curtains	Shows how to install curtain mounting tracks.
Locking Rod	Shows how to install the locking rod assembly for product doors.
Label Placement Instructions	Shows where to place various booth labels, including exit, maintenance, and safety labels.
Landing Step for Personnel Door	<p>Shows how to assemble a platform for the personnel door.</p> <p><b>NOTE</b> This page applies only to booths that use a raised basement instead of a traditional pit.</p>
Light Fixture Details	Shows how to install booth lights.
Overall Assembly	Shows an exploded view of the entire booth; identifies the major components and sub-assemblies of the booth.
Personnel Door	Shows how to install a personnel door and its associated hardware.
Pit Assembly	Shows how to install diffuser trays, filter media, and bar gratings in the exhaust pit of a booth.
Pit Details	<p>Provides instructions for constructing the exhaust pit for a booth.</p> <p><b>NOTE</b> End users are responsible for constructing the pit prior to booth installation.</p> <p><b>NOTE</b> On the Pit Details page, the title block’s Drawing field contains the word “Pit” instead of a sequential sheet number.</p>
Rear Wall	<p>Shows an exploded view of a solid end wall.</p> <p><b>NOTE</b> This page applies only to booths that are not drive-through booths.</p>
Recirc Duct Assembly	Shows how to assemble and install the ductwork that goes between a recirc air heater and the exhaust yoke.
Reflector Light Fixture	Shows how to install the optional light-reflector kit.
Roof Panels	Shows how to install the roof panels.
Roof Support Assembly	Shows how to install the roof support assembly.
Side Wall	<p>Shows an exploded view of a side wall.</p> <p><b>NOTE</b> The Design Drawings always contains two Side Wall pages: one that includes a personnel door, and one that does not include a door.</p>
Temp Sensor & Diffuser/Baffle	Provides instructions for installing the temperature sensor and a diffuser (for an air heater with side-discharge into the booth) or a baffle (for an air heater with down-discharge into the booth).
Wire Harness	Shows how to run the wire harness cables for the lights to the air heater control panel.

# Required materials

This section lists the tools, equipment, and documentation required for installing your booth.

## NOTE

Depending on the type of equipment you are installing, additional tools may be required.

## Required tools

- Screwdrivers
- Wrenches and socket set
- Hammer and mallet
- Load bar that can extend to at least 9 feet (108 inches)
- Filter-insertion tool (metal pizza cutter; approximately 3-inch to 4-inch diameter)
- Drift pins (two per person; 1/8-inch to 5/8-inch taper)
- Caulk gun
- Impact driver and drill
- Unibit or step drill bits
- Chalk and/or felt-tip marker (for marking initial measurements on floor)
- Chalk-line tool
- 4-foot box level
- Laser level (*Suggested:* Quad laser or rotary laser level)
- Tape measures (35-foot and 100-foot)
- Tin snips
- Duct crimping tool
- Torque nut runner
- Reciprocating saw
- *Optional:* Torch and welder in case modifications need to be made on site
- Tools required for decal placement:
  - Stiff squeegee
  - Spray bottle with soapy-water mixture
  - Paper towels
  - Scissors
  - Masking tape
  - Marker

## Recommended equipment

- Ladders (6-foot and 8-foot)
- Two or more sawhorses
- Two 26-foot T scissor-lift platforms
- Warehouse forklift with 5000-pound lift weight and a maximum lift height higher than 16 feet

### **NOTE**

Lifts and cranes are not required, but they may improve both the safety and speed of installation.

### **NOTE**

The end user is responsible for providing any lifts, cranes, and material handlers. Alternatively, the end user can coordinate with the installer so the installer can rent those items before starting the work.

# Installation best practices

## Unpack in stages

As you begin each section of the installation procedure, unpack the crate(s) that contain the parts for that section. In general, the skids are organized so the parts that go together during assembly are packed on the same skid.

### NOTE

For faster unpacking, use a reciprocating saw to cut the crates.



**Figure 2. Skids awaiting unpacking**

A packing list is attached to each crate. As you unpack a crate, compare all the parts with that crate's packing list to check for shortages or losses in transit. Also check parts for any damage that might have been caused in shipping.

### NOTE

Slightly bent panels and angle braces can be straightened and will cause no performance or assembly problems.

**If any parts are missing or damaged**, contact Global Finishing Solutions at 800-848-8738 to speak to a Technical Service Representative.



## Sort parts by size

To help installation proceed more efficiently, sort all parts by size as you unpack them (Figure 3).

Each part has a specific part number. The part number is either etched into the part or printed on a label affixed to the part (Figure 4).



Figure 3. Panels sorted by size in preparation for assembly

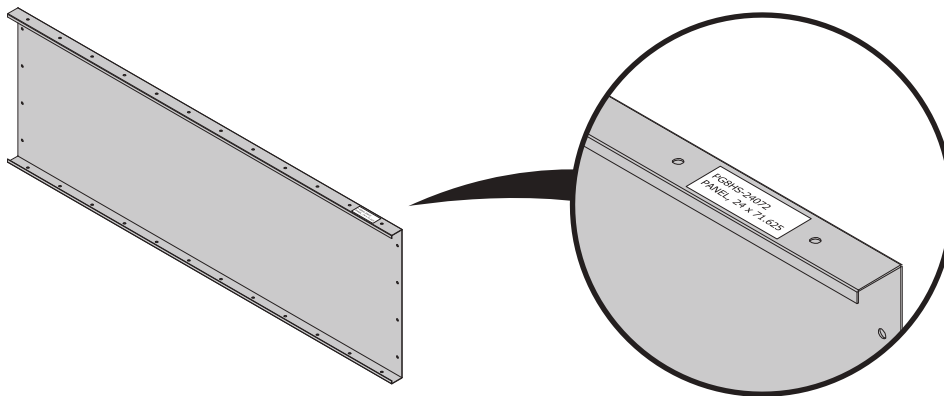

Figure 4. Example of a part number label

## Remove protective coating

Some booth parts ship with a protective coating. For efficiency during installation:

- Remove the part number label from the part and set the label aside temporarily.
- Remove the blue protective coating from the part.
- Re-apply the part number label on the part. (Use tape to affix the label to the part, if necessary.)

## Follow assembly guidelines

Follow these guidelines when assembling the booth:

- Assemble the booth in sections, following the sequence provided in this document.
- As you build each section, tighten the bolts only to finger-tight.
- Before tightening the bolts within a section, confirm that the section is plumb and square.
- When directed to do so, tighten the bolts within a section to *snug-tight*. Snug-tight is defined as “the tightness that is attained with a few impacts of an impact wrench or the full effort of an ironworker using an ordinary spud wrench to bring the plies into firm contact.” (RCSC 2014)
- **For dual-skin booths:** Orient panels and parts as shown on the assembly drawings.
- **For single-skin booths:** Orient panels so that each panel’s flanged side faces outward, and the non-flanged side faces the booth’s interior.
- **For all booths:** When applicable, orient bolts so that the bolt heads (and a washer) are on the booth’s interior and the threads are on the exterior.
- Use hardware as specified on the assembly drawings.
- Plumb the panels so that they are perpendicular to the floor. The sides of the booth must be parallel to each other.

# Installation procedure

This procedure describes how to install a single-bay Ultra XD or XS CTOF booth with a BT air heater.

## ***If applicable: Safeguard the pit***

**Scope:** This task applies only to a booth that uses a traditional pit (either a 1-, 2-, or 3-row pit). If this booth uses a raised basement instead of a pit, skip this task and continue to “Prepare the floor” (page 27).

**Prerequisites:** The end user must have already installed the exhaust pit in accordance with the specification on the Pit Details page of the Design Drawings.

### **NOTE**

This task ensures that the pit is safe to drive or walk across during booth assembly.

**Reference:** Refer to the Pit Assembly page of the Design Drawings.

1. **For a 2-row or 3-row pit:** Install the pit supports.

### **NOTE**

If this booth uses a 1-row pit, skip this step and continue to step 2.

### **NOTE**

Pit supports must be anchored to the walls and floor of the pit. GFS does not provide the anchors.

2. Place the bar grating in the pit.

### **NOTE**

Grating must be installed with cross rods on top.

### **NOTE**

You can walk and drive over the pit or raised basement after the bar grating is installed.

### **WARNING**

**Fall Hazard:** Do not drive over the bar grating in a vehicle that exceeds the maximum wheel load listed in the Bar Grating Specification table on the Pit Details page of the Design Drawings.

3. Cover the airflow openings with plywood and mark them as holes so no one will drive over them.

### **NOTE**

Refer to the Pit Details page of the Design Drawings for more information.

## **Prepare the floor**

### **Mark the booth footprint**

**Prerequisites:** If this booth uses an exhaust pit, the pit should already be safeguarded as described in “*If applicable: Safeguard the pit*” (page 27).

**Reference:** Refer to the Floor Profile page of the Design Drawings.

1. Sweep the floor clear of debris.
2. Use a laser level to check the floor:
  - If the floor is out of level by **1 inch or less** over the full length of the booth, continue to the next step. (You do not need to take any corrective action now because you will be able to correct for slope when you install the floor leveling components later in the procedure.)
  - If the floor is **more than 1 inch** out of level over the full length of the booth, shim or grout the floor as needed to get it to within 1 inch of level. GFS does not provide shims.
3. Referring to the **Inside-to-Inside Width** and the **Inside-to-Inside Length** shown on the Floor Profile page of the Design Drawings, measure the booth's footprint on the floor and mark the corners.

**NOTE**

If this booth has a pit, position the footprint so that it is centered (lengthwise) over the pit.

**NOTE**

Ensure that the location allows for the clearances around the booth as specified in "Confirming site requirements" (page 15).

**NOTE**

Use a piece of chalk or other temporary mark at this stage, in case you have to adjust the position of the marks in the next step.

4. Measure the diagonals to confirm that the opposite sides are parallel and that adjacent sides are perpendicular to each other.

Re-measure and adjust the corner markings as needed until the diagonals are equal length.

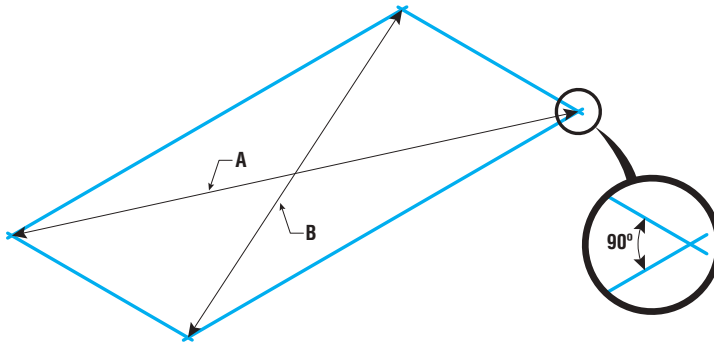

5. After confirming that the measurements are correct and the angles are 90 degrees, snap chalk lines to mark the outline of the booth's footprint.

## Mark the air heater footprint

**Prerequisites:** The booth footprint must already be marked on the floor as described in "Mark the booth footprint" (page 27).

## NOTE

The location where the air heater is placed must meet the following requirements:

- **If this booth uses a traditional pit**, the air heater must be positioned over the air-return hole (for a BT heater), or over the combined air-return/exhaust hole (for a GUL heater). Refer to the Pit Details page of the Design Drawings for more information.
- **If this booth uses a raised basement**, the location should follow the end user's preference for the position of the air heater relative to the booth (either right-back, right-front, left-back, left-front, or back of booth), as described in "Confirming booth layout" (page 15).
- The location must provide the required distance between the air heater and the inner edge of the floor channel (from the Air Heater Placement detail on the Air Heater page of the Design Drawings).
- The location must provide the required minimum clearances around the air heater (from the Plan View on the GA page of the Design Drawings).

**Reference:** Refer to the Air Heater page of the Design Drawings.

1. Identify a location that meets the requirements listed above; then measure the air heater's footprint on the floor and mark the corners.

## NOTE

The air heater dimensions are provided on the Air Heater page of the Design Drawings.

## NOTE

Use a piece of chalk or other temporary mark at this stage, in case you have to adjust the position of the marks in the next step.

2. Measure the diagonals to confirm that the opposite sides are parallel and that adjacent sides are perpendicular to each other.

Re-measure and adjust the corner markings as needed until the diagonals are equal length.

3. Snap chalk lines to mark the outline of the air heater.

## Mark the column positions for the booth frame

**Prerequisites:** The booth footprint must already be marked on the floor as described in "Mark the booth footprint" (page 27).

1. Mark the position of the two foremost truss support columns (one column on the left side of the booth and one column on the right side).

## NOTE

Refer to the Floor Profile page of the Design Drawings.

2. *If applicable:* Mark the position of the two rear-most truss support columns (one column on the left side of the booth and one column on the right side).

## NOTE

This step applies only if the booth is a drive-through booth.

## NOTE

Refer to the Floor Profile page of the Design Drawings.

## Install the BT air heater

**Prerequisites:** The air heater footprint must already be marked on the floor as described in “Mark the air heater footprint” (page 28).

**Reference:**

- Refer to the Air Heater page of the Design Drawings while completing this task.
  - Refer to the air heater’s owner manual for additional installation, operation, maintenance, and safety information.
1. Place the air heater’s base section in its designated position (denoted by the air heater footprint marked on the floor).

**NOTE**

Be sure to orient the base appropriately for the intended booth layout.

2. Ensure that the base section is level front-to-back and side-to-side.
3. Build the discharge hood as directed on the Discharge Hood Assembly page of the Design Drawings.
4. Place the assembled discharge hood on top of the air heater’s burner section and bolt it into position.
5. Place the burner section (with discharge hood assembly installed) on top of the base and bolt it into position.

## *For BT air heater only: Install the exhaust fan*

**Scope:** This task applies only if the booth uses a BT air heater. If this booth uses a GUL air heater, skip this task.

**NOTE**

This task also includes installation of the ductwork that runs from the exhaust-stack opening at the pit to the exhaust fan.

**NOTE**

To connect duct sections together:

- Slip the bottom of one duct section into the top of the previous duct section.
- Ensure that the duct section is level north-south and east-west.
- Tek-screw the duct section to the previous duct section from the inside out.

**NOTE**

When placing the exhaust fan, observe the airflow and blade rotation indicators on the outside of the exhaust fan housing.

**Reference:** Refer to the diagram below and to the RH Side Elevation view on the GA page of the Design Drawings.

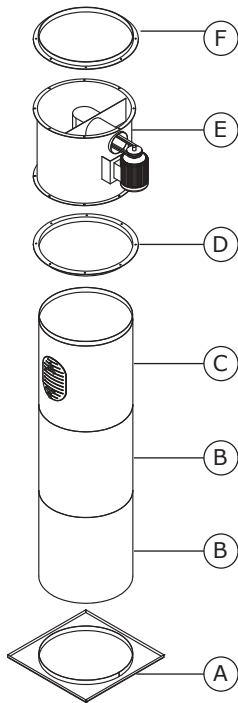

**A:** Exhaust-stack base plate

**B:** Plain duct section

**C:** Clean-out duct (plain duct section with clean-out door)

**D:** Fan ring (flange up; duct lip down)

**E:** Exhaust fan

**F:** Fan ring (flange down; duct lip up)

1. Install the exhaust-stack base plate:
  - a. Remove any plywood or other protective covering that you placed over the exhaust-stack opening in “If applicable: Safeguard the pit” (page 27).
  - b. Field drill the exhaust-stack base plate with holes for anchoring.
  - c. Place the exhaust-stack base plate over the exhaust-stack opening with the duct lip facing up.
  - d. Anchor each corner of the exhaust-stack base plate.

**NOTE**

GFS does not provide anchors.

- e. Apply caulk around the outside of the exhaust-stack base plate.
2. Install the first section of plain duct:
  - a. Place a plain duct section over the duct lip of the exhaust-stack base plate.
  - b. Ensure that the duct section is level north-south and east-west.
  - c. Tek-screw the duct section to the duct lip from the inside out.
3. Install the second section of plain duct.

**NOTE**

Follow the procedure for connecting duct sections together in the notes at the beginning of this task.

4. Connect the clean-out duct to the previous duct section.

**NOTE**

Follow the procedure for connecting duct sections together in the notes at the beginning of this task.

5. Connect a fan ring to the clean-out duct:
  - a. Orient the fan ring with the duct lip facing down and the flange facing up.
  - b. Slip the duct lip into the top of the clean-out duct.
  - c. Tek-screw the fan ring to the duct from the inside out.
6. Use a forklift to place the exhaust fan onto the fan ring, orienting the fan so that the fan motor points to the appropriate side of the booth.

**NOTE**

Refer to the GA page of the Design Drawings to see how the fan motor should be oriented relative to the booth.

7. Bolt the fan to the fan ring using 8-mm hardware (nuts, bolts, and washers).

**NOTE**

Tighten the bolts to finger-tight until they are all installed; then tighten them to snug-tight.

8. Connect another fan ring to the flange on the top of the exhaust fan.

**NOTE**

Orient this fan ring with its flange facing down and duct lip facing up. Bolt the fan ring to the fan as described in the previous step.

9. Working down from the upper fan ring to the exhaust-stack base plate, caulk the outside of all connections.

**NOTE**

Caulk all duct-to-duct connections and all assembly seams.

## ***If necessary: Install the intake and exhaust stacks now***

**Scope:** This task applies only if the site's layout will make it difficult to access the air heater after the booth is assembled. If you will have easy access to the air heater after the booth is built, skip this task.

**NOTE**

A site's physical layout might make it difficult to access the air heater after the booth is assembled. In such cases, you should install the intake and exhaust stacks now, before you build the rest of the booth. Otherwise, some booth components will be in the way when you build the stacks.

Jump ahead in the procedure to "Install the intake and exhaust stacks" (page 42) and follow the directions there to install the intake stack and exhaust stack; then resume the procedure from this point.

**NOTE**

An end user who is installing the optional guy-wire kit (on either or both stacks) can proceed with that work as soon as you have completed the full stacks. See "*If applicable: Install the guy-wire kit*" (page 44) for more information.



## ***If applicable: Assemble the raised basement***

**Scope:** This task applies only to a booth that uses a raised basement instead of a traditional pit. If this booth uses a pit, skip this task.

- The booth footprint must already be marked on the floor as described in “Mark the booth footprint” (page 27).
- The air heater must already be installed as directed in “Install the BT air heater” (page 30).

### **NOTE**

Do not install the diffuser trays, wire grid, or filter media during this step. Those items will be installed later in the procedure (see “Install exhaust filter media in the pit or raised basement” (page 52)).

**Reference:** Refer to the Basement pages of the Design Drawings. (The Design Drawings contains two Basement pages, numbered “x.1” and “x.2,” where “x” is the overall sheet number for the Basement print in this particular drawing set. The sheet number is located in the lower right corner of the print.)

1. **Referring to the Basement “x.1” page of the Design Drawings:** Install the beams that form the sides and ends of the basement.

### **NOTE**

If necessary, grout and shim the perimeter beams to ensure that they are not more than 1 inch out of level. GFS does not supply shims.

### **NOTE**

Field-cut holes for the intake and/or exhaust in the appropriate perimeter beam.

2. Working from the outside in, install the center beams, connector angles, and beam spacers.
3. **Referring to the Basement “x.2” page of the Design Drawings:** Install the close-off panels:
  - **For basement rows where diffuser trays will be installed** (during a later step): Install a short close-off panel at each end of the row.
  - **For all other basement rows** (that is, rows that will *not* have diffuser trays): Install close-off panels along the entire row.
4. Place the bar grating in all basement rows.

### **NOTE**

Grating must be installed with cross rods on top.

### **NOTE**

You can walk or drive over the basement floor after the bar grating is installed.

### **WARNING**

**Fall Hazard:** Do not drive over the bar grating in a vehicle that exceeds the maximum wheel load listed in the Bar Grating Specification table on the Pit Details page of the Design Drawings.

## **Install the floor channel**

**Prerequisites:** The air heater must already be installed. In addition, if this booth uses a basement instead of a traditional pit, the basement must already be installed.

**Reference:** Refer to the Floor Profile page of the Design Drawings.

1. Install the floor outer profiles.

**NOTE**

If necessary, grout and shim the floor outer profiles to ensure that they are not more than 1 inch out of level. GFS does not supply shims.

2. Anchor the floor outer profiles to the building floor.

**NOTE**

GFS does not provide the anchors.

3. Install and level the panel leveling profiles.

## Attach the branding decal and truss cover panels

**Reference:**

- For steps related to wall assembly, refer to the Front Wall page of the Design Drawings.
- For steps related to the GFS Ultra CTOF decal, refer to the Label Placement Instructions page of the Design Drawings. Also see “Required tools” (page 22) for a list of tools required for decal placement.

1. Obtain the truss cover panels and place the center panel across two sawhorses with its exterior side facing up.
2. Inspect the truss cover panel and ensure that it is clean.

**NOTE**

If necessary, spray the panel with soapy water and wipe it dry with a lint-free cloth.

3. Ensure that your hands are clean; then obtain the GFS Ultra CTOF decal from the Miscellaneous box.
4. Lightly fold the decal in half and create a slight indentation at the middle of the decal; then place masking tape to mark the middle of the decal.



5. Locate the center of the truss cover panel; then use masking tape to temporarily secure the center of the decal to the center of the panel.

**NOTE**

Orient the decal so that it will be right-side up when the panel is installed.



6. Pull back one side of the decal as far as possible (up to where the center of the decal is taped to the panel) and liberally spray the panel beneath with soapy water.

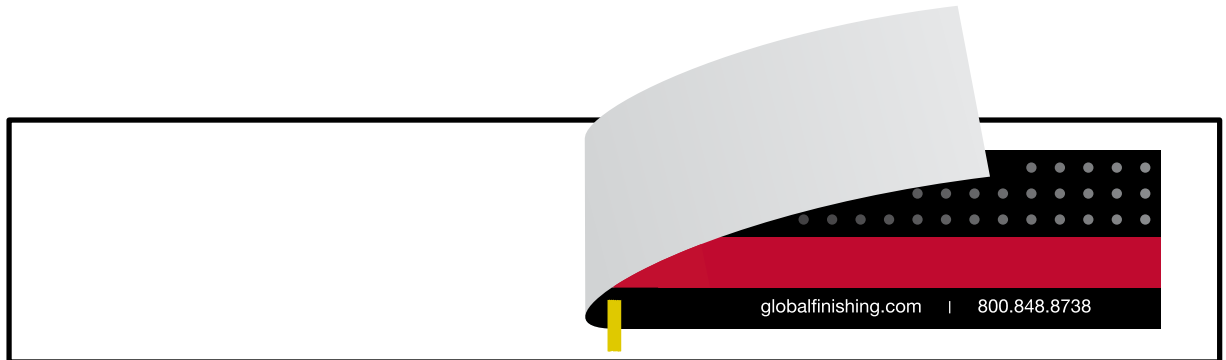

7. Create a starting point near the center of the decal for peeling off the backing:
  - a. Working as closely as possible to where the center of the decal is taped to the panel, carefully separate the backing from the decal.
  - b. Cut or tear the backing across the height of the decal (in as straight a line as possible) to make a starting point for peeling.

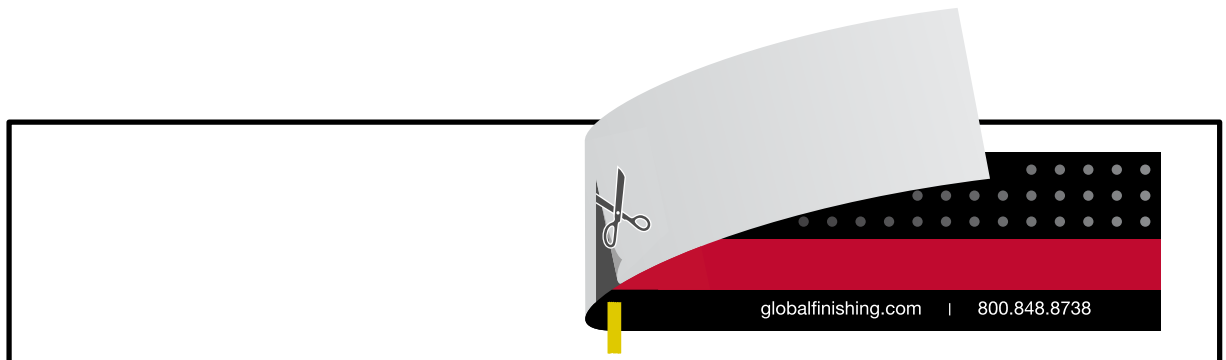

8. Grasp the cut (or torn) edge of the backing paper for the side of the decal that is folded back; then begin peeling off the backing paper as you lay the folded-over half of the decal back onto the panel. Every few inches, use the plastic squeegee to remove wrinkles and air bubbles. Continue peeling off the backing and smoothing the decal onto the panel with the squeegee until that half of the decal is fully applied.

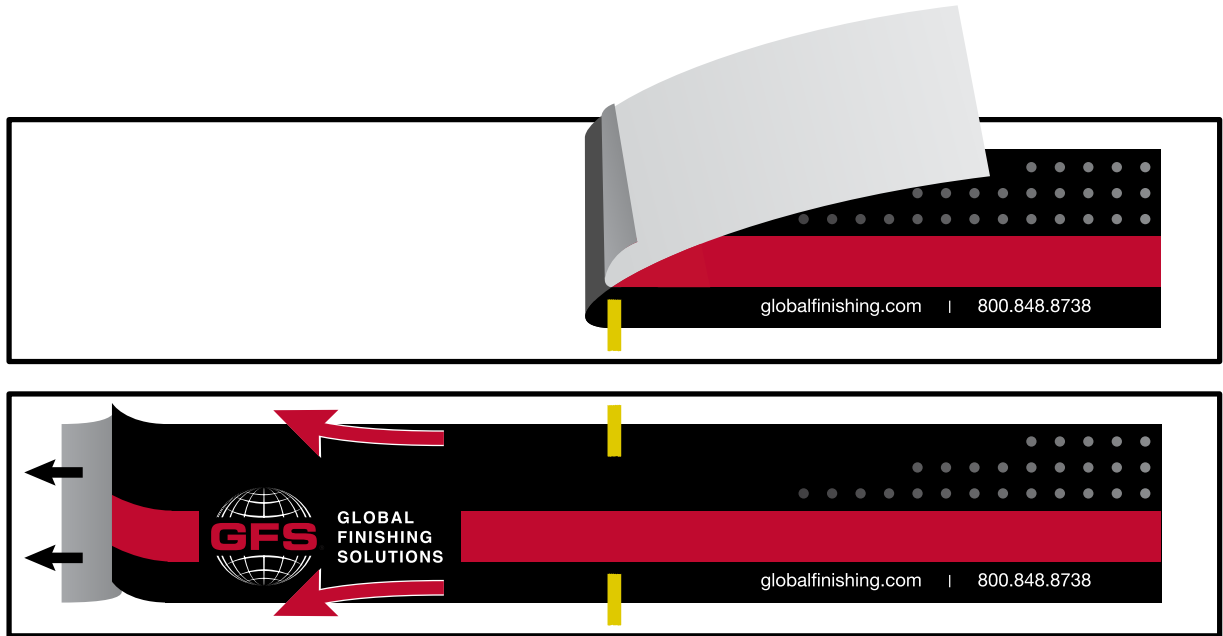

9. Remove the masking tape from the decal.
10. Affix the other half of the decal to the panel:
  - a. Pull back the other side of the decal as far as possible (up to where the first side is affixed to the panel).
  - b. Liberally spray the panel beneath the folded-back half with soapy water.
  - c. Repeat step 8 for this half of the decal.
11. Wipe off any excess water from the decal and panel.
12. Attach the truss cover panels (with decal already applied) to the truss.

**NOTE**

Ensure that the GFS Ultra CTOF decal faces the booth's exterior.

**NOTE**

After installing the panel, double-check for hand prints or smudges; clean the panel, if necessary.

## Install the booth frame

**Scope:** This task always applies to the front end wall. If this booth is a drive-through booth (that is, if it has a curtain at both the front and rear of the booth), then this task also applies to the rear end wall.

**Prerequisites:**

- The branding label must be attached to the truss cover panel.

**Reference:** Refer to the Structural Frame Assembly page of the Design Drawings to assemble the truss support columns and truss(es).

1. Place each column into position:

- a. Shim and grout the columns as necessary.

**NOTE**

GFS supplies the column shims.

- b. Secure the columns to the floor with two expansion anchors.

**NOTE**

GFS does not supply the anchors.

2. Use a forklift to lift the truss into position, then secure it between the two foremost columns.
3. Install temporary bracing on either the left or right side of the frame.

**NOTE**

You can either brace the columns to a building wall or install cross-bracing between the middle and front columns.

**NOTE**

GFS does not supply the bracing.

4. *If applicable:* Repeat the steps above for the rear end wall if this is a drive-through booth.

**NOTE**

A drive-through rear end wall also requires a branding decal attached to the truss cover panel.

## Assemble the booth walls

**Prerequisites:** The floor channels must already be installed and leveled.

**IMPORTANT**

The drawings on the GA page of the Design Drawings show *one possible* booth layout. However, the end user might want to arrange the booth differently than shown. **Be sure you understand how this particular booth is to be arranged.** For more information, see “Confirming booth layout” (page 15).

Follow this **General Wall Sequence** when building the booth walls:

1. Build the wall that connects to the air heater.
2. Build whichever adjacent wall is closer to the air heater.
3. Build the wall that is opposite the air heater.
4. Build the remaining wall.

**To build the first wall:**

- If the air heater connects to the **left or right side** of the booth, follow the instructions in “Build a side wall” (page 38).
- If the air heater connects to the **rear wall**, follow the instructions in “*If applicable:* Build a solid end wall” (page 39).

## Build a side wall

### NOTE

Perform this task at the appropriate time within the General Wall Sequence described in “Assemble the booth walls” (page 37).

**Reference:** Refer to the Side Wall page of the Design Drawings.

### NOTE

The Design Drawings contain two Side Wall pages: one that includes a personnel door, and one without a personnel door. Use the appropriate page depending on whether the particular side wall you are building includes a personnel door or not.

### NOTE

When building a wall that includes a door, use the Side Wall page of the Design Drawings (with personnel door) as a guide, but adjust the position of the door depending on where the end user wants the door located. The personnel door can be swapped with any 36-inch vertical side-wall panel. Install any panels and channels that frame the door, but **do not hang the door or install any door hardware during this step.**

### NOTE

Build the side wall in sections, with each section consisting of a few vertical panels and the horizontal plenum panel that spans them.

1. Starting from either end of the wall, install the vertical wall panels (and adjacent channels, if applicable) that will fit under the first plenum panel.

### NOTE

Channels are applicable only for dual-skin booths.

2. Install a horizontal plenum panel (and tie angle, if applicable) above that group of vertical wall panels.

### NOTE

Tie angles are applicable only for single-skin booths.

### NOTE

**If the air heater connects into this wall, then:**

1. When you reach the place where the air heater will connect, install that plenum panel temporarily and mark the discharge opening. (For dimensions, refer to the Discharge Opening view on the Air Heater page of the Design Drawings.)
2. After marking the cutout, remove the panel and cut the hole for the discharge opening. (BE CAREFUL NOT TO CUT PLENUM PANEL STIFFENERS.)
3. Install the panel (with cutout) in the appropriate position.
3. Repeat step 1 and step 2 to build the next section of wall.  
Continue installing the wall in sections until the side wall is complete.
4. Ensure that the completed wall is plumb, square, and level.

5. Tighten all bolts in the wall to snug-tight.
6. Have all four walls been assembled?
  - **If No:** Build the adjoining end wall that comes next in the General Wall Sequence.
  - **If Yes:** Install the roof support assembly.

### ***If applicable: Build a solid end wall***

**Scope:** This task applies only if the booth does *not* have a curtain at the rear of the booth.

#### **NOTE**

Perform this task at the appropriate time within the General Wall Sequence described in “Assemble the booth walls” (page 37).

**Reference:** Refer to the Rear Wall page of the Design Drawings.

1. Starting from either end of the wall: Install the vertical wall panels, the adjacent channels (if applicable), and the corner angles.

#### **NOTE**

Do not install the corner covers at this time. (You will install them later in the procedure; see “*If applicable: Install the corner covers*” (page 41).)

#### **NOTE**

Channels are applicable only for dual-skin booths.

2. Install the horizontal header panel (and tie angles, if applicable) above the vertical wall panels.

#### **NOTE**

Tie angles are applicable only for single-skin booths.

#### **NOTE**

**If the air heater connects into this wall, then:**

- a. Install the header panel temporarily and mark the discharge opening. (For dimensions, refer to the Discharge Opening view on the Air Heater page of the Design Drawings.)
  - b. After marking the cutout, remove the panel and cut the hole for the discharge opening. (BE CAREFUL NOT TO CUT PLENUM PANEL STIFFENERS.)
  - c. Install the panel (with cutout) in the appropriate position.
3. Ensure that the completed wall is plumb, square, and level.
  4. Tighten all bolts in the wall to snug-tight.
  5. Have all four walls been assembled?
    - **If No:** Build the adjoining end wall that comes next in the General Wall Sequence.
    - **If Yes:** Install the roof support assembly.

## Finish the top of the booth

### Install the roof support assembly

**Prerequisites:** The booth side walls must already be installed.

**Reference:**

- To see the location of the roof support assembly relative to the rest of the booth, refer to the Overall Assembly page of the Design Drawings.
- For installation instructions, refer to the Roof Support Assembly page of the Design Drawings.

### Install the roof panels

**Prerequisites:** The roof support assembly must already be in place.

**NOTE**

For booths with a recirc air heater, explosion relief is required for compliance with NFPA 33. Refer to the guidelines on the Exhaust Yoke page of the Design Drawings.

**Reference:** Refer to the Roof Panels page of the Design Drawings.

### Install hip light panels

**Reference:** Refer to the Hip Panels page of the Design Drawings.

1. Starting at the rear on either the left or right side of the booth:
  - a. Tek-screw a hip light end panel to the exhaust yoke.
  - b. Working forward, install hip light panels (and hip light panel gussets, if applicable) until you reach the front wall.
2. Repeat step 1 on the opposite side of the booth.

### Install the filter ceiling

**Prerequisites:** The roof support assembly, roof panels, and hip light panels must already be installed.

**NOTE**

Do not install the filter racks or the intake filters during this step. You will be directed to do so later in the procedure (see “Install the filter racks and intake filters” (page 52)).

**Reference:** Refer to the Filter Ceiling of the Design Drawings.

## ***If applicable:* Install the AdvanceCure system**

**Scope:** This task applies only if this booth includes the GFS AdvanceCure System.

**Prerequisites:** The roof panels must already be installed.



**Reference:** Refer to the AdvanceCure pages of the Design Drawings. (The Design Drawings contain four pages, numbered “x.1” through “x.4,” where “x” is the overall sheet number for the print in this particular Design Drawings document. The sheet number is located in the lower right corner of the print.)

**NOTE**

Install the AdvanceCure filters during this task, as directed on the AdvanceCure “x.3” page of the Design Drawings.

## ***If applicable:* Install the AdvanceCure cover kit**

**Scope:** This task applies only if this booth does not include the optional GFS AdvanceCure System.

**Prerequisites:** The roof panels must already be installed.

**Reference:** Refer to the AdvanceCure Intake & Discharge Cover Kit page of the Design Drawings.

## **Install curtain track and bracket hardware**

**Reference:** Refer to the Install Curtains page of the Design Drawings for instructions on installing the curtain hardware.

1. Install the track for the frontal curtain (and for the rear curtain, if this is a drive-through booth).
2. Install the brackets into the track.

**NOTE**

Do not install the curtain during this step.

## **Install the personnel door**

**Prerequisites:** The side wall where the door will be located must already be installed (including door posts, door header, and threshold).

**Reference:** Refer to the Personnel Door page of the Design Drawings.

**NOTE**

**For dual-skin booths:** Read and follow the Dual Skin Installation notes on the Personnel Door page of the Design Drawings.

## ***If applicable:* Install the corner covers**

**Prerequisites:** All four booth walls must already be assembled.

**Reference:** Refer to the appropriate page of the Design Drawings depending on the type of end wall that adjoins each corner.

- **For a solid end wall:** Use the Rear Wall page of the Design Drawings.

## Install the diffuser assembly

**Prerequisites:** The booth walls must already be installed and the discharge opening must already be cut in the appropriate panel on the wall that connects to the heater.

**Reference:** Refer to the Diffuser Assembly page of the Design Drawings.

## Install the intake and exhaust stacks

**Scope:** If you installed the intake and exhaust stack earlier in the procedure, skip this task and continue to “Install the lights” (page 45).

### Assemble the intake stack

**Prerequisites:** The base section(s) of the air heater must already be installed as described in “Install the BT air heater” (page 30).

#### IMPORTANT

If the roof opening is already cut, install all intake ductwork (including the air inlet hood) during this step. If the roof opening is *not* cut, install the intake ductwork to just below the roof. (In that case, you will have to finish installing the rest of the ductwork later, after the roofer has cut the roof opening.)

#### NOTE

Per NFPA 33, the air inlet hood on top of the intake stack and the automatic roof ventilator (ARV) on top of the exhaust stack must be at least 10 feet away from each other.

#### NOTE

To connect duct sections together:

- Slip the bottom of one duct section into the top of the previous duct section.
- Ensure that the duct section is level north-south and east-west.
- Tek-screw the duct section to the previous duct section from the inside out.

**Reference:** Refer to the RH Side Elevation view on the GA page of the Design Drawings for the intake stack duct sequence.

1. Connect the first section of plain duct:
  - a. Place a section of plain duct over the intake opening on the base of the air heater.
  - b. Ensure that the duct section is level north-south and east-west.
  - c. Tek-screw the duct from the inside out.
2. *If applicable:* Continue connecting all necessary plain duct sections as required for the intake stack.

#### NOTE

Follow the procedure for connecting duct sections together in the notes at the beginning of this task.

3. Assemble the air inlet hood.

**NOTE**

For instructions, refer to the Air Inlet Hood page of the Design Drawings.

- a. Orient the base plate assembly with the duct lip facing down and insert it into the top section of plain duct.
  - b. Level the base plate square-to-round; then Tek-screw the base plate to the duct section from the inside out.
  - c. Assemble the two end panels and the top panel of the air inlet hood.
  - d. Install the two side panels on the air inlet hood.
  - e. Install the two screen panels on the air inlet hood.
  - f. Place the assembled hood onto the base plate and ensure that it is level north-south and east-west.
  - g. Bolt the sides of the hood to the base plate and Tek-screw the screen to the base plate.
4. Working down from the air inlet hood to the air heater, caulk the outside of all connections in the intake stack.

**NOTE**

Caulk all duct-to-duct connections and all assembly seams.

## Assemble the exhaust stack

**Prerequisites:** The exhaust fan must already be installed.

**IMPORTANT**

If the roof opening is already cut, install all exhaust ductwork (including the ARV) during this step. If the roof opening is *not* cut, install the exhaust ductwork to just below the roof. (In that case, you will have to finish installing the rest of the ductwork later, after the roofer has cut the roof opening.)

**NOTE**

Per NFPA 33, the air inlet hood on top of the intake stack and the automatic roof ventilator (ARV) on top of the exhaust stack must be at least 10 feet away from each other.

**NOTE**

To connect duct sections together:

- Slip the bottom of one duct section into the top of the previous duct section.
- Ensure that the duct section is level north-south and east-west.
- Tek-screw the duct section to the previous duct section from the inside out.

**Reference:** Refer to the diagram below and to the RH Side Elevation view on the GA page of the Design Drawings.

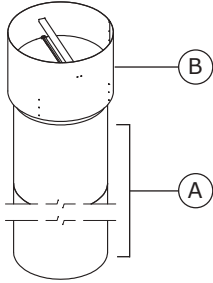

**A:** One or more sections of plain duct  
**B:** Automatic Roof Ventilator (ARV)

1. Confirm that a fan ring is bolted to the top of the exhaust fan.

**NOTE**

If the fan ring is not present, install it now as directed in .

2. Connect a section of plain duct to the fan ring.
  - a. Place a plain duct section over the duct lip of the fan ring.
  - b. Ensure that the duct section is level north-south and east-west.
  - c. Tek-screw the duct section to the duct lip from the inside out.
3. *If applicable:* Continue connecting all the necessary plain duct sections as required for the exhaust stack.

**NOTE**

Follow the procedure for connecting duct sections together in the notes at the beginning of this task.

4. Install the ARV:
  - a. Slip the bottom of the ARV over the top-most duct section.
  - b. Ensure that the ARV is level north-south and east-west.
  - c. Tek-screw the ARV to the duct section from the inside out.
5. Working down from the ARV to the exhaust fan, caulk the outside of all connections in the exhaust stack.

**NOTE**

Caulk all duct-to-duct connections and all assembly seams.

***If applicable: Install the guy-wire kit***

**NOTE**

Install the guy-wire kit per the instructions below. It is the responsibility of the customer or their agent (for example, a roofer or building contractor) to supply and install the cable tie-off points on the building roof (plate with ring). The diagram below is provided for reference only.

**NOTE**

Use #10 Tek screws to attach duct strap to exhaust duct; caulk to seal.

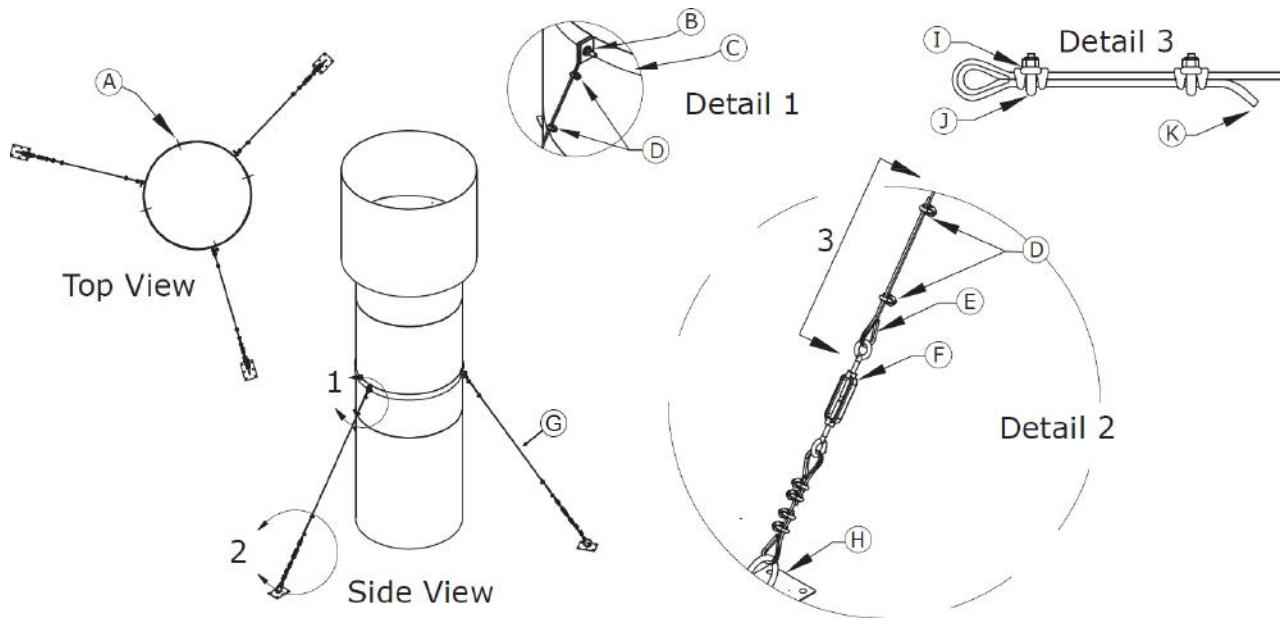

- A:** #10 Tek screw
- B:** For each connection, use one cable thimble; one 5/16-inch x 1-1/2-inch bolt; two 5/16-inch flat washers; one 5/16-inch lock washer; and one 5/16-inch nut.
- C:** Duct strap
- D:** Cable clamps (2)
- E:** Thimble
- F:** Turnbuckle
- G:** Cable; thimbles (2); cable clamps (4)
- H:** Plate with ring
- I:** Grip base
- J:** U-bolt (must have U-bolt over dead end of cable)
- K:** Dead end

## Install the lights

**Scope:** This step covers *only* the mechanical installation of the lighting fixtures and running the light cables through the roof to a junction box. A qualified electrician should wire the junction box to the air heater control panel as specified in “Perform electrical hookup” (page 53).

**Prerequisites:** The booth must already be assembled.

### References:

- Refer to the Light Fixture Installation instructions that ship with the light fixtures for instructions on installing the light fixtures into the panels.
- Refer to the Wire Harness page of the Design Drawings.
- For optional light accessories, refer to the following pages in the Design Drawings:
  - Reflector Light Fixture
  - Corner Light Harness
  - Corner Light Installation

## ***If applicable:* Install optional booth accessories**

**Scope:** This task applies only to booths that include optional accessories (for example, a parts hanger, tool cabinet, and so on).

**Prerequisites:** The booth lighting must already be installed as directed in “Install the lights” (page 45).

**References:**

- Refer to the appropriate Addendum page in the Design Drawings. (Addendum pages are numbered with an “A-” prefix.)
- Refer to the appropriate Wall Assembly page(s) in the Design Drawings for accessories that are incorporated into the wall panels, such as observation windows and rotating booth access tables.

## **Install the operator interface terminal**

**NOTE**

Ensure that the placement of all electrical devices meets the NEC requirements for clearance from combustible areas.

**Reference:** Refer to the HMI Installation page of the Design Drawings.

## Install miscellaneous electrical devices

### NOTE

Ensure that the placement of all electrical devices meets the NEC requirements for clearance from combustible areas.

### NOTE

This section provides instructions for installing miscellaneous electrical devices. As you install each device, retain any unused hardware. Place unused hardware in a bag and tape it to the device so that it will be available for the electrician.

## Install the temperature sensor

**Reference:** Refer to the following sections of the Temp Sensor & Diffuser/Baffle page of the Design Drawings:

- Temp Sensor Installation
- Side Discharge BT/GUL Air Heater

## Install the air-sensing tube

### NOTE

The high-pressure air-sensing pressure tip must be located on the same side of the booth as the control panel, at least 84 inches from the floor and at least 24 inches from any corner.

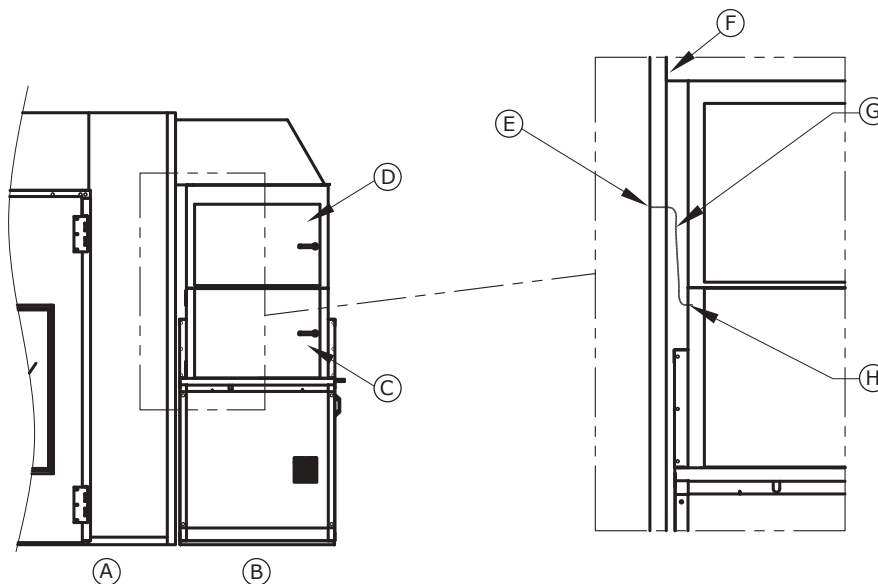

- A:** Booth (front view)
- B:** Air heater
- C:** Control panel door
- D:** Gas train access door
- E:** High-pressure air-sensing pressure tip
- F:** Booth sidewall
- G:** High-pressure air-sensing tube (AST)
- H:** Bulkhead fitting

1. Drill a 1/4-inch hole through the booth wall panel.

**NOTE**

The hole must be at least 84 inches from the floor and at least 24 inches from any corner.

2. Push the tubing through the wall.
3. Attach the high-pressure air-sensing tip and secure it to the inside of the booth wall.
4. Run tubing through the bulkhead fitting and attach it to the high-pressure fitting inside the control panel.
5. Attach a short tube (2-3 inches) to the low-pressure fitting inside the control panel.

***If applicable: Install the damper actuators***

**Scope:** This task applies only to a booth that uses a recirc air heater. If the booth uses a forced-dry air heater, skip this task.

**NOTE**

This task covers the mechanical installation of the damper actuators. An electrician will perform the wiring from the actuators to the control panel, as described in “Perform electrical hookup” (page 53).

**Reference:** Refer to the manufacturer's documentation that shipped with the damper actuators.



## Install the air solenoid valve

**Prerequisites:** The booth's air supply line must already be installed.

### NOTE

This task covers the installation of the directional valve in the compressed air line piping, and is usually performed by a plumber or mechanical contractor. An electrician will perform the wiring from the valve to the control panel, as described in "Perform electrical hookup" (page 53).

Install the air solenoid valve as close as possible to where the compressed air enters the booth, but no closer than 3 feet to any door or opening.

### NOTE

Refer to the following diagram to complete this task:

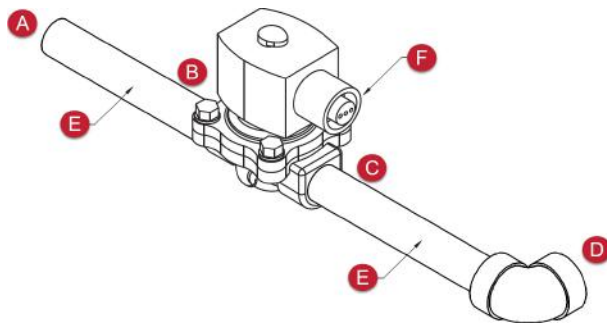

- A: From building air supply*
- B: Inlet*
- C: Outlet*
- D: Through booth wall*
- E: NPT pipe nipple (size will vary)*
- F: Conduit with wiring to control panel*

## Install the Economy Mode switch

**Prerequisites:** The booth's air supply line must already be installed.

### NOTE

The Economy Mode switch is standard on all auto refinish booths that have an air heater.

### NOTE

This task covers the installation of the switch in the compressed air line piping and is usually performed by a plumber or mechanical contractor.

### NOTE

Compressed air must be clean, filtered, and dry.

Connect the Economy Mode switch into the air line just before the air solenoid valve (i.e., between the air supply coming from the building and the air solenoid valve).

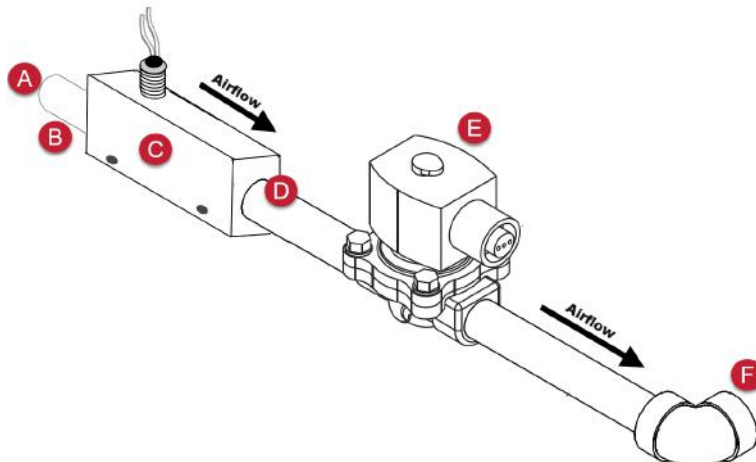

- A: From building air supply
- B: 1/2-inch NPT
- C: Economy Switch
- D: Outlet
- E: Air solenoid valve
- F: Through booth wall

### NOTE

Install the switch horizontally, with electrical to the top.

Figure 5. Economy Switch Installation (Thomas Products Model Number 1500)

## Install the air-proving switch

**Reference:** Refer to the instructions for the Airflow Switch Installation in the Electrical Drawings document.

### NOTE

For information on locating the Electrical Drawings document, refer to “Gathering required documentation” (page 14).

### ***If applicable: Install the puff switch***

**Scope:** This task applies only if the booth includes the GFS AdvanceCure System and the site purchased the optional puff switch with their booth.

**NOTE**

A puff switch is a switch located inside the booth that can be used to turn AdvanceCure on and off. It can be mounted anywhere on the inside of the booth. Mounting hardware and instructions are provided with the device.

## **Secure the wall panels to the floor profile**

**Reference:** Refer to the Floor Profile Tek-Screw Detail page of the Design Drawings.

## **Caulk the booth**

**Prerequisites:** The booth must already be assembled and anchored to the floor, and the booth lights must already be installed.

**Reference:** Refer to the Booth Caulking Guide page of the Design Drawings.

**IMPORTANT**

Do not caulk between fixed roof panels and explosion-relief panels. Caulking the explosion-relief panels will inhibit operation of the explosion-relief system. Refer to the Roof Panels page of the Design Drawings for details.

### ***If applicable: Install vehicle ramps and landing step***

**Scope:** This task applies only to a booth that uses a raised basement instead of a traditional pit.

**Reference:**

- For the vehicle ramps, refer to the Basement Ramp Assembly page of the Design Drawings.
- For the personnel landing step, refer to the Landing Step for Personnel Door page of the Design Drawings.

## **Prepare the air heater for startup**

1. Vacuum or sweep out the intake plenum and air heater (intake and exhaust side) to remove any debris that accumulated during installation.
2. *If necessary:* Install filters in the air heater.

**NOTE**

This step applies in cases where you removed air heater filters in order to complete installation steps, or in cases where the air heater filters have not yet been installed.

## ***If applicable: Install the curtain***

**Reference:** Refer to the Install Curtains page of the Design Drawings.

1. Hang the frontal curtains on their tracks.
2. If this is a drive-through booth, also hang the curtain at the rear of the booth.

## **Install booth filters**

**Prerequisites:** Ensure that you have completed all other tasks before installing the filters. (Waiting until the end of the procedure to install the filters helps ensure that the filters remain clean.)

### **Install the filter racks and intake filters**

#### **NOTE**

Perform this task for each filter rack.

1. Obtain a filter rack and place it on two sawhorses, with the flat side of the filter rack facing down.
2. Place the filter media on top of the filter rack, with the writing on the filter media facing down.
3. Use a filter-insertion tool (metal pizza cutter) to push the filter media into the slot all around the perimeter.

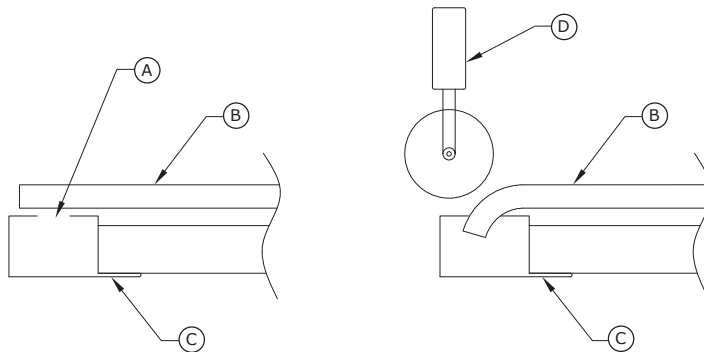

- A:** Slot in filter rack  
**B:** Filter media  
**C:** Filter rack  
**D:** Filter-insertion tool (metal pizza cutter)

4. Install the filter rack in the ceiling of the booth.

### **Install exhaust filter media in the pit or raised basement**

#### **NOTE**

This task assumes that the bar grating was placed in the pit or raised basement earlier in the procedure so that you could walk or drive over that area during the installation procedure.

#### **Reference:**

- If the booth has a traditional pit: Refer to the Pit Assembly page of the Design Drawings.

- If the booth uses a raised basement: Refer to the Basement “x.2” page of the Design Drawings.

1. Remove the bar grating from the pit or raised basement and set it aside.

**WARNING**

Do not walk or drive over the pit or basement while the bar grating is removed.

2. Sweep and vacuum out any dirt or debris that fell into the tunnel and pit (or raised basement) during installation.
3. Place the diffuser trays in the pit or raised basement.
4. Place the wire grid above each row of diffuser trays.
5. Place the filter media in the pit or raised basement:
  - a. Obtain a roll of filter media.
  - b. Place the roll at one end of a pit row with the **air leaving side of the filter media facing down**; then roll out the filter media along the length of the pit.
  - c. Cut off the excess filter media when you reach the opposite end of the pit.
6. **If the pit or raised basement has more than one row:** Repeat step 5 to place filter media in each additional row.
7. Replace the bar grating on top of the pit or raised basement.

**NOTE**

Grating must be installed with cross rods on top.

**NOTE**

You can walk and drive over the pit or raised basement after the bar grating is installed.

**WARNING**

**Fall Hazard:** Do not drive over the bar grating in a vehicle that exceeds the maximum wheel load listed in the Bar Grating Specification table on the Pit Details page of the Design Drawings.

## Perform electrical hookup

**WARNING**

Electrical installation should be completed by a qualified electrician. Installation must meet all applicable national, state, and local electrical codes.

**Reference:** Refer to the Electrical Drawings while completing this task.

**NOTE**

For information on locating the Electrical Drawings document, refer to “Gathering required documentation” (page 14).

1. Connect the building’s Main Power supply to the air heater control panel.

**NOTE**

Refer to electrical data plate for electrical requirements.

**WARNING**

Do not energize until you are ready to test motor rotation during commissioning and startup (see “Perform commissioning and startup” (page 55)).

2. Complete the wiring from these motors to the air heater control panel:
  - Air heater intake motors
  - Exhaust motors
  - *If applicable*: AdvanceCure fan motors
3. Wire the lights from the junction box to the air heater control panel.

**NOTE**

Lights have five conductor cables:

- Black (hot) and white (neutral): Power
  - Orange and red: Proximity switches
  - Green: Ground
4. Wire the proximity switches on product doors and personnel doors to the air heater control panel.

**NOTE**

Proximity switch wire colors are:

- Brown: Hot
  - Black: Signal
  - Blue: Common
5. Wire these electrical devices to the air heater control panel:
    - **Operator interface terminal**: Wire from terminal to control panel.
    - **Temperature sensor**: Wire from probe to control panel.
    - *If applicable*: **Damper actuators**: Wire from actuator to control panel.
    - **Air solenoid valve**: Wire from valve to control panel.
    - **Economy valve** (aka Economy Mode switch): Wire from valve to control panel.
    - *If applicable*: **Puff switch** (in-booth on/off switch for AdvanceCure): Wire from switch to control panel.

# Perform commissioning and startup

## **Prerequisites:**

- The booth must be fully assembled and caulked.
- Intake filters and the exhaust filter media must already be installed.
- The air heater must have been vacuumed or swept out, and the air heater filters must already be installed.
- An electrician must have completed the electrical hookup.

## **NOTE**

A trained GFS Distributor usually performs booth startup. The person who performs booth startup is responsible for completing the Final Commissioning Document and returning a signed copy to GFS.

**Reference:** Refer to the Final Commissioning Document. (For information on locating the Final Commissioning Document, see “Gathering required documentation” (page 14).)