



GLOBAL
FINISHING
SOLUTIONS



Ultra[®] CTOF Downdraft Booth with SpaceSaver[®] Air Heater (Dual-Bay)

Installation Manual

Document Number: 239-147 rev 1

Publication date 03/28/2024

Read and keep this manual for future reference. All personnel operating the equipment described in this manual should review and understand all instructions before use.

Table of Contents

Introduction	3
About Global Finishing Solutions LLC	3
Contacting Global Finishing Solutions	3
Target audience	3
Conventions used in this manual	4
Safety notices	4
Information notices	4
General safety	5
Booth safety	8
Booth description	11
Preparing for installation	12
Accepting delivery of your booth	12
Gathering required documentation	13
Confirming site requirements	14
Confirming booth layout	14
About the Design Drawings document	16
Page elements	16
Page types	18
Required materials	20
Required tools	20
Recommended equipment	21
Installation best practices	22
Unpack in stages	22
Sort parts by size	23
Remove protective coating	23
Follow assembly guidelines	24
Installation procedure	25
Booth installation sequence	25
Perform commissioning and startup	28

Introduction

About Global Finishing Solutions LLC

Leading the Industry in Paint Booth and Finishing System Technology

With decades of experience, Global Finishing Solutions is the leading manufacturer of paint booths and finishing systems for many industries, including automotive refinish, aerospace and defense, industrial manufacturing, woodworking, and large equipment. By combining high-quality components, strong relationships with paint manufacturers, and our experienced distribution network, GFS provides the best equipment and support to set your business up for success.

Contacting Global Finishing Solutions

General information

- Toll-free: 800-848-8738
- Fax: 715-597-2193
- Email: info@globalfinishing.com
- Online: www.globalfinishing.com

Technical support

- Toll-free: 800-848-8738
- Fax: 715-597-8818
- Email: techservices@globalfinishing.com

Parts and filters

- Toll-free: 800-848-8738
- Fax: 888-338-4584
- Email: parts@globalfinishing.com

Target audience

This document is intended for use by trained, experienced paint booth installers and maintenance technicians. If you have questions about the installation procedure described in this manual, contact GFS as described above.

Conventions used in this manual

This section describes how information is presented, organized, and referenced within this manual.

Safety notices

This manual uses the following standards to identify conditions related to safety hazards and equipment damage.

Table 1. Safety notices

Symbol	Description
DANGER	Indicates an imminent hazard that will result in death.
WARNING	Indicates a hazard that can result in serious personal injury or death.
CAUTION	Indicates a hazard that can result in personal injury.
NOTICE	Indicates a situation that can result in equipment or property damage, but poses no risk of personal injury.

Information notices

In addition to the safety notices described above, this manual uses a boldface keyword to identify certain other types of information.

Table 2. Information notices

Keyword	Description
NOTE	Denotes general information that provides additional context or guidance.
Important	Denotes information to which you should pay special attention.
Reference	Directs you to related content in a separate document.
Prerequisites	Specifies other tasks that must be completed or conditions that must exist before you perform the current task.
Scope	Describes limitations to the current task or conditions under which the task applies or does not apply to the procedure.

General safety

Follow all safety guidelines when assembling, operating, or servicing this product.

WARNING

There are inherent hazards associated with the operation and service of this equipment. For your personal safety, observe all safety information. Failure to observe these safety practices can result in personal injury or death.

WARNING

Operation and maintenance of this product must be performed properly by qualified personnel who observe the warnings in all documentation and notes provided with and on the product.

WARNING

Follow all general standards for installation and safety for work on installations. Follow all good practices for the proper use of lifting tackle and equipment. The use of protective equipment such as safety goggles and protective footwear must be considered.

WARNING

All persons who will operate, service, inspect, or otherwise handle this product must read and understand the safe operating practices, safety precautions, and warning messages in this documentation.

WARNING

The roofs of GFS equipment are not designed or intended to be walked upon or to support weight of any kind. As designed and manufactured, equipment roofs do not meet the minimum requirements of a safe walking and/or working surface under OSHA 1910.22. Under no circumstances should the roof be used by maintenance personnel or others for walking, standing, or storage of any kind. When necessary, roof access should be secured through the use of a properly supported platform that satisfies the minimum load requirements specified by ASCE 7 (Minimum Design Loads and Associated Criteria for Buildings and Other Structures) and ASCE 37 (Design Loads on Structures during Construction). Additionally, personnel should always utilize appropriate fall safety protocols when using an elevated platform. Use of the roof in a contrary manner may result in injury and/or death.

WARNING

Comply with OSHA guidelines and with all applicable local electrical, safety, and fire codes and standards.

WARNING

All field wiring provided must comply with local codes or, in the absence of local codes, the National Electrical Code (NFPA 70). Article 516 covers applicable of flammable and combustible materials.

WARNING

Electrical installation should be completed by a qualified electrician. Installation must meet all applicable national, state, and local electrical codes.

WARNING

Ensure that all electrical components are grounded to a central ground.

WARNING

Disconnect and lock out the main electrical service before installing, adjusting, or servicing the product.

WARNING

Lockout the main gas shutoff valve before maintenance or inspection of the air heater.

WARNING

Guards and covers that prevent contact with electrically energized or moving parts are required and must not be removed or left open during operation.

WARNING

Welding, cutting, and other spark-producing operations shall not be permitted in or adjacent to a booth until a written permit authorizing such work has been issued. The permit shall be issued by a person in authority following his or her inspection of the area to ensure that precautions have been taken and will be followed until the job is completed.

WARNING

Local fire and building codes require fire protection. Check with local inspector authorities for requirements.

CAUTION

Read and save these instructions before attempting to assemble, install, operate, or maintain the product described. Protect yourself and others by observing all safety information. Failure to comply with instructions could result in personal injury and/or property damage. Retain these instructions for future reference.

CAUTION

This manual contains statements that relate to worker safety. Read this manual thoroughly and comply as directed. Operate this equipment in accordance with the guidelines set forth in this manual. It is impossible to list all potential hazards of this equipment. Instruct all personnel involved with this equipment in the safe conduct and operation of the system. GFS recommends that only qualified personnel operate and maintain this equipment.

CAUTION

Safety signs, panels, and labels that are normally affixed to the product must be replaced immediately if illegible or missing.

CAUTION

New or replacement parts that are installed during repair or maintenance must include all safety signs, panels, and labels as specified by the manufacturer. These must be affixed to the new or replacement parts as specified by the manufacturer.

CAUTION

Where applicable, use earplugs or take other safety measures for hearing protection.

NOTICE

The product must be installed and serviced only by a trained, qualified service technician. Incorrect installation may void the warranty.

NOTICE

If you have questions about the warranty, please contact your distributor prior to contacting GFS.

Booth safety

DANGER

Ceiling panel load capacity for installation and maintenance: You must use temporary platforms that span at least two structural frames for maintenance. **Do not walk on or apply any pressure to lights or explosion (deflagration) relief panels.**

WARNING

All equipment must be operated and maintained in accordance with local, state, and federal (OSHA) requirements governing occupational safety, fire protection, and booth operations. Operators must read and understand GFS and included independent equipment and/or component manufacturer's instructions prior to use. **Disclaimer:** GFS is not responsible for any injury, illness, or property damage that results from not abiding by local, state, or federal (OSHA) requirements that govern occupational safety, fire protection, and booth operations. GFS is also not responsible for any injury, illness, or property damage that is the result of not adhering to GFS and/or independent equipment/component operating, service, maintenance, and/or installation requirement's or directives.

WARNING

Install the booth in compliance with locally enforced codes and standards.

WARNING

A fire suppression system is required by the International Fire Code and NFPA 33. A fire suppression system is not supplied with this booth.

WARNING

Do not allow overspray to accumulate on the inside of the paint booth walls. When overspray accumulates, remove it as soon as possible to prevent a possible fire hazard. Use a non-ferrous, non-sparking scraper to eliminate any possibilities of igniting combustible material.

WARNING

Do not leave piles of paint sweepings in the booth as it creates a possible fire hazard.

WARNING

Treat used filters and any other paint-contaminated items as flammable products and dispose of them safely.

WARNING

If coatings containing nitrocellulose are sprayed in the booth, all residue must be removed from exhaust diffuser components and all exhaust filters must be changed at least once a day.

WARNING

Improper disposal of used filters may cause spontaneous combustion. You must consult local authorities for proper storage and disposal requirements. Guidelines include:

- Immediately remove all contaminated filters from the paint booth.
- Discard filters to a safe, detached location, place them in a non-combustible container with tight-fitting lid, or place them in a water-filled metal container to prevent a possible fire hazard.
- Disposal varies depending on the type of paint that is being captured. Consult local authorities for storage and disposal requirements.

WARNING

Duct the exhaust air from the fan away from the working environment to the outdoors. Do not operate the booth unless exhaust has been ducted properly.

WARNING

Isolate the outdoor vent from air-conditioning intakes, windows, and any other equipment that may recirculate the exhaust indoors.

WARNING

Turn on the exhaust fan before using the booth. Ensure that the exhaust fan is operating correctly before entering the booth.

WARNING

Check local codes to see if a booth interlock is required. A booth interlock prevents the spray devices from operating unless the exhaust fan is operating.

WARNING

Some spray activities may require the use of respiratory protection.

WARNING

Use an OSHA-approved paint spray respirator when spraying in the booth.

WARNING

This equipment is designed for the removal of particulate matter only. Reduction of volatile organic compounds (VOCs) requires either coating reformulation or optional, additional equipment.

WARNING

Fall Hazard: Do not walk or drive over the pit without the bar grating in place.

WARNING

Fall Hazard: Do not drive over the bar grating in a vehicle that exceeds the maximum wheel load listed in the Bar Grating Specification table on the Pit Details page of the Design Drawings.

WARNING

Fall Hazard: Do not remove bar grating from the pit unless authorized to do so. The pit presents a fall hazard when the bar grating is not installed.

CAUTION

Become familiar with all controls before operating or servicing this booth.

CAUTION

Proper door alignment is critical to the operation of the booth. Ensure that there is equal space around the doors. Move the bottom of the door jamb to the left or right or in and out until the doors are sealed and plumb.

CAUTION

If this installation includes pumps or compressors, install and connect those devices in accordance with the manufacturer's documentation.

NOTICE

GFS recommends storing crates indoors pending installation. If you must store crates outside, protect crates and their contents from moisture to prevent damage to equipment.

NOTICE

Install the control panel per NFPA 70 and local codes and standards.

NOTICE

Failure to anchor the booth structure to the floor properly may result in structural damage.

NOTICE

GFS does not provide materials for constructing the pit. It is up to the customer to arrange for the actual construction of the pit.

Booth description

GFS' Ultra Closed-Top Open-Front (CTOF) Booth line provides a versatile, end-to-end finishing environment that allows vehicles to be filled, primed, sealed, painted, and cured in one location.

Generally accepted as the best airflow style, downdraft booths do an excellent job controlling overspray and contamination. Air enters the booth through a filtered ceiling plenum, flows vertically over the product, and into the filtered exhaust pit in the floor.

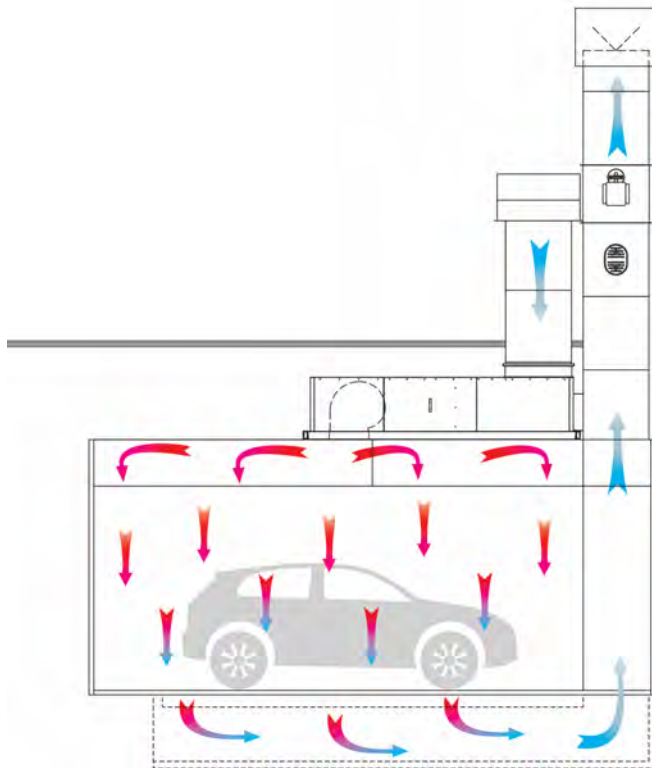

Figure 1. Airflow in a downdraft booth with a SpaceSaver air heater

Preparing for installation

Accepting delivery of your booth

The booth is delivered unassembled, in multiple crates.

Upon delivery, count the number of crates you received and compare that number to the expected number per the Bill of Lading. Also inspect each crate for any signs of damage during shipment.

NOTE

If you see shipping damage, note it on the freight carrier's paperwork; failure to do so may result in claim denial.

If any parts are missing or damaged, contact Global Finishing Solutions at 800-848-8738 to speak to a Technical Service Representative.

NOTICE

GFS recommends storing crates indoors pending installation. If you must store crates outside, protect crates and their contents from moisture to prevent damage to equipment.

Gathering required documentation

Ensure that you can locate these documents and that they are available during the installation procedure.

NOTE

Certain manuals, project drawings, and the Job-Specific Guide are also provided electronically to distributors via box.com. Many manuals are available for download on globalfinishing.com.

Table 3. Additional documentation

Document	Description	How provided
Design Drawings	Provides instructions for assembling this particular booth and includes information about the booth order, configuration, and components.	Ships in the “Miscellaneous” box
Electrical Drawings	Provides wiring diagrams for electrical components.	Ships inside the air heater control panel
Control Panel Operator Manual	Setup and operation instructions for the appropriate control panel: <ul style="list-style-type: none"> • Engage® Control Panel Operator Manual • LOGIC 3 Control Panel Operator Manual • LOGIC 4 Control Panel Operator Manual 	Ships inside the air heater control panel
<i>If applicable:</i> Air heater owner’s manual	Installation, operation, and maintenance instructions for the air heater; either: <ul style="list-style-type: none"> • GUL/BT Series Owner’s Manual (for GUL and BT air heaters) • SpaceSaver® Series Owner’s Manual 	Ships inside the air heater control panel
Final Commissioning Document (D0420)	Includes all tasks related to booth startup and commissioning.	Ships inside the air heater control panel

Confirming site requirements

Before beginning the installation procedure, confirm that the site where the equipment will be assembled meets the following requirements:

- The floor where you will assemble the paint booth is level.

NOTE

If the floor is more than 1 inch out of level, you must shim or grout the floor to avoid any misalignment.

- The area is large enough to allow a minimum of 3 feet (914 mm) of clear space on all four sides of the booth, taking into account if additional space is needed for an air heater or Air Make-Up Unit. Check local codes and refer to NFPA guidelines to determine particular space allowances.
- There is sufficient overhead clearance for an exhaust unit and the exhaust ductwork in the area where the equipment is to be located.
- A licensed electrician has verified that the incoming power meets the requirements specified for the equipment. (The power specification is included with the submittal or provided at delivery.)
- The appropriate devices for lifting/rigging are available onsite. (Either purchased from GFS with the booth, or obtained elsewhere by the customer.)
- The appropriate miscellaneous hardware kits are available on-site. (Either purchased from GFS with the equipment, or obtained elsewhere by the customer.)

Confirming booth layout

Before beginning the installation procedure, review the booth configuration and layout with the end user. Be sure you understand what options this booth includes and how the end user wants to arrange the booth.

The GA page of the Design Drawings shows one *possible* booth layout. However, end users might want their booths arranged differently. **During installation, you must make the appropriate adjustments to the instructions to accommodate the actual booth layout.**

For best results, review the GA page of the Design Drawings drawing with the end user and discuss the items listed below:

- Is this booth a drive-through booth (a booth with a product door or curtain on each end) or a solid-back booth?
- For a drive-through booth:
 - Does the front of the booth have a frontal curtain or 3-slab product door?
 - Does the rear of the booth have a curtain or 3-slab product door?
- Where does the end user want to locate the personnel door?
 - On the left or right side of booth?
 - At which panel position?
- Where does the end user want to place the operator interface terminal/HMI?

NOTE

Per NEC, the operator interface terminal cannot be located within 3 feet of any door opening. Refer to the HMI Installation page of the Design Drawings for more information about placement restrictions.

- On an exterior booth wall? (If so, specify which.)
- On a nearby wall? (If so, determine distance and orientation relative to booth.)
- *If applicable*: Within the booth's interior, how does the end user want to arrange the wall lights?
- If the booth includes standard options and accessories, where should those items be located? (Examples include additional light fixtures, rotating access tables, observation windows, parts hangers, additional personnel doors, etc.)

About the Design Drawings document

Use this manual in conjunction with the provided Design Drawings document. This Design Drawings document defines the overall layout and detailed structure of your particular booth. If applicable, it also includes exploded-view diagrams and parts lists for each section (or subassembly) of the booth.

Page elements

Pages within the Design Drawings document contain the following elements:

- **Title block:** The title block is located along the right edge of each page. It contains the model information, drawing identification label or number, the order/serial number, and other information.
- **Model Info:** Contains text that identifies each page within the Design Drawings document, e.g., "Overall Assembly". When the installation instructions refer you to a specific page within the Design Drawings, look for that text in the Model Info field. (For a description of the various page types that might be included in your Design Drawings document, see Page types.)
- **Scale:** If the drawing is to scale, the scale is defined here (e.g., 3/16" = 1' 0"). Otherwise, this field contains "NTS," or "Not to Scale."
- **Drawings:** The main area of each page can contain any or all of these types of drawings:
 - An exploded and/or assembled view of the product or subassembly
 - Additional views or "Detail" drawings
- **Bill of Materials:** Any page that includes a drawing with labeled parts also includes a table that lists each item number with its corresponding part number and quantity.
- **Quantity per Booth:** Pages that show a subassembly of the product and list the quantity provided of that particular subassembly.
- **Notes:** Pages within the Design Drawings often contain notes that provide information about how to install that particular section or subassembly.

About the Design Drawings document

NOTE:

- USE 80% HANDICAPER FREE PANEL TO PANEL CONNECTION.
- APPLY ADHESIVE FOAM (FOAM GUSSET) TO BOOTH TOP EDGE OF ALL H-CCHANNELS.
- USE 80% HANDICAPER FREE PANEL TO WALL CONNECTION.
- TRIM CORNER COVERS TO MATCH BOOTH HEIGHT.
- USE TRIM SCREENS (SS-4375) TO ATTACH BOOTH CORNER COVERS.

H-CCHANNEL INSTALLATION DETAIL VIEW

WALL PANEL SPACING IS IMPORTANT. INCORRECT SPACING WILL CAUSE THE HOLES TO ALIGNMENT PROBLEMS TO BECOME MISALIGNING. CAUSE THE WALL TO BUMP OR BUCKLE OR CAUSE THE WALL TO BUCKLE LOWER ALONG THE TOP THAN THE BOTTOM. FOR REFERENCE, THESE SHOULD BE 1/8" BETWEEN EACH CASE BUT HOLES FUNCTIONED IN THE TOP OF THE PANEL.

PLENUM PANEL / WALL PANEL CONNECTION

WALL PANEL TO COLUMN CONNECTION DETAIL

WALL PANEL INSTALLATION DETAIL BETWEEN TUBE COLUMN

SEE 80% PERSONNEL LOCK INSTALL POINT

WALL AND PLENUM PANELS ARE FLUSH TO THE OUTSIDE OF THE BOOTH

WALL PANEL TO COLUMN CONNECTION DETAIL

QUANTITY PER BOOTH:

TOTAL QUANTITY:

NO.	QTY	DESCRIPTION	UNIT
39	1	80% PERSONNEL LOCK	
40	7	H-CCHANNEL, 107.845	28 WP
41	2	H-CCHANNEL, 23.500	24 WP
42	3	PANEL ASSEMBLY, DUAL SKIN, 1.50HT	
43	2	PANEL ASSEMBLY, DUAL SKIN, SOLID	
44	4	PANEL ASSEMBLY, DUAL SKIN, SOLID	
45	1	PANEL ASSEMBLY, DUAL SKIN, SOLID	
46	5	PANEL ASSEMBLY, SINGLE SKIN, FLENUM	
47	2	PANEL ASSEMBLY, SINGLE SKIN, FLENUM	

GLOBAL FINISHING SOLUTIONS
 800-848-8728
 8550 W. WISCONSIN AVE
 OSSAHO, WI 53758 USA
 globalfinishing.com

DATE: 2/17/2019
BY: [Signature]
DATE: 2/28/2019
REVISED BY: [Signature]
DATE: [Signature]

PROJECT INFO:
 CA-WMS-270-DUP-3L-R-F
 SIDE WALL, 27' L X 9' H

DRAWING SET: R01

DATE: 2/17/2019

SCALE: 1/8" = 1'-0"

PROJECT NO.: UXXXXXXXX

DATE: 2/17/2019

SCALE: 1/8" = 1'-0"

PROJECT NO.: UXXXXXXXX

DATE: 2/17/2019

SCALE: 1/8" = 1'-0"

PROJECT NO.: UXXXXXXXX

- A:** Serial number
- B:** Model info
- C:** Drawing number
- D:** Drawings: Main view (exploded and/or assembled)
- E:** Drawings: Detail view
- F:** Bill of materials
- G:** Quantity per booth
- H:** Notes
- I:** Title block

Page types

The Design Drawings document may contain any of the following pages that apply to your particular product.

Table 4. Page names in the Design Drawings document

Page name	Description
AdvanceCure	Provides instructions for installing the optional GFS AdvanceCure System. NOTE This page applies only to booths that include AdvanceCure.
AdvanceCure Intake & Discharge Cover Kit	Shows how to install cover plates at locations where the optional GFS AdvanceCure System integrates with the booth. NOTE This page applies only to booths that do not include the AdvanceCure.
Air Heater	Provides instructions for assembling the air heater.
Air Inlet Hood	Shows how to assemble the air inlet hood that goes on top of the intake stack.
Basement	Shows how to install a raised basement for a downdraft booth. NOTE A raised basement can be used in place of a traditional exhaust pit.
Basement Ramp Assembly	Shows how to assemble vehicle ramps. NOTE This page applies only to downdraft booths that use a raised basement instead of a traditional pit.
Booth Caulking Guide	Provides instructions for applying caulk to the booth.
Corner Light Harness	Shows how to run the wire harness cables to the optional corner light from the control panel.
Corner Light Installation	Shows how to install optional corner lights.
Door Frame	Shows how to install a product door frame. NOTE A Door Frame page is classified as “3 Slab Door” or “4 Slab Door,” depending on the type of product door that will be installed in that frame.
Door Slab	Shows how to install a product door and its associated hardware. NOTE A Door Slab page is classified as “3 Doors” or “4 Doors,” depending on how many door slabs comprise that product door.
Filter Ceiling	Shows how to install the filter ceiling and roof supports.
Floor Profile	Shows how to install the floor channel and floor-leveling components; also specifies where to place the rear-most columns for the air heater frame.
Floor Profile Tek-Screw Detail	Shows how to secure the wall panels to the floor profile.
Front Wall	Shows an exploded view of a drive-through end wall (a wall that accepts a product door). NOTE A Front Wall assembly is always installed at the front of the booth. For drive-through booths (which have a product door at each end), a Front Wall assembly is <i>also</i> installed at the rear of the booth. NOTE A Front Wall page is classified as “3 Slab Door” or “4 Slab Door,” depending on the type of product door that will be installed at that end.

Page name	Description
GA	<p>Provides a top view of the booth as well as front, side, and rear elevations.</p> <p>NOTE The GA page shows the standard booth arrangement and is provided for reference only; it is <i>not</i> customized for the booth you are building.</p> <p>NOTE The actual placement of some components (such as the air heater, personnel door, wall lights, etc.) might be different than shown on this page. Always consult with the end user for placement details, as described in “Confirming booth layout” (page 14).</p>
Hip Panels	Shows how to install the hip light panels.
HMI Installation	Provides instructions for installing the operator interface terminal.
Install Curtains	Shows how to install curtain mounting tracks.
Locking Rod	Shows how to install the locking rod assembly for product doors.
Label Placement Instructions	Shows where to place various booth labels, including exit, maintenance, and safety labels.
Light Fixture Details	Shows how to install booth lights.
Overall Assembly	Shows an exploded view of the entire booth; identifies the major components and sub-assemblies of the booth.
Personnel Door	Shows how to install a personnel door and its associated hardware.
Pit Assembly	Shows how to install diffuser trays, filter media, and bar gratings in the exhaust pit of a booth.
Pit Details	<p>Provides instructions for constructing the exhaust pit for a booth.</p> <p>NOTE End users are responsible for constructing the pit prior to booth installation.</p> <p>NOTE On the Pit Details page, the title block’s Drawing field contains the word “Pit” instead of a sequential sheet number.</p>
Rear Wall	<p>Shows an exploded view of a solid end wall.</p> <p>NOTE This page applies only to booths that are not drive-through booths.</p>
Recirc Duct Assembly	Shows how to assemble and install the ductwork that goes between a recirc air heater and the exhaust yoke.
Reflector Light Fixture	Shows how to install the optional light-reflector kit.
Roof Panels	Shows how to install the roof panels.
Roof Support Assembly	Shows how to install the roof support assembly.
Side Wall	<p>Shows an exploded view of a side wall.</p> <p>NOTE The Design Drawings always contains two Side Wall pages: one that includes a personnel door, and one that does not include a door.</p>
Structural Frame Assembly	Provides instructions for installing the booth frame.
SpaceSaver Install	Provides instructions for mounting a SpaceSaver air heater on its frame.
Structural Frame Assembly	Provides instructions for installing the SpaceSaver structural support frame, columns, and trusses.
Temp Sensor & Diffuser/Baffle	Provides instructions for installing the temperature sensor and a diffuser (for an air heater with side-discharge into the booth) or a baffle (for an air heater with down-discharge into the booth).
Wire Harness	Shows how to run the wire harness cables for the lights to the air heater control panel.

Required materials

This section lists the tools, equipment, and documentation required for installing your booth.

NOTE

Depending on the type of equipment you are installing, additional tools may be required.

Required tools

- Screwdrivers
- Wrenches and socket set
- Hammer and mallet
- Load bar that can extend to at least 9 feet (108 inches)
- Filter-insertion tool (metal pizza cutter; approximately 3-inch to 4-inch diameter)
- Drift pins (two per person; 1/8-inch to 5/8-inch taper)
- Caulk gun
- Impact driver and drill
- Unibit or step drill bits
- Chalk and/or felt-tip marker (for marking initial measurements on floor)
- Chalk-line tool
- 4-foot box level
- Laser level (*Suggested:* Quad laser or rotary laser level)
- Tape measures (35-foot and 100-foot)
- Tin snips
- Duct crimping tool
- Torque nut runner
- Reciprocating saw
- *Optional:* Torch and welder in case modifications need to be made on site
- Tools required for decal placement:
 - Stiff squeegee
 - Spray bottle with soapy-water mixture
 - Paper towels
 - Scissors
 - Masking tape
 - Marker

Recommended equipment

- Ladders (6-foot and 8-foot)
- Two or more sawhorses
- Two 26-foot T scissor-lift platforms
- Warehouse forklift with 5000-pound lift weight and a maximum lift height higher than 16 feet

NOTE

Lifts and cranes are not required, but they may improve both the safety and speed of installation.

NOTE

The end user is responsible for providing any lifts, cranes, and material handlers. Alternatively, the end user can coordinate with the installer so the installer can rent those items before starting the work.

Installation best practices

Unpack in stages

As you begin each section of the installation procedure, unpack the crate(s) that contain the parts for that section. In general, the skids are organized so the parts that go together during assembly are packed on the same skid.

NOTE

For faster unpacking, use a reciprocating saw to cut the crates.



Figure 2. Skids awaiting unpacking

A packing list is attached to each crate. As you unpack a crate, compare all the parts with that crate's packing list to check for shortages or losses in transit. Also check parts for any damage that might have been caused in shipping.

NOTE

Slightly bent panels and angle braces can be straightened and will cause no performance or assembly problems.

If any parts are missing or damaged, contact Global Finishing Solutions at 800-848-8738 to speak to a Technical Service Representative.

Sort parts by size

To help installation proceed more efficiently, sort all parts by size as you unpack them (Figure 3).

Each part has a specific part number. The part number is either etched into the part or printed on a label affixed to the part (Figure 4).



Figure 3. Panels sorted by size in preparation for assembly

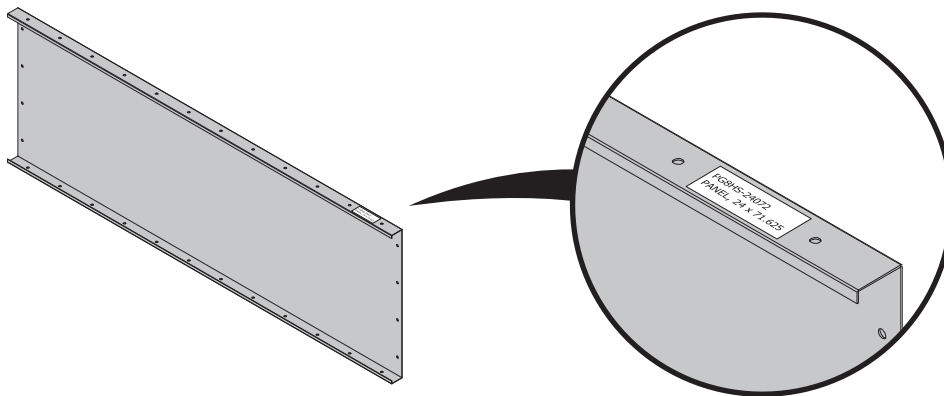

Figure 4. Example of a part number label

Remove protective coating

Some booth parts ship with a protective coating. For efficiency during installation:

- Remove the part number label from the part and set the label aside temporarily.
- Remove the blue protective coating from the part.
- Re-apply the part number label on the part. (Use tape to affix the label to the part, if necessary.)

Follow assembly guidelines

Follow these guidelines when assembling the booth:

- Assemble the booth in sections, following the sequence provided in this document.
- As you build each section, tighten the bolts only to finger-tight.
- Before tightening the bolts within a section, confirm that the section is plumb and square.
- When directed to do so, tighten the bolts within a section to *snug-tight*. Snug-tight is defined as “the tightness that is attained with a few impacts of an impact wrench or the full effort of an ironworker using an ordinary spud wrench to bring the plies into firm contact.” (RCSC 2014)
- **For dual-skin booths:** Orient panels and parts as shown on the assembly drawings.
- **For single-skin booths:** Orient panels so that each panel’s flanged side faces outward, and the non-flanged side faces the booth’s interior.
- **For all booths:** When applicable, orient bolts so that the bolt heads (and a washer) are on the booth’s interior and the threads are on the exterior.
- Use hardware as specified on the assembly drawings.
- Plumb the panels so that they are perpendicular to the floor. The sides of the booth must be parallel to each other.

Installation procedure

This procedure describes how to install a dual-bay Ultra XD or XS CTOF downdraft booth with a SpaceSaver air heater.

Booth installation sequence

Reference: Refer to the Design Drawings to complete the installation sequence outlined below:

1. Safeguard the pit:
 - a. **For a 2-row or 3-row pit:** Install the pit supports.
 - b. Place the bar grating over the pit.
 - c. Cover the airflow openings with plywood and mark them as holes so no one will drive over them.
2. Prepare the floor and mark the booth footprint with chalk lines.
 - If the floor is out of level by **1 inch or less** over the full length of the booth, continue to the next step. (You do not need to take any corrective action now because you will be able to correct for slope when you install the floor leveling components later in the procedure.)
 - If the floor is **more than 1 inch** out of level over the full length of the booth, shim or grout the floor as needed to get it within 1 inch of level. GFS does not provide shims.
3. Mark and position the six columns for the air heater support frame. Each column will be secured to the floor with two expansion anchors.

NOTE

Do not anchor the columns until the trusses are installed.

NOTE

GFS does not supply the anchors

NOTE

Position the two rear columns first, then the two middle columns, and then the two front columns.

4. Install a truss between the two rear-most columns. Shim and grout the columns as necessary.

NOTE

This truss will have cover skins. Install the truss cover skins on the truss prior to attaching it to the columns.

5. Install a truss between the two middle columns. Shim and grout the columns as necessary.

NOTE

This truss will not have cover skins.

6. Assemble the SpaceSaver air heater on the floor.
7. Mount the air heater on the trusses.
8. Install the floor channel:

- a. Install the floor outer profiles.

NOTE

Do not install floor profiles at the curtain or product door location(s).

- b. Anchor the floor outer profiles to the building floor.
- c. Install and level the panel leveling profiles.
9. Build the rear exhaust yoke and attach to the back side of the rear truss.
10. Install the rear wall panels.
11. Install a truss between the two front-most columns. Shim and grout the columns as necessary.

NOTE

This truss will have cover skins. Install the truss cover skins on the truss prior to attaching it to the columns.

12. Build the front wall of the booth.

NOTE

Affix the branding decal to the header panel prior to installation. If there is more than one header panel, the branding decal should be located on the right-hand side of the right-most panel when you are looking at the front of the booth.

13. Install the side wall panels:
 - a. On the left or right side of the booth, install the vertical panels. Start at the exhaust yoke and work toward the front of the booth.
 - b. Install the plenum panels on top of the vertical panels.
 - c. Repeat step a through step b to install the other side wall of the booth.
 - d. Ensure that the side walls are plumb, square, and level.

14. Install the exhaust fan.

Place two pieces of duct before the fan. It may be necessary to place the fan outside if there is not sufficient space behind the booth.

15. Assemble and install the intake and exhaust stack up to roof height.

16. Install the roof panels.

Begin installing the panels adjacent to the air heater, then work toward the front of the booth.

17. *If applicable:* Install the GFS AdvanceCure[®] motor boxes and motors.

NOTE

Do not wire.

18. Install the damper and recirc duct assembly to the heater.
19. Secure recirc duct to the top of the exhaust yoke.
20. Install the hip light panels:
 - a. Attach the side light panels and mounting brackets.
 - b. Attach the center light panels and mounting brackets.
21. Install the filter ceiling panels.

NOTE

Do not install the filter racks or the intake filters during this step.

NOTE

If the booth does not include the optional AdvanceCure system, install the GFS AdvanceCure cover kit.

22. *If applicable:* Install intake and discharge AdvanceCure ductwork.
23. *If applicable:* Install all AdvanceCure towers.
24. Install the discharge plenum diffuser.
25. Install the light fixtures and light cables.
26. Install the personnel door(s).
27. Install the product door frame(s).
28. *If applicable:* Install the track and brackets for the frontal curtains.

NOTE

Install the track and brackets for the frontal curtains.

29. *If applicable:* Install the product door(s):
 - a. Install the outer hinges and locking rods.
 - b. Place the door hardware on the door slabs.
 - c. Attach the outer door slabs to the door frame.
 - d. Install the center door slabs.
 - e. Make sure all doors are level and plumb.
30. *If applicable:* If the booth has center divider curtains, install the track and brackets.

NOTE

Do not install the curtain during this step.

31. Install the operator interface terminal.
32. Install miscellaneous electrical devices:
 - Temperature sensor
 - Air-sensing tube
 - *If applicable:* Damper actuators
 - Air solenoid valve
 - Economy valve
 - Air-proving switch
 - Puff switch
33. Secure the wall panels to the floor profile.
34. Complete the installation of intake and exhaust stacks.

NOTE

The roofing contractor must cut the openings in the roof and seal around the ductwork.

35. Caulk the booth.
Do not caulk between fixed roof panels and explosion-relief panels. Caulking the explosion-relief panels will inhibit operation of the explosion-relief system.
36. Use a vacuum to clean out the pit, tunnels, intake plenum, and air heater (intake and exhaust side) of any debris.
37. *If applicable:* Install the frontal and center divider curtains on their tracks.
38. Install booth filters:
 - a. Install the intake filters into the filter racks.
 - b. Install the filter rack in the ceiling of the booth.
 - c. Install the GFS Wave[®] filter media and balancing pans in the pit.
39. Allow contractors to perform electrical hookup, plumbing/piping, and roof work, as needed.

Perform commissioning and startup

Prerequisites:

- The booth must be fully assembled and caulked.
- Intake filters and the exhaust filter media must already be installed.
- The air heater must have been vacuumed or swept out, and the air heater filters must already be installed.
- An electrician must have completed the electrical hookup.

NOTE

A trained GFS Distributor usually performs booth startup. The person who performs booth startup is responsible for completing the Final Commissioning Document and returning a signed copy to GFS.

Reference: Refer to the Final Commissioning Document. (For information on locating the Final Commissioning Document, see “Gathering required documentation” (page 13).)